CHAPTER 19

RADAR GUIDANCE OF MISSILES*

Alex Ivanov
Missile Systems Division
Raytheon Company

19.1 INTRODUCTION

Radar guided missiles represent one of the most widely used applications of the radar art, yet one about which much less has been published in the open literature than about other, more “conventional” radars. There is no nonmilitary use of this part of radar technology, and much of the detailed data is still classified. However, drawing solely on the unclassified published data permits at least a tutorial overview of radar guidance to be presented in this chapter.

Guided missiles can be characterized in several ways,¹⁻⁴ based on their mission, type of guidance, sensing wavelength, source of guidance energy, etc. The discussion here will narrow down to the particular radar homing types which form the vast majority of operational systems.

Based on their use, missile systems can be categorized as surface-to-surface, air-to-surface, surface-to-air, and air-to-air. The types of guidance are inertial, map-following, command, beam-riding, and homing. Types other than inertial can use the broadest range of the electromagnetic spectrum, from radio frequencies (RF) through infrared (IR) to the visible spectrum and beyond, to perform the guidance function.

Within these general categories, the surface-to-surface types [especially the intercontinental ballistic missile (ICBM) and the shorter-range ballistic] are usually inertially guided and fall outside the scope of this discussion. The primary exception is the antiship missile, which uses radar guidance and may be surface- (as well as air-) launched.^{4,5} The main users of radar guidance are the air defense systems—surface-to-air or air-to-air. These also can employ IR or laser radars, but we shall restrict our discussion to the microwave radar category. Air-to-surface systems for use against ships, armored vehicles, or hard fixed targets

*The author is indebted to the many colleagues at Raytheon who reviewed various sections of this chapter and especially to David Barthuli, John Curley, and Al Williams for their many valuable comments and suggestions.

such as bridges, can use the visible spectrum (TV), IR, laser, or radar. Only the last-named category will be discussed.

Whether they are used against airborne or surface targets, guided missiles are intended to achieve a much higher accuracy than conventional artillery, which relies on open-loop prediction (even when optical or radar target tracking is employed for fire control). To achieve the required accuracy, a guidance system utilizes automatic closed-loop control by continuously sensing errors in the missile-to-target intercept geometry and translating them into corrective missile maneuvers designed to reduce miss distance to zero, although in practice a finite miss distance usually results.

Radar has been extensively used for command, beam-riding, and homing guidance. The simplest form of guidance is the beam rider. The target is tracked by a tracking radar (or, in early systems, by an operator using an optical sight with a radar slaved to it) which keeps the beam always pointed at the target. The missile itself does not perceive the target but detects its own position relative to the tracking beam. By keeping itself centered in the beam, it attempts, like the radar beam it rides, to pass through the target. In command guidance the target and the missile are tracked by separate radars (or by separate beams of a phased array radar). The missile itself does not perceive the target. Measured target and missile states are fed to a computer which calculates the missile trajectory required for intercept and develops the guidance commands which are continuously transmitted to the missile. In both these systems accuracy is inversely proportional to range from the radar, since a fixed angular error at the radar becomes an increasing linear error at increasing ranges.

Homing provides the highest accuracy at the cost of complexity of the missile-borne hardware. Whereas the beam rider and command systems require only a single receiver in the missile, to sense the beam or receive commands, the homing system perceives the target with its own radar (called the *seeker*), extracts tracking data from the received signal, and computes its own steering commands. As it closes on the target, a fixed angular error at the missile results in a decreasing linear error, providing the higher accuracy characteristic of homing guidance.

Homing systems can be further categorized on the basis of the source of the sensed radar energy into passive, semiactive, and active. Passive homing uses energy originating from the target (i.e., jamming or radar transmissions). An active homing system is a self-contained radar which transmits its own radar energy at the target and tracks the target-reflected energy. The semiactive system includes an external radar which illuminates the target while the missile receives and tracks the target-reflected energy to extract guidance information.

The waveforms used vary from noncoherent pulse (used in some early systems) to continuous wave (CW) and coherent pulse doppler (PD). The most widely used operational systems have, over the years, employed CW semiactive homing. Since the active systems differ only by virtue of the presence of the illuminator-transmitter on board the missile, a discussion of the semiactive system can be easily extended to cover the active type as well. Similarly, passive homing can be considered a subset of the semiactive.

Because of antenna size constraints, operating frequencies have generally been in the C, X, or K_u bands. The increased availability of components at higher frequencies has permitted operation at K_a and millimeter-wave frequencies in later-generation systems.

The nature of missile systems and the environment in which they are developed result in evolutionary changes rather than revolutionary innovations. Thus to understand today's systems we must understand how they became what they

are. This chapter will, therefore, begin with a discussion of the CW semiactive system and trace the evolution of the CW seeker through several generations. Once these concepts have been explained, they will be extended to the active and passive systems. Functional operations (i.e., acquisition, tracking) and characteristics of subsystems will then be discussed.

19.2 OVERVIEW OF SEMIACTIVE CW SYSTEMS⁶

The basic semiactive system is conceptually illustrated in Fig. 19.1. The illuminator maintains the target within its radar beam throughout the engagement. The missile receives the target-reflected illumination in its front antenna and a sample of the directly received illumination (often through sidelobes of the illuminator antenna) in its rearward-looking reference (rear) antenna. The front and rear signals are coherently detected against each other, resulting in a spectrum which contains the doppler-shifted target signal at a frequency roughly proportional to closing velocity. A narrowband frequency tracker searches the spectrum, locks onto the target return, and extracts guidance information from it. The use of CW provides the capability of discriminating against clutter on the basis of doppler frequency and thus allows low-altitude operation.

Doppler Frequency Relationships. The geometry for the doppler frequency relationships in a general semiactive case is shown in Fig. 19.2. The doppler shift is a function of the transmitted frequency f_0 and radial velocity V_R [the component of velocity along the line of sight (LOS) from the source to the observer—either a receiver or a reflector].

$$f_{\text{dop}} = (f_0/c)V_R$$

where c = velocity of light.

In the geometry of Fig. 19.2, the *rear*, or reference, doppler is a function of the radial velocity of the missile with respect to the illuminator. The *front*, or target, doppler frequency, depends on the radial velocities of the illuminator, missile, and target. The resulting spectrum, when the front signal is coherently detected

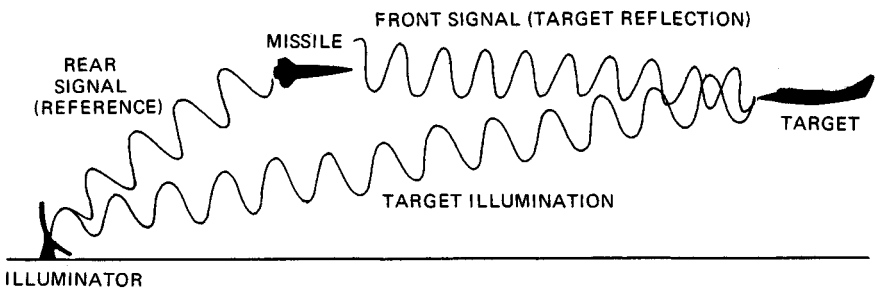

FIG. 19.1 Semiactive homing employs an illuminator to illuminate the target and provide a reference to the missile, which compares the reference with the reflected-target illumination to extract guidance information.

(mixed) against the rear, is the difference of the two.

$$f_{\text{rear}} = -\frac{f_0}{c}V_M \cos \theta + \frac{f_0}{c}V_I \cos A$$

$$f_{\text{front}} = \frac{f_0}{c}(V_T \cos \phi + V_T \cos \beta + V_M \cos \alpha + V_I \cos B)$$

$$f_d = f_{\text{front}} - f_{\text{rear}}$$

$$= \frac{f_0}{c}(V_M \cos \theta + V_M \cos \alpha + V_T \cos \phi + V_T \cos \beta + V_I \cos B - V_I \cos A)$$

For a stationary illuminator $V_I = 0$. Closing velocity is $V_C = V_M \cos \alpha + V_T \cos \beta$. For the head-on case, all angles become zero and $V_C = V_M + V_T$, with the result that $f_d = (f_0/c)2V_C$. The constant of proportionality f_0/c at X band (approximately 10 GHz) is 10 Hz/(ft/s), and hence the rule of thumb is that target doppler is 20 Hz for each foot per second of closing velocity at X band. Scaling is a convenient way to handle other frequency bands. Where more exact doppler frequencies must be known, the exact transmitted frequency f_0 should be used.

It is important to note that, in addition to the target, there exist large interfering signals within the spectrum of interest: clutter and feedthrough (spillover or leakage of the rear signal into the front receiver through backlobes of the front antenna). Because the frequency of the feedthrough is the same as the rear signal, for a system in which the front and rear signals are mixed directly (baseband conversion), feedthrough would occur at dc (zero frequency), with the approaching and receding spectra folded around it. As will be shown later, it is usually desirable to unfold the spectrum, to separate the approach and recede portions, so that feedthrough will occur at some arbitrary offset frequency. Figure 19.3 illustrates the latter case.

The clutter doppler can be calculated by using the same equations used for the target. Let the reflecting clutter patch be the target, with a velocity $V_T = 0$. Use the appropriate angles which relate the missile velocity vector to the missile-to-clutter patch LOS. Not only main-lobe but also sidelobe clutter must be considered.

The spectrum of Fig. 19.3a shows the case of a ground-to-air missile. For small look angles (α and θ in Fig. 19.2), the main-lobe clutter (MLC) occurs at a frequency corresponding to a velocity of approximately $2V_M$. Sidelobe clutter extends all the way from $2V_M$ to zero-doppler velocity (feedthrough) as the angle between the missile velocity vector and the reflecting clutter patch varies from 0° (head on) to 180° (backlobe clutter).

The air-to-air case of Fig. 19.3b differs in that the clutter spectrum extends below feedthrough due to the airborne illuminator's backlobe, which can produce a return from a clutter patch behind the aircraft, i.e., an angle of 180° with respect to the illuminator velocity vector.

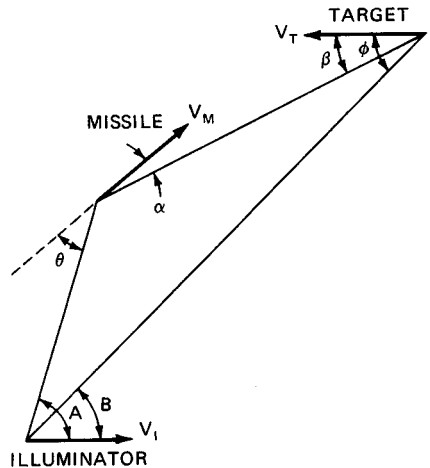

FIG. 19.2 Semiactive geometry. The radial velocity components of the three system elements contribute to the doppler shift of the received signal.

It should also be clarified what is meant by *approaching* and *receding* targets within the missile doppler spectrum. A target approaching the missile will yield a signal at a frequency above that of MLC (which corresponds to missile velocity). For the X-band case, let $V_M = 2000$ ft/s and $V_T = 500$ ft/s in level flight. MLC will then be at roughly 40 kHz and the target at 50 kHz. If the target were flying away from the missile at the same 500 ft/s velocity, its doppler frequency would be 30 kHz, or 10 kHz below MLC. However, the missile is still closing on this target at 1500 ft/s; so it is in the *approach* part of the spectrum, above feedthrough, even though it is an outbound, or receding, target. (Note that if the outbound target were faster than the missile, its doppler would be below feedthrough, but of course the missile would never catch up with it. Thus, it is a

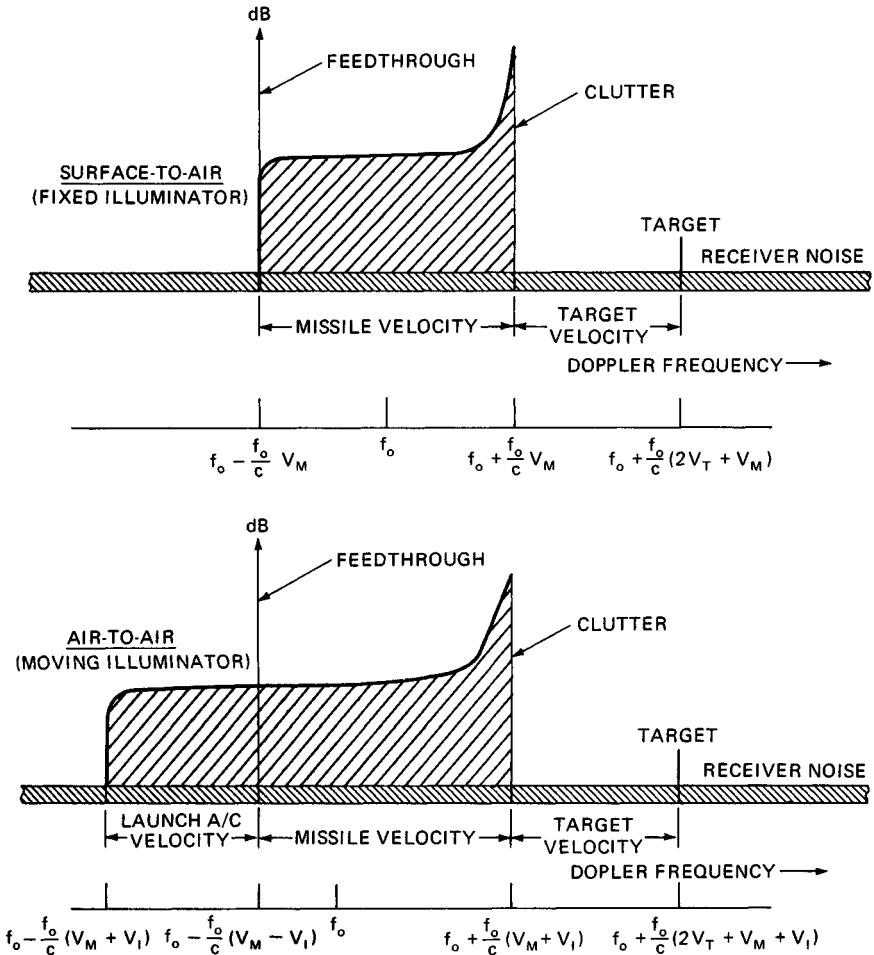

FIG. 19.3 Signal spectra for semiactive homing indicate the clutter and feedthrough (spillover) with which the target signal must compete. Both fixed and moving illuminator cases are shown. The frequencies shown are for maximum clutter extent; i.e., all angles shown in Fig. 19.2 are zero and all velocity vectors colinear.

meaningless case.) This is different for a ground-based radar, where the outbound target is in the *receding* part of the spectrum, below feedthrough. The significance of the above discussion is that while approaching targets are in a clutter-free region of the spectrum, the receding target lies in the sidelobe clutter and must compete directly with it: if the clutter in the detection cell exceeds the target, the target cannot be detected. This is of primary concern in look-down tail-chase air-to-air engagements.

One additional important factor must be noted. Although the target signal can be discriminated from the feedthrough and clutter on the basis of frequency (except for the receding target in sidelobe clutter), this is only true for spectrally pure signals. Noise on the transmitted signal and on any conversion oscillators within the missile will be spread throughout the doppler spectrum by the feedthrough and clutter and mask the target signal if the noise is not adequately controlled. Noise reduction is thus one of the key technologies required for good radar seeker performance.

Clutter and Feedthrough Considerations.^{2,5,7} The presence of clutter and feedthrough is one of the primary limitations on the performance achievable in a seeker and has been one of the main design drivers in the evolution of radar guided missiles. There are three main problems which must be addressed in connection with these large interfering signals. The first is the need to prevent lock on the clutter signal and its harmonics. Clutter in some geometries may be spectrally very narrow, resembling a target signal. Preventing lock is generally accomplished by limiting the portion of the doppler spectrum which is searched during the acquisition process, to exclude the clutter frequency. However, because clutter varies in frequency during missile flight, avoiding it can be a relatively complex problem, especially for slow-radial-velocity targets (small frequency separation from clutter). Feedthrough, on the other hand, is fixed in frequency and can thus be significantly attenuated with fixed filters and be easily avoided during search.

The second problem is often termed the *subclutter visibility* (SCV) or *subfeedthrough visibility* (SFV) problem. In essence, this refers to the maximum ratio of clutter (or feedthrough) to signal with which the system can operate. In its simplest form, this can be related to the dynamic range of the seeker receiver (i.e., its range of linear operation). One must consider not only possible suppression of the target signal by the clutter or feedthrough but also potential cross-modulation or intermodulation effects. As will be shown, gain normalization (automatic gain control, or AGC) is a key concern in achieving the required SCV.

The third problem is also related to SCV (and SFV) and is, as noted earlier, concerned with the spectral purity of the transmitter and the local oscillator. The spectrum of Fig. 19.3 will be broadened by noise, so that noise sidebands of feedthrough and clutter will appear at the target doppler frequency. In view of the magnitude of feedthrough and clutter, very low noise is required to prevent performance degradation (masking of the target). Maximum feedthrough levels can typically range from 80 to 100 dB above the target signal, while main-lobe clutter can be 40 to 80 dB greater than the target. However, the frequency separation between target and clutter is much smaller than between target and feedthrough; so, depending on the specific design and conditions, clutter may establish the more stringent noise requirement. Also, the effects of feedthrough noise can be reduced through cancellation in the missile receiver (see Sec. 19.4). Since amplitude-modulation (AM) noise in sources is generally well below frequency-modulation (FM) noise (20 dB is typical), the noise reduction techniques concentrate on FM noise.

Guidance Fundamentals.⁷⁻¹² A detailed discussion of guidance is beyond the scope of this chapter. However, to understand the effect that the radar seeker's ability to measure the target's radar observables has on the performance of the missile (miss distance), a brief overview of guidance principles is presented here.

Virtually all homing systems employ some form of proportional navigation (PN), although modern control theory (such as Kalman filtering) has been used extensively to optimize performance of later-generation systems. The important fact to note is that PN can be accomplished with angle-only measurements and can thus become a fallback mode even if range or doppler (range rate) information—required for advanced guidance techniques—is unobtainable.

Proportional navigation is based on the fact that if two objects are closing on each other, they will collide if the LOS does not rotate in inertial space, as illustrated in Fig. 19.4. Any rotation of the LOS (i.e., an LOS rate) is indicative of a deviation from the collision course which must be corrected by a missile maneuver. In PN, the rate of rotation of the LOS is measured, and a lateral acceleration of the missile is commanded according to the equation

$$n_L = N' V_c \dot{\lambda}$$

where n_L = lateral acceleration

N' = effective navigation ratio (constant, selected as discussed below)

V_c = closing velocity

$\dot{\lambda}$ = rate of change of the line of sight

The lateral acceleration ideally should be normal to the LOS; in practice the deflection of the missile control surfaces will result in acceleration normal to the missile velocity vector. The closing velocity can be estimated or, in the case of a doppler radar, measured (the target doppler is an approximate measure of V_c , as noted above). The LOS rate $\dot{\lambda}$ is measured by the seeker—this is the seeker's primary function. The value of N' is chosen to optimize performance in the face of initial errors or disturbances which would increase miss distance: heading error, target maneuver, system biases, and noise. For example, increasing values of N' cause early correction of collision course errors, reserving the missile's maneuver capability near intercept for countering target maneuvers and noise. Too high a value of N' , however, results in too great a sensitivity to noise inputs, especially glint, which increases with decreasing range. In practice, N' values in the range of 3 to 5 are normally chosen.

The missile does not respond instantaneously to an LOS rate; rather, a finite response time, made up of several components, governs the process. This equivalent time constant, referred to as the guidance time constant τ_g , is a key parameter affecting miss distance.

Several time lags in series combine to produce τ_g . These are the track-loop time constant, the noise-filter time constant, and the autopilot-airframe response time. The antenna track-loop time constant can be eliminated as a contributor in certain configurations (LOS or LOS rate reconstruction¹²). The airframe aerodynamic response will vary with missile speed and altitude, and the autopilot must compensate for this variation. The final value of τ_g is a compromise between the rapid desired speed of response to counter target maneuvers and a long desired smoothing time to minimize glint. Moreover, the variations in τ_g brought about by *parasitic feedback* effects, such as radome aberration and imperfect antenna stabilization, must be controlled to avoid guidance loop instability.

A practical rule of thumb for a properly designed system is that a homing time

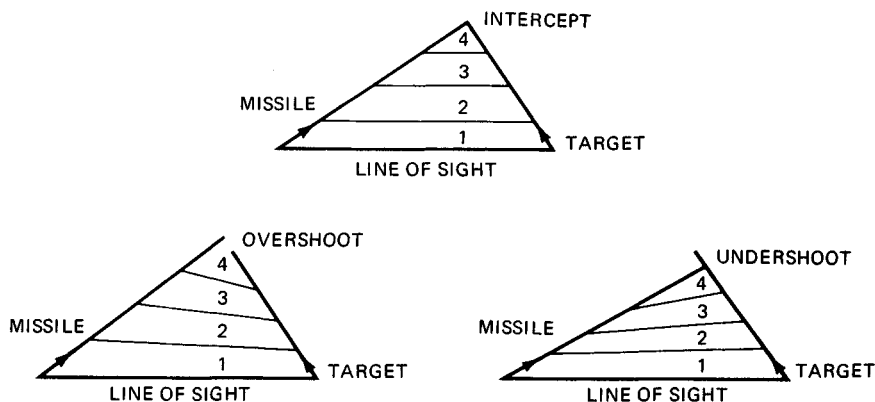

FIG. 19.4 Line-of-sight (LOS) motion of intercept. The line-of-sight rate is constant when missile and target are on an intercept (collision) trajectory.

of $10 \tau_g$ will reduce miss distance to the asymptotically achievable value. This will therefore establish minimum range capability as well as set the requirement on the terminal guidance mode of a multimode missile.

The seeker's primary function is to generate an estimate of the inertial LOS rate. To accomplish this, it must track the target in angle and stabilize the antenna LOS against missile body motions, which could be erroneously interpreted as target motions. It is the accuracy of the resulting LOS rate estimate that will determine how well the missile performs.

The fundamental limit on achievable accuracy is the target's own angle noise (glint, scintillation, and depolarization). Other noise contributors must be minimized by proper design (i.e., maximize signal-to-noise ratio to minimize range-dependent noise, reduce the range-independent noise—servo and other instrumentation noise). Also, the correct angle measurement scale factor must be maintained over the full range of signal levels and over all look angles.

Finally, the effect of the radome must be considered. Because of aerodynamic considerations, the radome enclosing the gimballed antenna will be pointed rather than a hemisphere. Thus, at different gimbal (look) angles the radar signal will pass through a different portion of the radome, and the apparent LOS to the target will change with gimbal angle because of refraction (aberration). This results from different path lengths through the dielectric material (different curvature) as well as local differences in thickness or dielectric constant. A constant error would present no difficulty, since the tracking and guidance loops are driving the boresight error (LOS rate) to zero. It is the variations of the radome error with gimbal angle—radome error slope—which cause the problem by creating a feedback path.

Since the missile responds to a target LOS rate by maneuvering, the missile body orientation with respect to the observed LOS will change as a result of the maneuver. Thus the space-stabilized antenna, while maintaining track of the target, will move with respect to the radome, and the resulting change in the refraction angle will cause an apparent additional LOS rate, closing the feedback loop. The feedback can be either regenerative or degenerative, depending on the sign of the radome error slope (the direction of the radome error).

This phenomenon must be viewed in the context of the closed antenna tracking loop. Since for a constant LOS rate the residual boresight error is a constant, any radome error which tends to increase the apparent boresight error constitutes regenerative feedback. A radome error which makes the boresight error smaller is degenerative. To a first order, positive slopes (degenerative feedback) lower the guidance gain and lengthen the guidance time constant, making for a more sluggish response, while negative slopes (regenerative feedback) raise the guidance gain and shorten the guidance time constant to the point where missile instability could occur. The guidance design must avoid such an instability.

Target Illumination.^{6,13} Target illumination for a CW semiactive missile system can be provided by a CW tracking radar, a CW transmitter slaved to another tracking radar, or a pulse or pulse doppler tracking radar at another frequency with the CW illumination injected into the antenna system from a separate CW transmitter.

The most capable of these configurations is the CW tracking illuminator. It is generally a two-dish radar because sufficient receiver-transmitter isolation cannot usually be achieved in a single-dish system. The CW tracking illuminator, since it uses the same radar signal to track the target as the missile utilizes for homing, sees essentially the same view of the target environment and can track targets at the same low altitudes as the missile seeker. The receiver portion of such an illuminator is very much like the seeker described in the following sections. The main differences stem from the much higher feedthrough levels in which the illuminator receiver operates and from the previously mentioned doppler spectrum differences (i.e., outbound targets are below feedthrough).

Alternatively, the illuminator can be the transmit-only portion of a radar slaved to a tracking radar—a mechanically scanned track-while-search (TWS) radar or a phased array which simultaneously maintains multiple target tracks with its electronically steered agile beam. In the third approach, where space constraints preclude use of separate antennas, such as in a fighter aircraft, a conventional pulse or PD radar tracks the target and the CW illumination is injected into the transmission port of the antenna from a separate transmitter.

Traditionally, the illuminator must continuously illuminate the target throughout the engagement. A system is therefore limited in its simultaneous-engagement capability by the number of available illuminators. A given illuminator must remain dedicated to its assigned target until the missile has achieved intercept; only then can it be reassigned to another. One of the primary reasons for active seekers is to remove this system firepower limitation, since each missile provides its own illumination. Another approach to avoiding the one-illuminator-one-target constraint is to use sampled data and time-share one illuminator (phased array or TWS) among several missiles.

19.3 SYSTEM EVOLUTION

Radar guided missiles have evolved through several generations since the first developments began in the closing years of World War II. The threat and the available technology have evolved over the years, and the systems have followed

suit. As new requirements have been generated in response to more severe threats, new approaches using new technology have been developed. This section will attempt to trace some of these evolutionary developments.

Basic Semiactive Seeker.^{2,6,7} The block diagram of Fig. 19.5 is representative of the earliest systems developed in the late 1940s and early 1950s. The simplest implementation of a CW missile seeker, it consists of a rear receiver, a front receiver, a signal processor (speedgate), and a tracking loop to control the gimballed front antenna. The missile also contains an autopilot to guide it and stabilize the airframe, a fuze to detonate the warhead at the optimum time, and a source of electrical and (in most missiles) hydraulic power.

The purpose of the rear receiver is to provide a coherent reference for detection of the front (target) signal. The rear signal, after conversion to IF, closes the automatic frequency control (AFC) loop around the microwave local oscillator (LO) and acts as the reference for the IF coherent detector. The target signal, received in the front antenna, is heterodyned to IF and amplified in a relatively wideband amplifier (typically 1 MHz or wider). It is then converted to baseband by mixing it with the rear signal in the balanced mixer (coherent detector). The doppler signal (now at baseband, with feedthrough at dc) is amplified in the video (doppler) amplifier, which has a bandwidth equal to the total range of possible doppler frequencies. It is then mixed with the speedgate LO, which is controlled by an AFC loop to keep the desired signal centered in the narrow speedgate (sometimes called the velocity gate or doppler tracker). Typical bandwidths range from 500 Hz to 2 kHz.⁵

Target acquisition is accomplished by sweeping the frequency of the speedgate LO over the designated portion of the doppler bandwidth. In essence, this sweeps the spectrum past the narrow frequency window of the speedgate. When a signal exceeds the detection threshold, the search is stopped and the signal is examined to verify that it is a coherent target rather than a false alarm due to noise. A valid target is then tracked in frequency, and guidance commands are extracted from it.

The front antenna conically scans the received beam. The resulting amplitude modulation of the received signal is recovered in the speedgate and resolved into the two orthogonal pitch and yaw gimbal axes. These pitch and yaw error signals are used to close the antenna tracking loop and to guide the missile.

The guidance error signal must be normalized (a constant scale factor of volts per degree off boresight is required) over the full dynamic range of target signal amplitudes (range, target size) in the presence of large feedthrough and clutter signals. Therefore, AGC in the receiver is necessary. Since the IF amplifier signal includes both the feedthrough and the clutter while the video amplifier includes the clutter, the specific AGC implementation must consider the degree to which these large interfering signals shall be allowed to control the gain for the target signal while preventing saturation on the interference. To maintain linear receiver operation over the large dynamic range is a major design challenge.

Unambiguous (Offset Video) Receiver. The basic receiver described above folds the spectrum around feedthrough, which occurs at dc. Although in the moving missile this does not produce an ambiguity, in the tracking illuminator the inbound targets must be distinguished from the outbound. This *unfolding* of the spectrum was initially achieved by use of a quadrature receiver (Chap. 14).

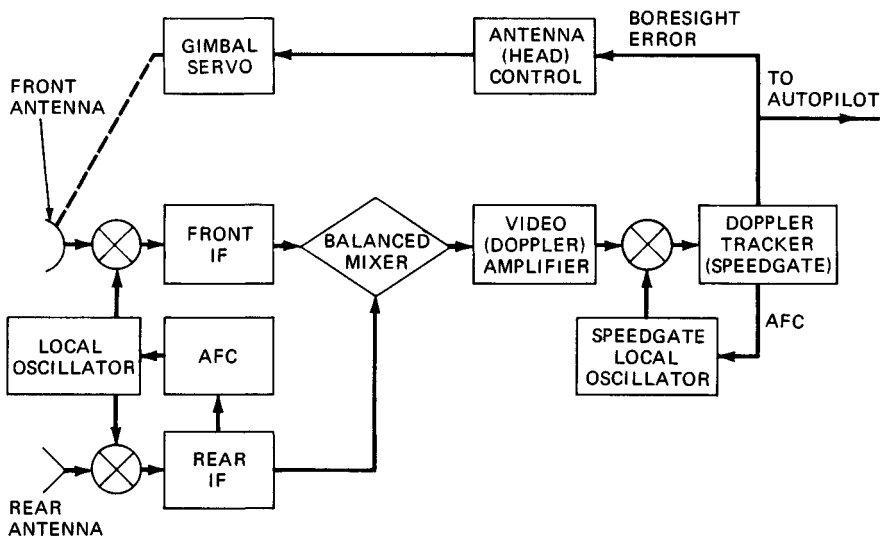

FIG. 19.5 This semiactive-seeker block diagram of a baseband conversion system is representative of the early-generation systems in which the rear (reference) and front signals are mixed directly to extract the doppler-shifted target signal.

There are two additional drawbacks to the original configuration. Folding the spectrum around feedthrough folds the receiver noise as well, resulting in a 3 dB higher noise level (hence a 3 dB loss in sensitivity).⁵ The other problem stems from the fact that main-lobe clutter is the dominant signal in the doppler spectrum. Clutter harmonics can be misclassified as targets and must therefore be avoided, thus limiting the usable range of target dopplers. For example, consider a clutter-to-signal ratio of 60 dB. A mere 0.1 percent second harmonic distortion would yield a clutter harmonic of the same magnitude as the target. If a missile velocity of 2000 ft/s is assumed (40 kHz doppler at X band), the harmonic would occur at 80 kHz, and the usable doppler spectrum, which the speedgate would be able to search, could extend no further than 80 kHz (in practice a safety margin of a few kilohertz would have to be maintained at both ends of the search region, further limiting achievable performance). This is illustrated in Fig. 19.6a.

However, by introducing a frequency offset before the coherent detector,⁵ the resulting spectrum will be as shown in Fig. 19.6b. This can be accomplished by offsetting either the signal or the reference channel. Figure 19.7 shows the offset reference configuration. Clutter harmonic distortion, noise foldover, and (for the case of the illuminator) approach-recede ambiguity are eliminated. However, feedthrough rejection now requires a complex notch filter at the relatively high offset frequency rather than a simple high-pass filter. Also, clutter still controls the gain normalization in the doppler amplifier.

For each frequency conversion, spurious higher-order mixer products must be considered and kept out of the target spectrum. As additional conversions are added, this task becomes increasingly difficult and seeker complexity grows. Ex-

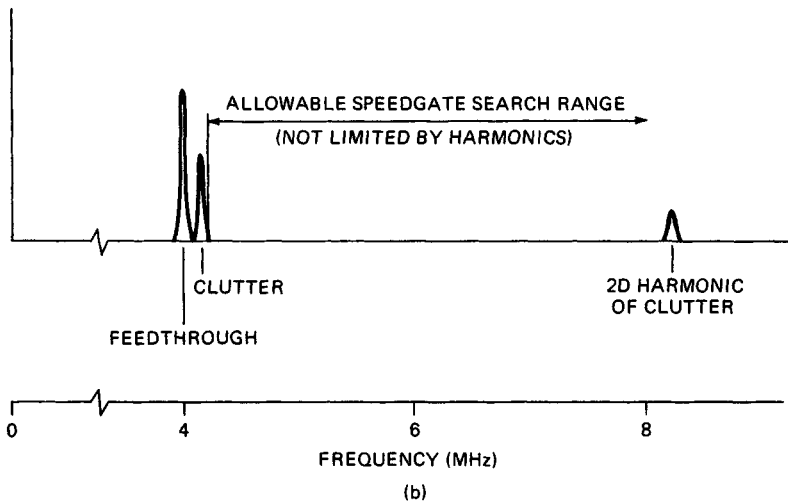
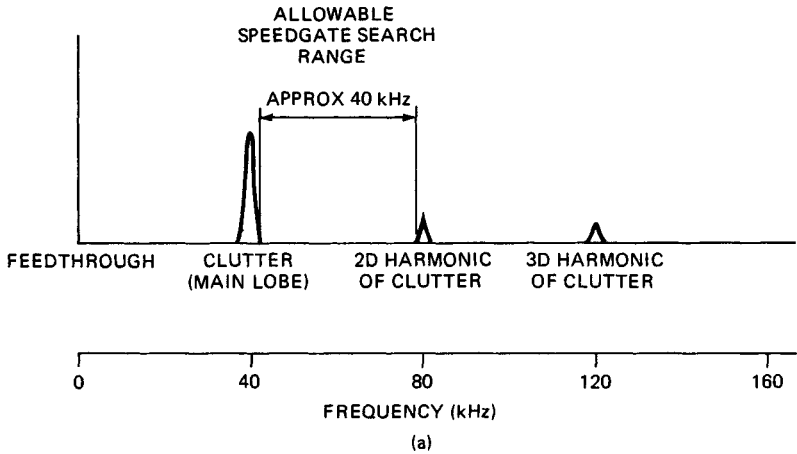

FIG. 19.6 Target spectra of the baseband (folded or ambiguous) receiver (a) and the off-set video (unambiguous) receiver (b) indicate the limitation which clutter harmonics impose on the achievable range of target velocities which can be handled.

tending the speedgate's frequency coverage to cope with faster targets and attempts to eliminate—or at least attenuate—clutter required additional conversions, which, even with the introduction of solid-state circuitry to replace vacuum tubes, resulted in prohibitive increases in size, complexity, and reduced reliability.^{2,6}

Inverse Receiver.^{2,6,14} The major breakthrough was the introduction of the *inverse receiver*, which gets its name from the fact that the bandwidth “funnel” of the conventional receiver (wide IF, narrower doppler amplifier, final narrowband speedgate) is inverted, with the final narrow banding (speedgating) placed right after the first conversion from microwave to IF. The crit-

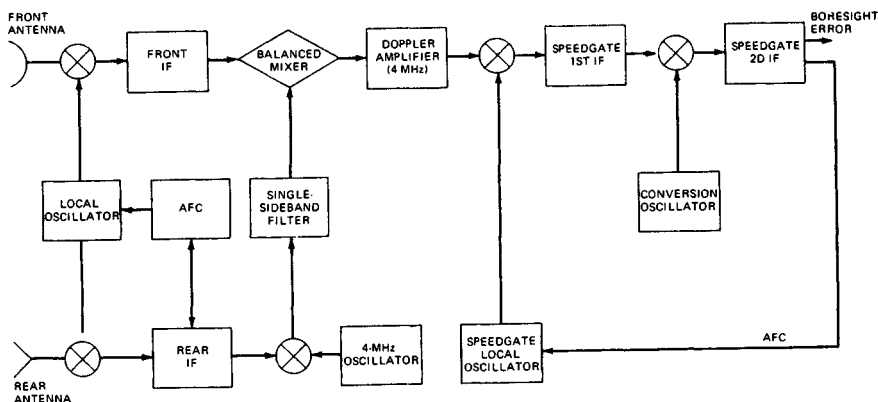

FIG. 19.7 Offset video receiver block diagram. It provides an unambiguous (unfolded) doppler spectrum by offsetting the rear reference before it is mixed with the front signal.

ical components necessary for the inverse receiver are highly selective filters at IF frequencies and low-noise tunable microwave sources.

The simplified block diagram of an inverse receiver is shown in Fig. 19.8. In the conventional receiver, the target signal must compete with feedthrough, clutter, and jamming until the final stages, with the dynamic-range requirements of the receiver and its AGC loops dictated by these large undesired signals. The inverse receiver, on the other hand, excludes them virtually at the input. The narrowband filter (usually a quartz crystal type), constituting the speedgate bandwidth, is placed in the IF after only a nominal amount of fixed preamplifier gain, sufficient to establish noise figure. One additional conversion is used in the receiver to avoid the problem of too much gain at one frequency. In the resulting two-conversion system, complexity is significantly reduced and unwanted signals

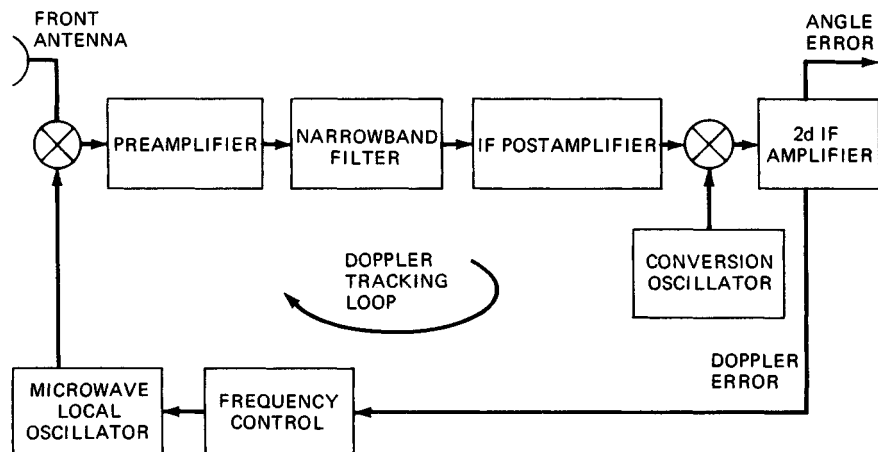

FIG. 19.8 Inverse-receiver block diagram. The narrow banding is placed very early in the receiver, inverting the bandwidth "funnel" of the conventional receiver and excluding interference from subsequent stages of the seeker.

are rejected very early in the signal path, thus reducing dynamic-range requirements and avoiding most possible sources of distortion.

The doppler tracking loop is closed through the microwave LO, which must, therefore, be tunable over the doppler frequency range of interest. This LO essentially fulfills the role of the speedgate LO in the conventional receiver of Fig. 19.5. The inverse receiver can be thought of as a double-conversion speedgate with the speedgate AFC loop closed around the microwave LO and the input to the speedgate being the microwave output of the seeker front antenna.

The IF spectrum at the mixer output will have the same form as Fig. 19.3. Sweeping the LO moves the spectrum past the narrowband filter to accomplish acquisition as in the conventional speedgate. Doppler tracking is similarly accomplished by controlling the LO frequency to keep the target in the narrow filter. The angle error signals required for guidance are extracted after the second IF amplifier. A single AGC loop (not shown), required to cope with only the target signal variations, is used to normalize the angle error signals.

Angle Tracking: Conical Scan to Monopulse. This subsection assumes that the reader is familiar with the conical-scan and monopulse angle-tracking concepts described in Chap. 18.

Conical scan requires only a single channel and extracts the angle information which is contained in the amplitude and phase of the scan amplitude modulation by simple envelope detection. Conventional monopulse normally requires three complete channels, which must track in gain and phase to maintain the proper relationship between the sum and difference channel signals (the angle information is contained in the difference/sum ratio).¹⁵ The complexity of monopulse, however, provides well-known performance advantages over conical scan.

Conical-scan processing requires that both the amplitude and the phase of the AM be preserved (at least one cycle of the scan is needed to make an angle measurement). The AGC which is required for gain normalization must therefore be slow enough not only to prevent it from following the scan AM envelope but to avoid any phase shift of the envelope¹⁵ (since this would cause cross coupling between channels; i.e., a pitch error would couple into the yaw plane, and vice versa). Thus any externally generated amplitude fluctuations (propeller modulation, target fading noise, or jamming) at or near the scan frequency will be detected along with the target BSE and will result in noise or false data. In particular, this makes conical-scan systems susceptible to AM jamming at the scan frequency (the *spin frequency jammer*).⁵

The monopulse system extracts the angular information instantaneously by comparing the difference and sum channel signals. The gain normalization can therefore be made instantaneous (fast or instantaneous AGC), and the external amplitude variations, since they affect sum and difference channels by the same relative amount, are never detected as erroneous guidance signals.

The early systems all used conical scan for angle tracking because of its simplicity. The limited available volume and discrete-component tube technology of the period mandated a single-channel approach despite the performance limitations of conical scan. The inverse receiver permitted the performance of monopulse to be achieved with the single-channel simplicity of conical scan.^{2,6,14}

Three identical mixers, preamplifiers and crystal filters, first process the three monopulse signals. Immediately after the narrowband filters, however, the difference channels are multiplexed with the sum channel at a moderate frequency (several kilohertz, much higher than the filter bandwidth). Interference at the multiplexing frequency is, therefore, prevented from passing through the filters. The modulated difference channels are combined with the sum signal, and the

composite signal is processed in a single channel (just as a conical-scan signal). The AGC, required for gain normalization, is made faster than the bandwidth of the filters and thus acts as an instantaneous AGC. Its dynamic range has to cope only with target signal variations. The normalized monopulse error signals are then demultiplexed and used for closing the guidance loops. Frequency (AM or FM) or time multiplexing can be employed. If the frequency multiplexing is phased so as to produce AM sidebands, the processing is identical to that of conical scan.

Pulse Doppler (PD) Operation.²⁻⁶ Semiactive systems using other than CW illumination have been employed. Some early systems employed noncoherent pulse waveforms, but they are not suitable for operation in clutter (except for very large target cross sections). Coherent PD systems, however, can approach the performance of CW.

The motivation for the use of PD in the seeker was to simplify the illuminator in air-to-air systems. For early-generation airborne radars, which employed a noncoherent pulse waveform, CW injection was the only practical solution. With the advent of coherent PD radars, an alternative way to achieve virtually CW operation without the penalty of the additional transmitter became available. This was to select a high-PRF (pulse repetition frequency), high-duty-cycle (30 to 50 percent) waveform and to use only the central line of the PD spectrum, both in the radar and in the seeker. This has sometimes been called *interrupted CW* (ICW).³

A high PRF is defined as one which is unambiguous in doppler. Thus when the receiver selects the central line, the spectrum is identical to the CW case. The radar receiver must be protected during transmission (duplexing and/or gating). In addition, the receiver may or may not use a range gate. If only the central-line power of the PD spectrum is used (no range gate), the resulting loss must be accepted. Use of a range gate matched to the pulse avoids this loss. In either case, the rest of the receiver and signal processing is the same as for a CW system.

The seeker implementation follows this same pattern. However, range gating in the seeker is generally not used with a high-duty-cycle system. The loss resulting from use of only the central line is essentially the duty cycle d_r . For a peak transmitted power P_t , the average power in the central line is $P_t(d_r)^2$, compared with the average power of the transmitted waveform of $P_t(d_r)$.

A low duty cycle (less than 10 percent) can also be used, but for this case the central-line power loss becomes prohibitive. Low-duty-cycle systems, therefore, must use range gating to optimize performance. In addition to retaining doppler resolution capability the range-gated system provides range resolution.

Active Seekers.^{4,16} Active seekers can provide increased firepower as well as fire-and-forget (or launch-and-leave) operation. Thus, they have found application in both the air defense and the surface-target attack roles.

An active seeker is functionally the same as a semiactive seeker, with the exception that it carries along its own illuminator. Besides adding the transmitter, the other main difference in the active seeker configuration is elimination of the rear receiver, with the reference generated by offsetting the transmitter excitation (or drive) signal, as shown in Fig. 19.9.

Active seekers, since they use a single antenna both to transmit and to receive, cannot use CW because of the very limited isolation achievable. Noncoherent pulse or coherent PD waveforms have been employed, and either the central-line processing or the range-gated approach can be used for coherent operation.

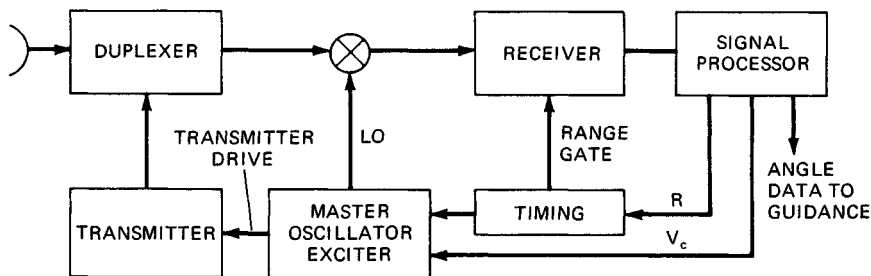

FIG. 19.9 The active seeker block diagram differs from the semiactive in that target illumination is provided by a self-contained transmitter.

Surface Targets.^{4,5,17} Noncoherent pulse waveforms have been widely used in active seekers designed for attacking large-cross-section surface targets. For example, in antiship applications the slow target speed prevents effective doppler resolution from clutter, but the large target reflectivity provides an effective discriminant since the target return exceeds sea clutter by several orders of magnitude (large signal-to-clutter ratio). Even in antitank applications, such *contrast* discrimination of the target can be achieved if the size of the competing clutter patch can be reduced by the use of narrow-beamwidth antennas and narrow range gates. These noncoherent systems utilize low-duty-cycle short pulses or highly coded waveforms to achieve narrow range resolution. The resolution cell is determined by the range-gate duration in the range dimension and by antenna beamwidth in the cross-range (azimuth) dimension. The resulting surface clutter return, even for rough seas and fairly severe ground reflections, will contribute much less energy than the target echo even when the target fills only a small portion of the resolution cell. Thus the angle information derived will be primarily from the target, because of its large contrast with respect to the clutter background, and accurate homing can be achieved. It should be noted that radar cross sections of ships can be several thousand square meters, while those of tanks typically range from 25 to 125 m².¹⁷

For severe clutter and reduced target cross sections, coherent processing may be required. Although stationary or very slow-moving targets cannot be discriminated from clutter on the basis of doppler frequency, use of *doppler beam sharpening* or synthetic aperture techniques can reduce the effective size of the resolution cell and hence increase the signal-to-clutter ratio in the cell containing the target.¹⁸ Angle tracking can thus take place to provide the required data for guidance.

Air Targets.^{4,16} Although some early systems were designed to use noncoherent pulse waveforms, they were not suitable for low-altitude (high-clutter) operation against small-cross-section aircraft targets. Therefore, the typical air defense active missile employs some form of PD transmission and coherent processing to resolve and track the target in doppler (velocity) and sometimes also in range.

The active PD seeker can be thought of as a miniature airborne fire control radar. The waveform selection tradeoffs, especially the clutter-waveform interactions, are the same in the active seeker as in the airborne intercept (AI) radar. The unique problems of clutter ambiguities, eclipsing, range determination, etc., are the same as described in Chap. 17 and will not be repeated here. A key point is that the active seeker is a monostatic radar, whereas the semiactive system is bistatic. The doppler frequency relationships can be simply derived from the ge-

ometry of Fig. 19.2 by colocating the illuminator and missile and making the illuminator and missile velocity vectors coincident. The doppler spectrum will be like that of Fig. 19.3b.

Although it is highly desirable to select a high PRF (HPRF), which is unambiguous in doppler, it may be necessary in some system applications to use a medium PRF (MPRF) and operate with both range and velocity ambiguities (which must be resolved).¹⁹ The tail-chase look-down air-to-air scenario is a key example. Since the target return must directly compete with the sidelobe clutter in the doppler resolution cell, it may be necessary to reduce the absolute amount of clutter contained in the cell. A positive signal-to-clutter ratio (S/C) is necessary to permit target visibility. One way to achieve this is to range-gate and thus reduce the size of the clutter patches, the return from which is accepted in the receiver. Reducing the PRF reduces the number of intervening range-ambiguous clutter patches which fold into the target doppler cell, further improving S/C .

To maximize range performance (not clutter-limited) average transmitter power must be the maximum practically achievable. Within the constraints of a tactical missile—small size, limited weight—this will tend to drive the design to higher-duty-cycle lower-peak-power systems. This is quite compatible with HPRF, where high-duty-cycle central-line processing has generally been used. If clutter is the limiting factor rather than receiver thermal noise, lower average power is acceptable—consistent with MPRF. The difficulty arises if the same system must achieve both long-range (noise-limited, approaching target) and tail-chase (clutter-limited) performance. Transmitter hardware constraints make it difficult to vary the waveform at will over a wide range of PRF and pulse width. Thus if an MPRF system is employed, the tendency will be toward long pulses (to keep average power high without increasing peak power). Therefore, to achieve good range resolution may require some form of pulse compression.

System Implementation. Active seekers have used both conical scan and monopulse angle tracking, and the receivers have evolved from the conventional to the inverse configuration, just as with the semiactive.

Because of the limitation on achievable antenna size as well as transmitter power, the range performance of an active seeker will be considerably less than for a comparable size of semiactive seeker operating with a high-power large-antenna illuminator.⁵ Thus active systems are used in short-range homing-all-the-way applications or as the terminal guidance mode of a multimode long-range system. For example, a midcourse mode employing inertial or command guidance can be used to bring the missile within the terminal guidance range (typically the last 10 guidance time constants or a few kilometers from intercept). The target coordinates in angle (antenna pointing) and range and/or velocity (doppler), provided by prelaunch data or by command updates during flight, initialize the seeker. The target uncertainty is searched by the seeker, and when the target is acquired, the missile transitions into the terminal phase of flight. Seeker operation then proceeds as for the semiactive case until target intercept.

Passive Seekers. Three passive operating modes have been employed for missile guidance: antiradiation homing (ARH), home-on-jam (HOJ), and radiometric. ARH operation is used in missiles for attacking hostile radars, usually in an air-to-surface application (although air-to-air and surface-to-surface systems are also potential configurations). HOJ is an essential adjunct for semiactive and active systems to counter noise jamming.⁴ The radiometric homing mode has been employed as a terminal guidance mode in millimeter-wave antitank missiles.¹⁷

*Antiradiation Homing.*²⁰ ARH systems differ from the active or semiactive air defense or the ship or ground attack systems in that they are very wideband (octave bandwidth or wider). This need for wideband operation is the main driver in seeker design. The receiver configuration is very similar to the emitter location and identification systems often called ESM (electronic support measures).²¹ However, the size and weight constraints of missile-borne hardware restrict usable approaches.

The parameters available to an ARH sensor include frequency, PRF, pulse width, angle (direction of arrival), and signal amplitude. Various combinations of these can be used to discriminate and select a specific emitter from among the multiplicity of signals present (estimates of 10^6 pulses per second have been cited as a "high-density" environment²¹). Signals must be initially sorted on the basis of frequency and then the pulse trains *deinterleaved* to select a particular emitter. Most radars will be detected primarily through their sidelobes, requiring reasonable sensitivity, but the dynamic range must be able to cope with main-lobe signals as well.

Broadband antennas can be gimballed or body-fixed. Since directional information must be determined on each received pulse, some form of monopulse antenna is required. Because the seeker may encounter any incident polarization, the antenna should have a uniform response to all senses of linear polarization.²⁰

Four types of antenna systems are possible: an amplitude monopulse with four squinted beams, a three-channel phase-amplitude monopulse using four elements or apertures, an interferometer, and the two-channel polar monopulse using a four-arm dual-mode spiral.²² The first three are conventional configurations except that each of the antenna elements is a broadband device such as a log-periodic type, conical log spiral, or cavity-backed planar spiral. The dual-mode spiral has been the preferred choice, since a single aperture generates all the direction-finding information (and thus makes full use of the limited available space), requires only two receiver channels, has excellent polarization characteristics, and is frequency-independent.²⁰

The four arms of the spiral are fed by a mode-forming network to form a sum (Σ) and a delta (Δ) mode (hence the name *dual-mode*). The directional information is contained in the relative amplitude and phase of the Σ and Δ channels. The Δ/Σ ratio represents the magnitude of the BSE (the angle off axis in a cone of rotation about the boresight), while the relative phase indicates the direction on the cone of rotation. This polar information is then converted into the more conventional pitch and yaw coordinates.²³

A variety of receiver types can be used to analyze the signal spectrum: wideband crystal video, instantaneous-frequency measurement (IFM), channelized, scanning superheterodyne, compressive (microscan), or Bragg cell (acoustooptic).^{21,24} Size and weight limitations dictate that a single-channel approach be used in a seeker. The contradictory requirements of wide instantaneous bandwidth for rapid acquisition and narrow bandwidth for high sensitivity can be achieved by using switchable bandwidths, such as shown in the typical block diagram of Fig. 19.10. This also includes a compressive receiver which is ideal for CW signals. In this approach, the local oscillator is swept rapidly (*chirped*) to impress linear FM on the signal. A matched compressive delay-line filter then compresses the signal, producing a short pulse, the time of occurrence being indicative of RF frequency.^{25,26}

Home-on-Jam.^{3,4,27} The HOJ mode is an essential part of a semiactive or active seeker. The use of wideband noise represents the earliest brute-force active jamming technique which can mask the desired target reflection. The jamming,

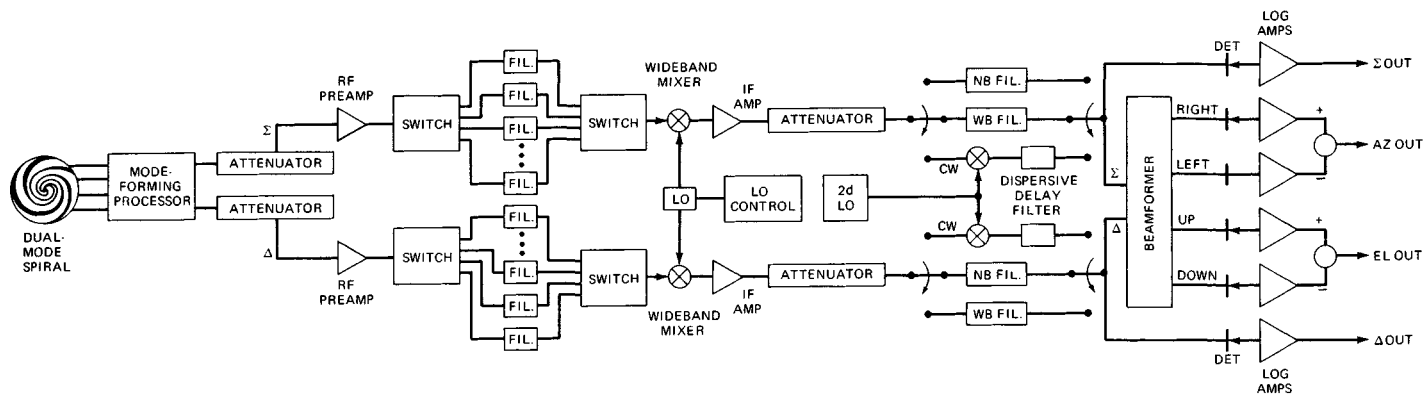

FIG. 19.10 Antiradiation homing (ARH) receiver. A typical configuration is shown, including a dual-mode spiral antenna, high first IF, switchable bandwidths, and compressive (microscan) CW processing. (From Ref. 20.)

however, is a powerful point source of radar energy which can provide more than adequate angle information for homing. All that is required is a means to allow the seeker angle track circuits to process the noise energy. When the jamming is such that tracking of the target *skin* return is not possible, the seeker switches to passive tracking of the received jamming energy. If the jammer-to-signal ratio (J/S) decreases to the point that skin track is again possible, this is given preference over HOJ. Also, provision must be made to allow switching between HOJ and skin if the jamming is intermittent. The criterion in all cases is that the mode which provides the better quality of guidance information should be given precedence.

Radiometric Homing. This mode utilizes the natural thermal radiation from targets for guidance. The very sensitive receiver detects the difference in radiation between the target and the ambient background. Use of this technique in millimeter-wave seekers against surface targets provides a terminal mode with significantly lower glint than the active or the semiactive radar mode.

Other System Configurations. Variations of the above seeker types as well as multimode combinations have been studied and in some cases implemented to take advantage of new and emerging technologies.

Sampled-Data Operation.^{2,4,6} To overcome the limitation of tying up an illuminator for the duration of a semiactive engagement, a single radar can be time-shared among several missiles. This generally implies a phased array radar, although mechanically scanned track-while-scan (TWS) radars can provide this option in some cases.

The advent of phased array radars permitted a single transmitter to illuminate many targets by sequentially stepping its agile beam from one target to the next. The illumination was no longer continuous, and the missile would thus have to operate in a sampled-data mode, extracting information during the time that its target was illuminated (dwell time) and then holding the information until the next sample. The illumination waveform could be CW during the dwell time (interrupted or keyed CW), or PD could be employed with or without pulse compression.

For sampled-data operation, the primary difference is in the doppler acquisition scheme. Since target illumination occurs only in short bursts, the use of a sweeping gate for acquisition would result in excessively long acquisition times. The doppler uncertainty region must, therefore, be examined simultaneously by a bank of contiguous doppler filters. The illumination burst must be shaped or the received signal time-gated to prevent the spreading of clutter through the target doppler spectrum owing to the pulsed nature of the transmission. Finally, sample-and-hold circuits must be added in AFC, AGC, and angle track loops.

Either the conventional or the inverse receiver can be made to operate in the sampled-data mode. Sampled data can be used all the way to intercept or as a midcourse mode for an active terminal seeker. Lower data rates are allowable in midcourse than in terminal, providing an additional degree of freedom in the system design.

Retransmission Guidance.^{13,28-31} Retransmission guidance, also known as TVM (target-via-missile or track-via-missile), was initially conceived as a simplification of missile-borne hardware, placing all the processing on the ground and making the seeker a simple repeater. In practice the repeater is limited in gain by the usual transmit/receive isolation (ring-around problem); so additional complexity must be added. At the same time, use of more complex pulse compression waveforms could be more easily accommodated by not requiring the sophisticated processing hardware to be missile-borne.

TVM is essentially a variation of semiactive homing. The target-reflected illumination is received in the missile, but instead of being processed on board it is retransmitted to the illuminating radar. Here the complex waveform is processed, guidance information extracted, and steering commands transmitted to the missile as in a command guidance system.

Multimode Systems.^{2,4,16} The early CW semiactive systems were generally designed to home all the way from launch to intercept. In later-generation, more sophisticated systems, homing generally lasts for only the last few seconds of flight (typically 10 guidance time constants). In these systems, a midcourse phase (inertial, beam rider, or command) is employed to get the missile to an appropriate point on its trajectory, where it acquires the target (using prelaunch or in-flight commanded designation data) and enters the terminal (homing) phase of its flight. This is more efficient from the standpoint of both missile trajectory and radar power. The missile can fly out to longer ranges by a commanded or inertial up-and-over trajectory, spending less time in the denser air at low altitude. The radar power needed for illumination (semiactive or active) is sized by the terminal phase of flight, a fraction of the total intercept range. Midcourse commands impose much less severe demands on radar power since this is a one-way transmission path.

Combinations of semiactive or active radar with IR or ARH modes and the trend for operation at higher frequencies offer a large number of potential multimode seeker configurations.

19.4 SYSTEM FUNCTIONAL OPERATION

There are a number of necessary functions all of which must be successfully accomplished to permit a lethal intercept of the target by a guided missile. These begin with initial target detection and decision to engage and include missile launch, proper operation of the propulsion, guidance, and control systems through the flight, and fuzing and detonation of the warhead at intercept. We shall now consider the radar functions of target acquisition and tracking which provide the intelligence for guidance. Emphasis is on semiactive or active coherent operation unless noted otherwise.

Reference-Channel Operation.^{2,5,6,32} Within the context of a coherent system, the seeker must have available as a reference a precise replica of the illuminating signal. In semiactive systems this has generally been provided by the rear (reference) receiver (although an alternative *on-board reference* approach is also possible). In active systems the reference is derived directly from the transmitter-exciter.

The reference must be spectrally pure (low-noise), and its frequency must accurately represent the illumination frequency to allow the target echo to fall within the bandwidth of the receiver. These requirements are relatively easy to meet in an active system because the same microwave source provides the reference and the transmitter exciter (drive) signal. In semiactive systems, particularly in the early-generation systems in which the transmitters were not crystal-controlled, providing a coherent reference posed a significant challenge.

The early-generation illuminator transmitters generally employed magnetrons or klystrons as power sources which, while possessing good short-term stability and low near-carrier FM noise, lacked the setability and long-term drift charac-