

22

Environmental Control

R Tricker MSc, IEng, FITE(elec), FInstM, FIQA, MIRSE
Herne European Consultancy Ltd

Contents

- 22.1 Introduction 22/3
- 22.2 Environmental comfort 22/3
 - 22.2.1 Personal comfort 22/3
 - 22.2.2 Temperature and humidity 22/3
 - 22.2.3 Parametric limits 22/3
 - 22.2.4 Visual and acoustic parameters 22/5
 - 22.2.5 Widening the environmental specification 22/6
 - 22.2.6 Machines and processes 22/10
 - 22.2.7 Safety requirements 22/11
- 22.3 Energy requirements 22/11
 - 22.3.1 Steady-state loads 22/11
 - 22.3.2 Dynamic or cyclic loads 22/11
 - 22.3.3 Intermittent heating and cooling 22/12
 - 22.3.4 Plant capacity 22/13
 - 22.3.5 Computer-aided design 22/14
 - 22.3.6 Energy consumption 22/14
- 22.4 Heating and warm-air systems 22/14
 - 22.4.1 Radiators 22/14
 - 22.4.2 Convectors 22/15
 - 22.4.3 Warm-air systems 22/15
 - 22.4.4 Storage heating 22/15
 - 22.4.5 Air conditioning 22/15
 - 22.4.6 Cooling plant 22/16
 - 22.4.7 Cooling storage 22/18
- 22.5 Control 22/18
 - 22.5.1 Controllers 22/19
 - 22.5.2 Time controls 22/21
 - 22.5.3 Building management systems 22/21
- 22.6 Energy conservation 22/22
 - 22.6.1 Systems 22/23
- 22.7 Interfaces and associated data 22/24
 - 22.7.1 Electrical loads 22/26

22.1 Introduction

The environment in which we live and work has two basic elements: the external, over which we have as yet no control, although we are beginning to understand how our activities can moderate its characteristics; and the internal which can be maintained to specified conditions to meet our needs in terms of comfort and health.

Environmental control is still frequently considered only in terms of microprocessor- and software-based control systems which traditionally maintain specified conditions of temperature, humidity (in air conditioned spaces), illuminance and noise, to achieve comfort. This narrow concept of comfort has been affected by various aspects of the current debate on environmental and 'green' issues and a growing range of health-related criteria.

Until the energy crisis of 1973–1974, the specified criteria were achieved generally without any consideration of the efficient utilisation of energy used for the purpose. Since that time energy conservation and utilisation has become a major design parameter for all buildings and building-services systems. Because buildings in the UK use approximately one-half of the overall national energy consumption, there is considerable potential for saving by suitable integrated design and selection of equipment. Such savings affect both cost and environment.

The use of electrical energy is important in all forms of environmental control, whether it be for the supply of thermal power, circulation of air and water, or control. Apart from thermal power, where the choice of fuel is often governed either by its availability or the apparent economics during the design period, electricity will virtually always be involved with the other elements. The use of particular energy sources such as oil, gas, coal, electricity, etc., may be governed by the specific application. The comparison of fuels in terms of economics and costs to the client, as distinct from the primary energy consumption for each fuel is important and needs to be considered in selecting building-services systems, but as an indirect element of environmental control.

This review of environmental comfort is generally concerned with the internal or built environment, but the effect of design and operation of buildings on the external environment should not be forgotten. Any choice of materials or fuel used in buildings and the building's services affects the overall discharge of carbon dioxide (CO₂) into the atmosphere. The CO₂ is considered to be the classic greenhouse gas, contributing to global warming, and design and operating decisions which reduce CO₂ emissions will help to minimise long-term climatic effects. If current moderate scientific opinion is accepted, global warming could have a significant effect on the internal environment during the life-time of buildings which are being erected now. It is therefore important to identify the full range of parameters which may affect comfort and health within the built environment so that interaction between external and internal conditions can be identified. Many of the suggested comfort parameters are not energy related nor are they affected by the external environment.

22.2 Environmental comfort

The indoor environment should be safe, appropriate for its purpose and pleasant to inhabit. The parameters to be considered include the thermal, acoustic and visual conditions and are now expected to encompass health and psychological factors.

22.2.1 Personal comfort

In human terms an individual senses skin temperature, not room temperature, although the latter affects the former. The body loses heat by evaporation of moisture from the skin, convection to the surrounding air and radiation to, or conduction with, cold surfaces. These mechanisms, together with the degree of activity and the type of clothing worn, tend to maintain the skin temperature constant (except for exposed extremities) over a wide range of environmental conditions. However, real comfort occurs in a much narrower range of climate, and individual requirements differ considerably both intrinsically and, again, according to the activity and clothing. The narrow zone of real comfort conditions is often classified as neutral or comfortable. This, is shown in *Figure 22.3* in terms of temperature,¹ and illustrates the degree of satisfaction for a group of people in a particular space, about the optimum neutral temperature for the group. The specified space temperature is therefore always a compromise and is only one of the criteria affecting comfort.

Other parameters can have a marked effect on the space temperature necessary to provide optimum satisfaction to the occupants. One example of these effects (*Figure 22.4*)¹ illustrates the elevation in space temperature required to compensate for increasing air movement.

Beyond the parameters which are identified above, there are now other elements which have to be considered and they are identified later, after the following sections on more traditional criteria. For many of these additional elements more research is required before their full effects on comfort can be characterised.

22.2.2 Temperature and humidity

The term 'space temperature' has been used so far to avoid confusion. Most people assume that space temperature specified in terms of the dry bulb air temperature defines levels of warmth. The previous comments indicate that this may not be valid, although temperature detectors in common use are mainly calibrated for, and measure, dry bulb air temperature. Alternative temperature indices may provide better definitions of comfort conditions or are used for design calculations: these include equivalent, effective, globe, dry resultant and environmental temperatures. Environmental temperature is used for calculation, and resultant temperature θ_{res} is considered to be a measure of comfort dependent on internal dry bulb temperature θ_{ai} , mean radiant temperature θ_r and speed of air movement u as defined in

$$\theta_{res} = [\theta_r + \theta_{ai}\sqrt{(10u)}]/[1 + \sqrt{(10u)}] \Leftarrow$$

Given that the recommended values of θ_{res} are those listed in *Table 22.1*, it is possible to adjust room temperature detectors or thermostats to a level suitable for comfort, for any mean radiant temperature and air velocity.

22.2.3 Parametric limits

Limits need to be applied to any specified comfort conditions, particularly in the case of temperature and humidity. Generally, in terms of human comfort, limits of $\pm 2^\circ\text{C}$ about a specified temperature and a relative humidity (r.h.) of $\pm 10\%$, about a mean of 50%, will be acceptable. Limits more critical than is necessary will create additional and unnecessary costs.

There may also be statutory limits which have to be applied in terms of energy conservation. In the UK since

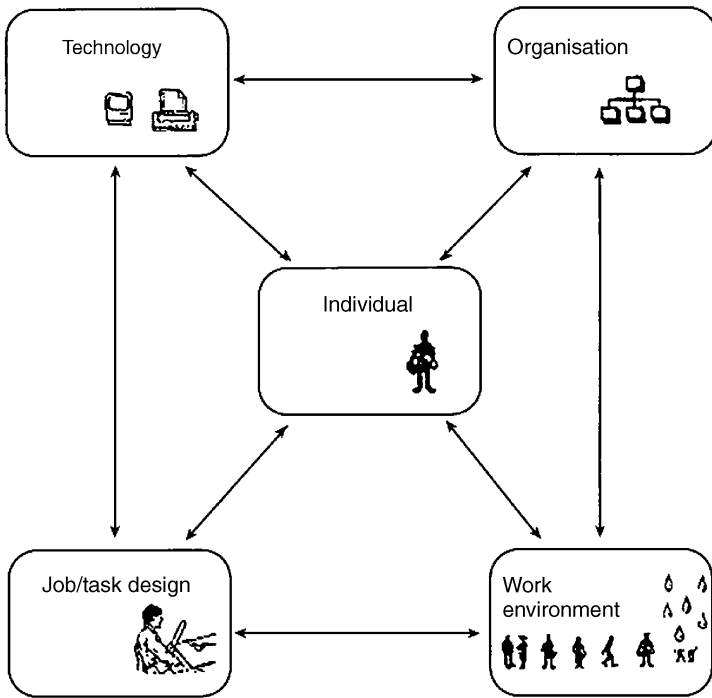

Figure 22.1 Model of the work system

1974, outside the domestic sector, space temperatures² now have an upper limit of 19°C. This is only a partial limit, because the reference covers only the heating. To complete the limit the regulation would have to specify an upper limit of 20°C for heating cycles and a lower limit of,

say, 25°C for cooling cycles. Between these two limits there would be neither heating nor cooling input.

The level of humidity in a space can have a considerable impact on comfort, but in a heated building there is a limited range of control over its value. Artificially increasing

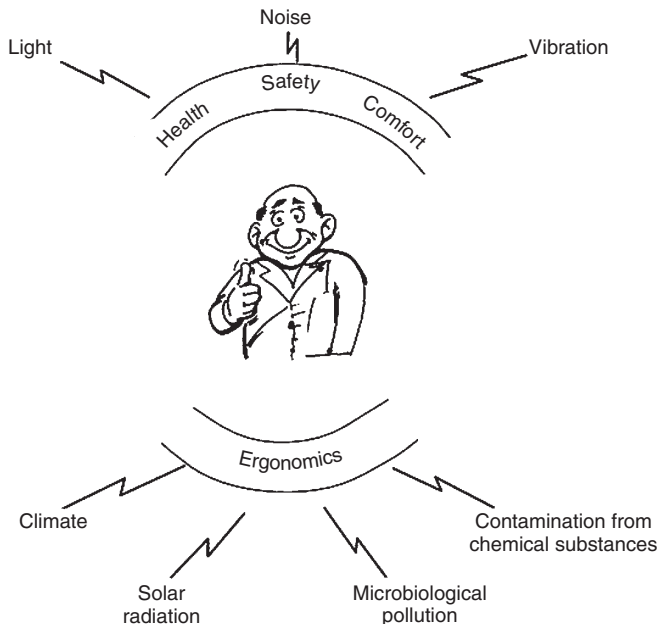

Figure 22.2 The operator/engineer's environment

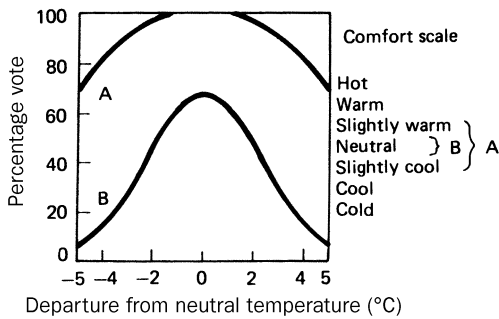

Figure 22.3 Comfort vote for personnel at around the neutral temperature for varying criteria. Curve A is for people giving any of the three central descriptions. Curve B is for the central description alone. (Courtesy of CIBSE)

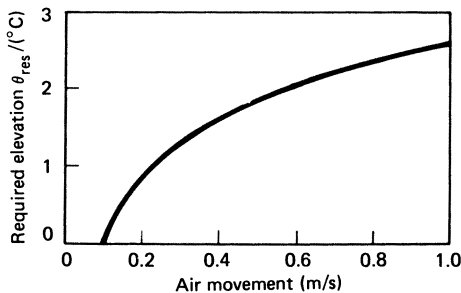

Figure 22.4 Corrections to dry resultant temperature for air movement. (Courtesy of CIBSE)

the air change rate by opening doors and windows is unlikely to be acceptable in winter and is a palliative in summer. Fortunately the band of comfort conditions in humidity terms is fairly broad for most people, and a range of 40–60% r.h. is usually acceptable and, in the UK, often occurs in practice internally. Below approximately 35% r.h., static electricity effects occur and noses and throats may be affected and above, say, 65% the effect of stickiness may be felt. Air-conditioned systems are normally designed to avoid these extremes.

22.2.4 Visual and acoustic parameters

The acoustic and visual impact on comfort conditions is extremely important. The correct level of illuminance for a particular task is important in its own right, but the overall aesthetics are a combination of the lighting level, the lighting source, the architectural finishes and their reflecting properties, and furniture and equipment. These aesthetics contribute to the comfort of the occupant.

Sound, in terms of personal comfort, is also related to the particular task. People's reaction to sound varies according to age and situation. Acoustics is both complex and subjective, and only a broad outline is included for the purpose of defining general criteria for comfort. Because the response of the ear is non-linear and less sensitive at low frequencies, it perceives equal loudness for various combinations of frequency and sound pressure levels, units of loudness being defined in phons. Sound pressure is a fluctuating air pressure sensed by the ear. The fluctuations are minute in relation to atmospheric pressure: sound pressure levels are specified in decibels. The levels are created by the sound

Table 22.1 Recommended design values for dry resultant temperature

Type of building	θ_{res} (°C)
Assembly halls, lecture halls	18
Canteens and dining rooms	20
Churches and chapels:	
$\leq 7000 \text{ m}^3$	18
$> 7000 \text{ m}^3$	19
Dining and banqueting halls	21
Factories	
Sedentary work	19
Light work	16
Heavy work	13
Flats, residences and hostels	
Living rooms	21
Bedrooms	18
Bathrooms	22
Hospitals	
Corridors	16
Offices	20
Operating theatre suite	18–21
Wards and patient areas	18
Hotels	
Bedrooms (standard)	22
Bedrooms (luxury)	24
Laboratories	20
Offices	20
Restaurants and tea-shops	18
Schools and colleges	18
Shops and showrooms	18
Swimming baths	
Changing rooms	22
Bath hall	26
Warehouses	
Working and packing spaces	16
Storage space	13

*Extracted from CIBSE Guide A1. Part of Table A1.3. Courtesy of CIBSE.

power (the power transmitted by the sound waves) which is normally considered only in reference to a sound source. Sound power levels (L) are also referred to in decibels (dB).

$$L = 10 \log_{10} (W/W_0) \text{ dB}$$

where W is the source power (in watts) and W_0 is the reference level (normally 1 pW).

Sound pressure is proportional to the square root of sound power.

A series of equal loudness curves (*Figure 22.5*)¹ is split into three sectors defined by A, B and C, which correspond to the sensitivity of the ear under varying conditions and can be measured by instruments with weighting networks corresponding to these bands. The subjective reactions for comfort in buildings are normally related to the A scale and the noise levels are quoted in dB-A. It is common to specify acceptable background noise levels for annoyance and speech intelligibility by means of NR (noise rating) or NC (noise criteria) curves, the former being most commonly used in Europe. Both sets of curves attempt to express equal human tolerances to noise across the audible frequency spectrum and are based on subjective experimental data. Normally the curves specify noise levels between 4 and 8 units below the measured dB-A values, although the relationship is not constant. *Figure 22.6* shows the NR curves and *Table 22.2* lists the recommended noise ratings for various situations.

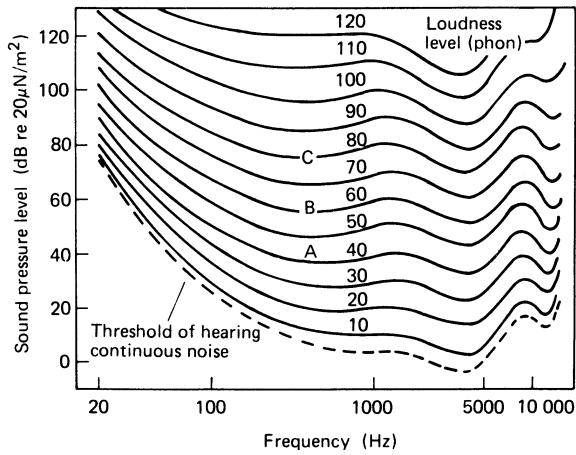

Figure 22.5 Equal-loudness-level contours. (Courtesy of CIBSE)

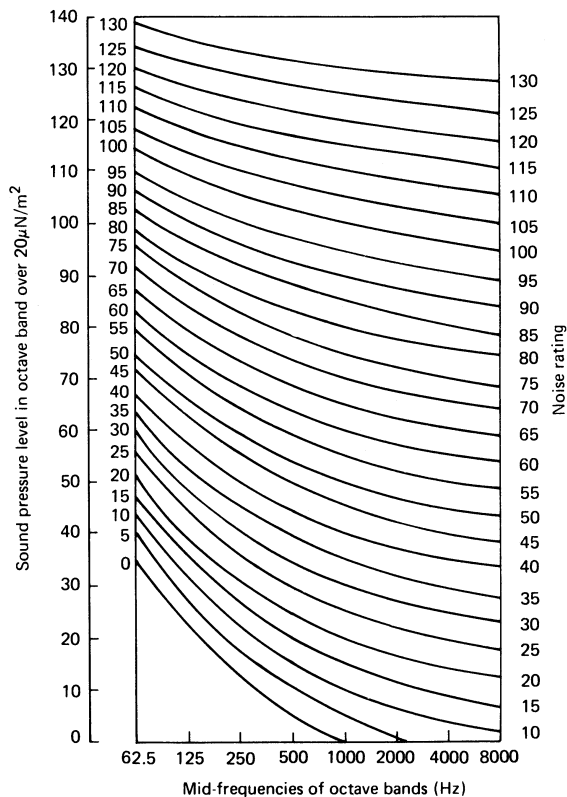

Figure 22.6 NR curves. Each curve is classified by a number corresponding to the speech interference level which was originally defined as the average of the sound pressure levels measured in the octave bands 600–1200, 1200–2400, and 2400–4800 Hz. The maximum permissible loudness level is taken to be 22 units more. Thus NR 30 has a speech interference level of 30 dB and a loudness level of 52 phons; this means that, for effective speech communication, the loudness level in a space designed to have a background level complying with NR 30 must not exceed 52 phons

Table 22.2 Recommended noise ratings*

Situation	NR value
Concert halls, opera halls, studios for sound reproduction, live theatres (> 500 seats)	20
Bedrooms in private homes, live theatres (< 500 seats), cathedrals and large churches, television studios, large conference and lecture rooms (> 50 people)	25
Living rooms in private homes, board rooms, top management offices, conference and lecture rooms (20–50 people), multipurpose halls, churches (medium and small), libraries, bedrooms in hotels, etc., banqueting rooms, operating theatres, cinemas, hospital private rooms, large courtrooms	30
Public rooms in hotels, etc., ballrooms, hospital open wards, middle management and small offices, small conference and lecture rooms (< 20 people), school classrooms, small courtrooms, museums, libraries, banking halls, small restaurants, cocktail bars, quality shops	35
Toilets and washrooms, drawing offices, reception areas (offices), halls, corridors, lobbies in hotels, etc., laboratories, recreation rooms, post offices, large restaurants, bars and night clubs, department stores, shops, gymnasias	40
Kitchens in hotels, hospitals, etc., laundry rooms, computer rooms, accounting machine rooms, cafeteria, canteens, supermarkets, swimming pools, covered garages in hotels, offices, etc., bowling alleys, landscaped offices	45

NR50 and above
 NR50 will generally be regarded as very noisy by sedentary workers but most of the classifications listed under NR45 could just accept NR50. Higher noise levels than NR50 will be justified in certain manufacturing areas; such cases must be judged on their own merits

Notes

1. The ratings listed above will give general guidance for total services noise but limited adjustment of certain of these criteria may be appropriate in some applications.
 2. The intrusion of high external noise levels may, if continuous during occupation, permit relaxation of the standards but services noise should be not less than 5 dB below the minimum intruding noise in any octave band to avoid adding a significant new noise source to the area.
 3. Where more than one noise source is present, it is the aggregate noise which should meet the criterion.
 4. NR ≈ 4B-A value - 6.
- *Courtesy of CIBSE.

In conditions of adverse background noise the acceptability of differing noise sources may not depend on their absolute level and frequency but on their relationship with one another.

Outside the areas of normal sedentary or light industrial environments noise can rise to levels which may be injurious to health. At 90 dB-A or higher, exposure to the noise in confined spaces can be tolerated only for specific periods, e.g. 8 h at 90 dB-A, 2 h at 96 dB-A and 0.8 h at 100 dB-A.

22.2.5 Widening the environmental specification

The traditional criteria for comfort have already been identified as temperature, humidity, illuminance and noise.

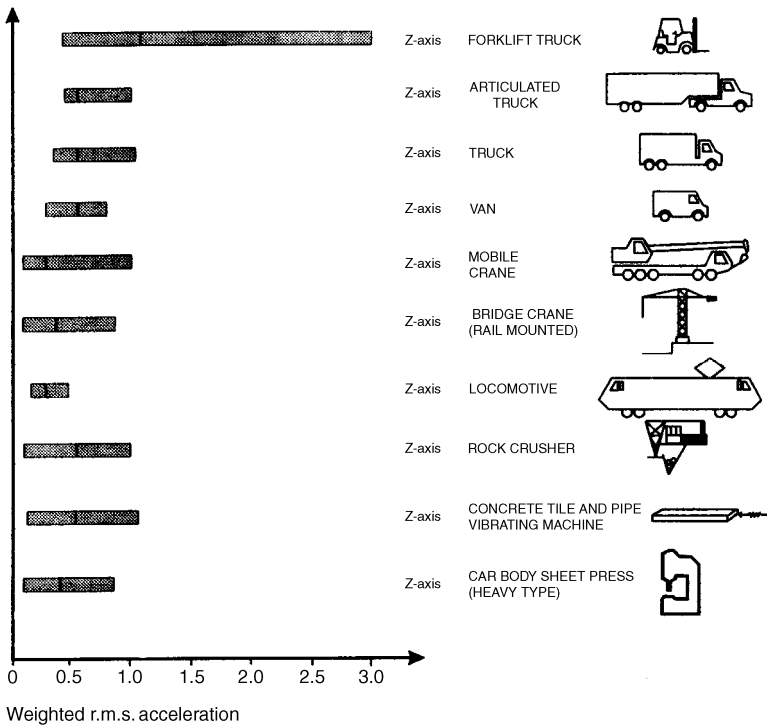

Figure 22.7 Examples of extra noise systems

There is much debate on the need to extend the criteria for defining a modern working environment which is comfortable and healthy. The range of additional possibilities is vast and it will take time before any of them become fully recognised and accepted nationally and internationally.

22.2.5.1 Comfort criteria

There are several comfort criteria which are commonly accepted as being important but do not form part of the current environmental specification.

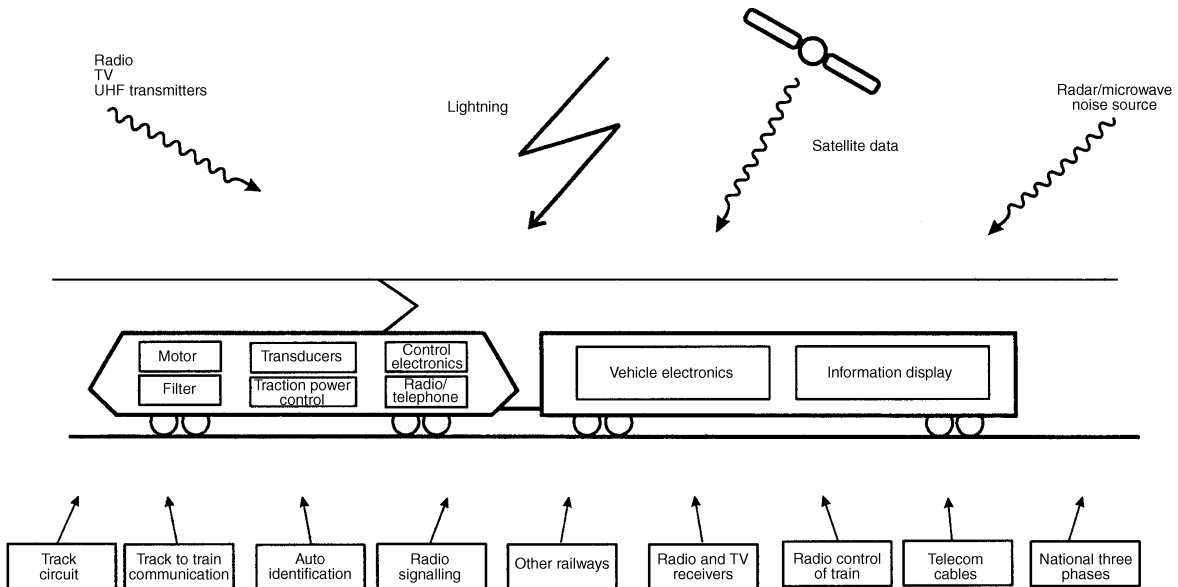

Figure 22.8 Examples of noise sources and disturbances in the railway environment

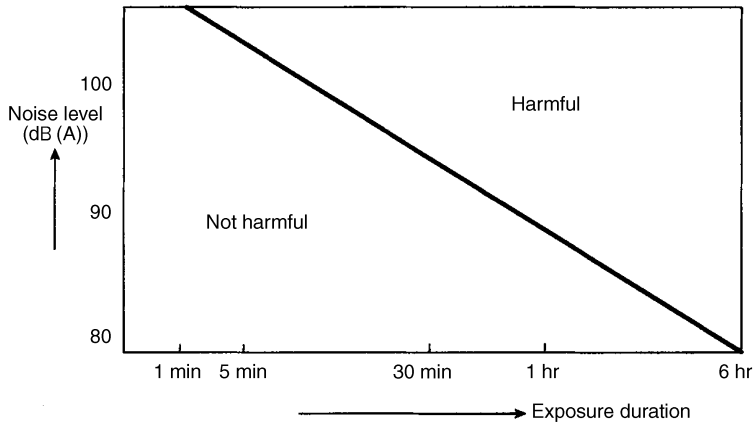

Figure 22.9 Harmful and non-harmful noise level

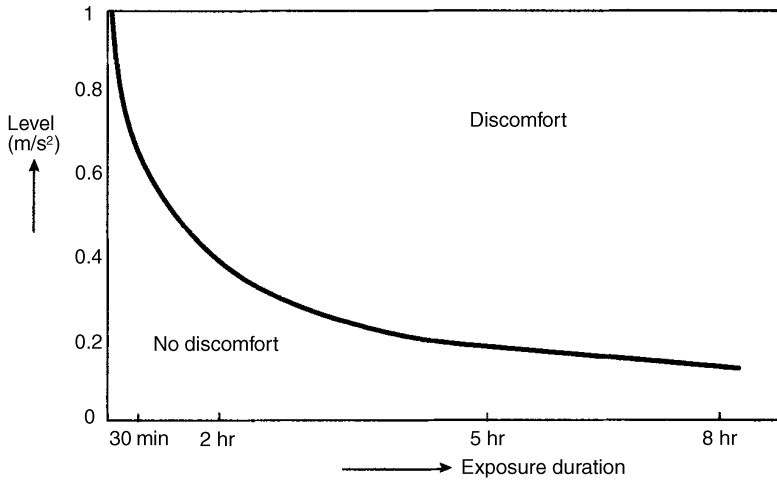

Figure 22.10 Body vibration levels (comfort and discomfort)

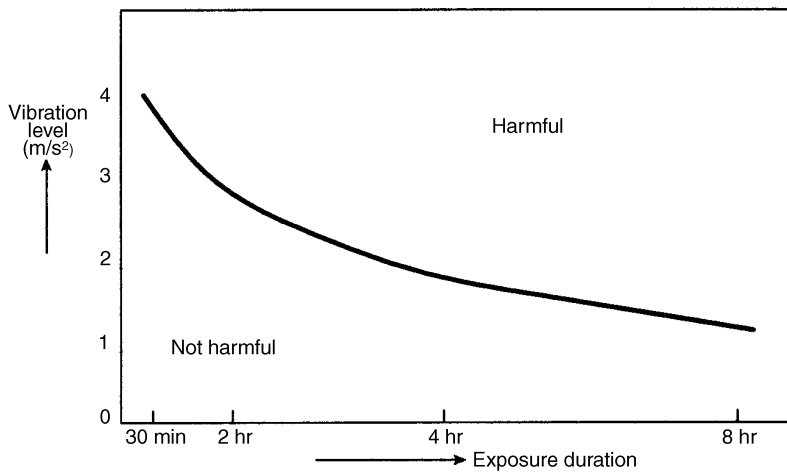

Figure 22.11 White finger vibration

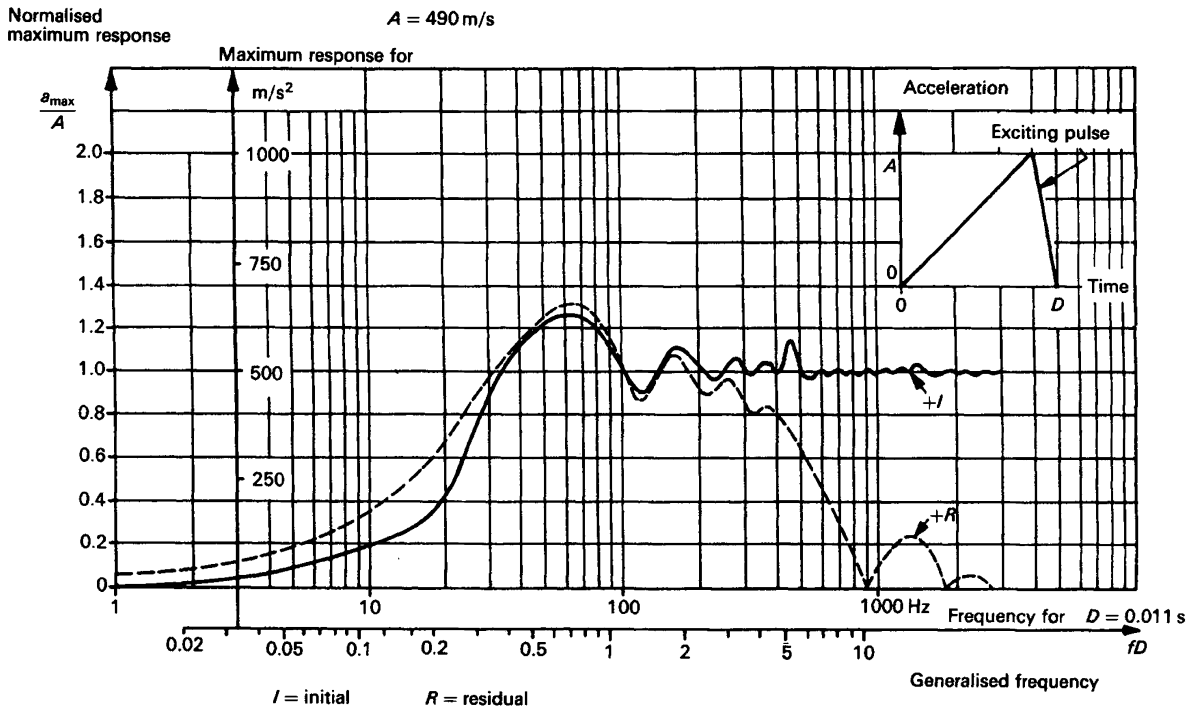

Figure 22.12 Maximum (annoyance) noise levels

Fresh air change and air movement These criteria are less likely to be part of the project brief and are commonly selected by the designer. Design guidance is available and quantitatively defined in professional handbooks and selection is a function of user needs and design experience. Their more explicit specification should be addressed.

Glare, veiling reflections, daylighting, luminance, etc. This group of criteria, like fresh air and air movement, are rarely specified in a project brief or specification. They too are part of the designer's evaluation and selection process and suitable guidance is available. There are current research and study projects examining a range of postulated potential problem areas relating to light sources, systems and the health of the working population. A familiar example is the unsuitable lighting arrangements for occupants using display terminals. There is a publication from the Chartered Institution of Building Services Engineers (CIBSE) entitled *Lighting for Visual Display Terminals*, which addresses this problem.

22.2.5.2 Colour finishes

There is another group of parameters which needs more consideration, some within the control of the architect, others the responsibility of the building-services engineer, and all of them require a co-ordinated approach by both disciplines. Colour finishes in a building and their reflectances, i.e. the amount of light which strikes the surface and is then reflected, are extremely important in terms of occupant satisfaction, and this applies as much to the furniture and equipment as it does to the walls, ceilings and floors. The same point could be made about the colour tint chosen for many window solutions, with the added point that it can detrimentally affect the occupants' perception of

the outside environment. This group of criteria may sound somewhat esoteric in terms of comfort and health, but they do require objective review and further research.

The recognisably engineering factors which may enter more directly into future environmental standards are listed below.

- (1) *Mean radiant temperature*—the effect of large hot or cold surfaces.
- (2) *Infra-sound*—the possible effect of low-frequency vibration
- (3) *Mains flicker and ultraviolet radiation from luminaires*—current studies and improvements in technology suggest that these are not, and need not be, problems.
- (4) *Ionisation*—the effect of negative or positive ions in the air; an area of continuing debate and argument.
- (5) *Information technology (IT) acoustics*—the effects of the various levels and frequencies of noise emanating from IT equipment may have a marked effect on occupancy comfort and fall outside the traditional specified noise criteria.

The parameters listed above are probably the most likely candidates to have a direct bearing on conventional environmental comfort, but there are other factors which may affect our comfort and health at work. They can be split into three further groupings.

22.2.5.3 Pollutants

Modern society recognises the multiplicity of pollutants in our environment generally, but the following identified groups specifically affect the built environment and comfort:

- (1) tobacco smoke;
- (2) fibres and dusts (mineral, paper, ink from printers, etc.);

- (3) volatiles and organic vapours (from adhesives, etc.);
- (4) micro-organisms (bacteria, viruses, spores, dust mites, etc.); and
- (5) carbon dioxide.

All these pollutants, which may in some cases appear as odours, are created within the working environment, and very little is known about their concentrations, and the short- or long-term exposure effects at differing concentrations. Even less is known about mixtures of these contaminants and the possible 'cocktail' effect. It may be that a very small percentage of the working population is allergic to one or more of these pollutants. As the identified pollutants can exceed three figures, any summation of such allergies could conceivably affect a relatively large percentage of the occupants. On a longer term view, if any pollutants are identified as causing such problems,³ their source materials could be banned, or fresh air change rates could be increased to lower the concentrations to safe levels—but only to a limited extent.

A recent study and tests by the Building Research Establishment, Garston on a UK building with a history of sick building syndrome (SBS) has indicated that a reduction in the dustmite population has also reduced the level of SBS complaints in the treated area.

22.2.5.4 Psychological factors

The debate on comfort and health covers both the obvious and the less frequently addressed criteria which affect our physical and physiological reactions to our environment. It also extends to consideration of the psychological factors which are outside the professional competence of the architect and engineer. Designers may in future be guided by medically orientated research into design solutions which could alleviate the effect of factors, such as:

- (1) lack of job fulfilment;
- (2) repetitive/boring work;
- (3) lack of privacy;
- (4) lack of individual identity;
- (5) perceived lack of control over 'personal' environment; and
- (6) poor management.

22.2.5.5 Sick building syndrome

Until recent times the design of building services was a function of an environmental specification which had to be met to achieve comfort. Nowadays the designer has to deal with several medically classified criteria apart from the, as yet, unresolved problems associated with SBS. Engineering designers are not professionally qualified to assess medical risks, but they can design to alleviate or eliminate such risks once they have been identified. Thus, design of buildings and building services can certainly contain the risks associated with Legionnaires' disease (and its associated family of illnesses), and radon, and they must always be considered in the design process. Less clearly defined, but possibly hazardous, are the effects from electromagnetic radiation generally, and high-voltage overhead cables in particular. Design teams may need to use consultant medical input as part of the design processes of the future.

The subject of SBS and its relationship with environmental comfort deserves some specific attention. As it is widely mentioned but not clearly understood. The World Health Organisation (WHO) identifies a range of symptoms for

SBS which cause genuine distress to some building occupants, but cannot be clinically diagnosed and therefore cannot be medically treated. They typically include:

- (1) stuffy nose;
- (2) dry throat;
- (3) chest tightness;
- (4) lethargy;
- (5) loss of concentration;
- (6) blocked, runny or itchy nose;
- (7) dry skin;
- (8) watering or itchy eyes; and
- (9) headache.

Affected individuals may suffer from one or more of these symptoms and the syndrome is characterised by the additional feature that the symptoms are said to disappear soon after the affected people leave the building.

Is it important? Sick building syndrome was reported as long as 30 years ago, but its significance, or apparent tendency to increase, has only been apparent over the last few years. Recent research^{4,5} has indicated that it occurs more often in air-conditioned buildings than others, but as it does occur in heated and naturally ventilated buildings, the cause cannot simply be ascribed to air conditioning. Overall comfort and health in buildings cannot be satisfied by the heating, ventilating and air conditioning (HVAC) industry in isolation.

While SBS may be classified as an illness, there is no absolute proof that it is caused by any one factor or combination of factors. A large number of studies are being carried out,⁶ often initiated because of the high level of occupant dissatisfaction or SBS symptoms in the working environment.

There is a body of evidence which suggests that levels of comfort, health or SBS may be caused by a combination of factors, but the mix and the weighting against each is indeterminate at present. Any of the non-medical parameters previously identified may individually, or in combination, contribute to SBS. To the list must be added design which does not conform to the current best practice and the quality of maintenance and hygiene in buildings.

22.2.6 Machines and processes

Apart from comfort criteria for personnel, there are two other areas where environmental conditions may be important: machine rooms and process plants. The former covers such spaces as computer rooms and medical machine areas; and the latter, areas such as electronic manufacturing or food processing factories. In many ways the criteria are similar to those for personal comfort, but there may be requirements for closer limits and, in particular, air filtration becomes a significant factor, the number and size of particles being very closely defined according to the process. In certain critical processes the air movement patterns are also specified, laminar flow probably being the most difficult to achieve. While temperatures are often specified with limits of not greater than ± 0.25 or $\pm 0.5^\circ\text{C}$, with humidities to $\pm 2\%$ r.h. or better, two points should be made. Limits specified may be unnecessarily stringent and need to be questioned. As an example, computer rooms in the past needed close limits if the machines were to operate correctly; but nowadays this is not normally necessary. The second point concerns the achievement of conditions throughout the treated space. Strictly, the specified conditions can normally be achieved only at the point of detection and control, the variation throughout the remainder of the

space being largely dependent on good plant design and distribution of the heating and cooling media.

22.2.7 Safety requirements

In environmental control the specified conditions and their limits have to be achieved, but generally only during normal periods of occupation. It is therefore necessary to consider the environmental conditions necessary under abnormal circumstances. Examples include: (1) emergency or maintained lighting levels when the normal system breaks down or during unoccupied hours, (2) the low limit temperatures to be maintained to prevent freezing or damage to equipment and furniture, and (3) the maintenance of humidity below a specified dewpoint condition to prevent condensation on cold glazing.

22.3 Energy requirements

To achieve comfort conditions energy is required. The selection of electricity, gas, oil, solid fuel or alternative energy sources is a function of the required conditions, the plant selected, the economics, availability of supply, client preference and, to some extent, crystal-ball gazing.

The calculation of the energy necessary to achieve a particular set of environmental conditions is based on a number of concepts ranging from the simple to the complex and covering both the actual loads for heating and cooling the spaces and the plant sizing to deliver these loads. More sophisticated techniques have been developed to improve the accuracy of calculations and predictions in terms of heating or cooling loads and energy consumption. It is necessary to remember that the more precise figures derived from these techniques are valid only so long as the buildings to which they are applied are built with the same precision and with materials having the same indices used in the calculations. Care must therefore be exercised to ensure that the calculation procedures do not aim for an order of certainty that cannot be achieved in normal construction.

22.3.1 Steady-state loads

In its simplest form the steady-state heat load for a space within a building may be defined as

$$Q = [\Sigma UA + \frac{1}{3}NV]\Delta\theta$$

where Q is the energy required (watts), U is the thermal transmittance of any element surrounding the space ($\text{W}/\text{m}^2\text{K}$), A is the area of the element (m^2), $\Delta\theta$ is the temperature differential across the element ($^{\circ}\text{C}$), V is the volume of the space (m^3), and N is the number of external air changes per hour (h^{-1}).

The thermal transmittance of a wall, roof, floor, etc., is based on an electric circuit analogue. Normally each wall, etc., is a laminar structure of parallel layers of different materials and air spaces, each having a thermal resistance depending on its composition, thickness and surface properties. Given the thermal resistances (in $\text{m}^2\text{K}/\text{W}$) as R_{si} and R_{so} for the inner and outer surfaces, R_1, R_2, \dots , for the component layers, and R_a for the air spaces, the thermal transmittance (in $\text{W}/\text{m}^2\text{K}$) is

$$U = 1/[R_{\text{si}} + R_1 + R_2 \dots + R_a + R_{\text{so}}]$$

Tabulated U values for a wide range of construction elements⁷ are available for different exposures: some are

given in *Table 22.3*. There are certain factors for which allowances may have to be made to the tabulated figures. The values quoted are for homogenous areas of construction, whereas in practice edge details and corners affect the figures. In addition, cold bridging can affect the values, i.e. the effect of wall ties between the inner and outer skin of the building or the framing round windows. Some examples of the ventilation rates used in normal calculations are detailed in *Table 22.4*.

The use of this method enables the heating load (or sensible cooling load) to be calculated for steady state conditions based on a minimum (or maximum) outside design condition and the additional assumption that the heating (or cooling) system will operate continuously. In practice systems generally operate intermittently and the building behaves dynamically. It is to cater for these factors that the more sophisticated calculations are introduced.

22.3.2 Dynamic or cyclic loads

To examine the dynamic performance of buildings, i.e. the energy requirements or loads under cyclic conditions, a procedure is used where the factors of admittance (Y), surface factor (F) and decrement factor (f) are introduced, the admittance having the greatest effect. The factors are functions of the thickness, thermal conductivity, density, specific heat capacity, position and frequency of energy inputs of each of the materials used in the construction. These have analogues with reactive loads in electric circuits. Consequently, there are phase changes ($\phi_y, \phi_F, \text{ and } \phi_f$) associated with them which, because the fundamental frequency is one cycle per day, are expressed as time lags/leads to the nearest hour.

The use of these factors leads to some complex equations which define the cyclic heat requirements for the building. The admittance can be thought of as the thermal elasticity of the structure, i.e. its ability to absorb heat; the decrement factor is a measure of how a cyclic heat input is attenuated as it passes through the structure; and the surface factor is a measure of how much of the cyclic input at a surface is readmitted to the space.

On thin structures the admittance equals the static U value; on multilayer constructions the admittance is largely determined by the internal layer. Thus, insulation on the inside of a concrete slab gives an admittance close to that of the insulation alone, whereas if the insulation is within or on the outside of the slab, the admittance value is virtually that of the slab alone. Decrement factors range from unity for thin structures of low thermal capacity, decreasing with increasing thickness or thermal capacity. Surface factors decrease with increasing thermal capacity and are virtually constant with thickness. Sample values of these three factors are shown in *Table 22.3*.⁷

Other factors affecting the load requirements include environmental temperature, solar gains, internal gains and the latent load for air conditioning plants, i.e. the amount of moisture that has to be removed (or added) to the treated air.

Environmental temperature (θ_{ei}) has already been mentioned and it is a concept used in carrying out load calculations, as it defines the heat exchange between a surface and an enclosed space. Its precise value depends on room configuration and the convective and radiant heat transfer coefficients of the surfaces. For the UK and hot climates it may be shown that

$$\theta_{\text{ei}} = \frac{1}{3}\theta_{\text{ai}} + \frac{2}{3}\theta_{\text{m}}$$

Table 22.3 Thermal transmittance, admittance, decrement and surface factor for various constructions*

Construction (outside to inside)	U (W/m ² K)	Admittance		Decrement		Surface factor	
		Y (W/m ² K)	$\omega\psi$ (h)	f	$\phi\psi$ (h)	F	(h)
<i>Brickwork</i>							
220 mm brickwork, unplastered	2.3	4.6	1	0.54	6	0.52	2
220 mm brickwork, 13 mm dense plaster	2.1	4.4	1	0.49	7	0.53	1
105 mm brickwork, 25 mm air gap, 105 mm brickwork, 13 mm dense plaster	1.5	4.4	2	0.44	8	0.58	2
105 mm brickwork, 50 mm urea-formaldehyde foam, 105 mm brickwork, 13 mm lightweight plaster	0.55	3.6	2	0.28	9	0.61	1
<i>Concrete blockwork</i>							
200 mm heavyweight concrete block, 25 mm air gap, 10 mm plasterboard (on dabs)	1.8	2.5	1	0.35	7	0.64	0
200 mm lightweight concrete block, 25 mm air gap, 10 mm plasterboard (on dabs)	0.68	1.8	2	0.47	7	0.82	1
<i>Roofs—pitched</i>							
5 mm asbestos cement sheet	6.5	6.5	0	1.0	0	0.35	0
5 mm asbestos cement sheet, loft space, 10 mm plasterboard	2.6	2.6	0	1.0	0	0.74	0
10 mm tile, loft space, 25 mm glass-fibre quilt, 10 mm plasterboard ceiling	0.99	1.1	2	1.0	1	0.90	0
<i>Roofs—flat</i>							
19 mm asphalt, 75 mm screed, 150 mm cast concrete (dense), 13 mm dense plaster	1.9	5.7	1	0.34	8	0.50	2
19 mm asphalt, 13 mm fibreboard, 25 mm air gap, 25 mm glass-fibre quilt, 10 mm plasterboard	1.0	0.97	2	0.99	1	0.92	0

* Extracted from CIBSE Guide Section A3. Sample values from schedules. Courtesy of CIBSE.

where θ_{ai} is internal air temperature and θ_m is mean surface temperature.

Solar gains affect load calculations in two ways. First, there is the effect of solar radiation on the heat transfer characteristics of the building fabric, which is covered by the use of a parameter known as sol-air temperature (θ_{eo}). The definition of θ_{eo} is that temperature which, in the absence of solar radiation, would give the same rate of heat transfer through the wall or roof as exists with the actual outdoor temperature and the incident solar radiation, i.e. it is an artificial outside temperature to take into account the effects of solar radiation. The second factor covers the direct solar radiation gains through windows, some of which have an immediate effect and some of which is absorbed into the internal structure and readmitted subsequently. Both types of gain affect energy consumption, but in terms of load they are ignored for heating calculations and included for air conditioning load purposes.

Internal gains from lights, machines and occupants may be substantial. Again, in heated buildings the gains affect the energy consumed by the environmental plant but are not normally taken into account in calculating the design load (the energy input required for the coldest day). For air conditioning loads the inclusion of these gains is most important.

Latent gains are ignored in heated buildings but for air conditioning a considerable proportion of the maximum

cooling load may consist of latent cooling, i.e. the removal of excess moisture from the air because of the use of fresh air for ventilation and internal gains from occupants and, possibly, processes.

22.3.3 Intermittent heating and cooling

The calculation of loads for steady-state and cyclic situations leads naturally to consideration of the effects of running the plant intermittently to satisfy only the specified environmental conditions during periods of occupation. Inherent in this are the following.

- (1) The preheat period necessary to bring the building up to temperature under varying climatic conditions—in particular, on the coldest day for which the load is calculated.
- (2) The thermal response of the building during preheat, which will depend on its construction, insulation and ventilation.
- (3) The thermal response of the plant when first switched on.
- (4) The ratios between preheat, normal heating and plant-off periods.
- (5) Relative running and capital costs.

Table 22.4 Air infiltration rates for heated buildings*

Building	Air infiltration rate (h^{-1})
Assembly hall, lecture halls	1/2
Canteens and dining rooms	1
Churches and chapels	1/2
Dining and banqueting halls	1/2
Flats, residences, and hostels	
Living rooms	1
Bedrooms	1/2
Bathrooms	2
Hospitals	
Corridors	1
Offices	1
Operating theatre suite	1/2
Wards and patient areas	2
Hotels	
Bedrooms	1
Laboratories	1
Offices	1
Restaurants and tea-shops	1
Schools and colleges	
Classrooms	2
Lecture rooms	1
Shops and showrooms	
Small	1
Large	1/2
Department store	1/4
Fitting rooms	1½
Swimming baths	
Changing rooms	1/2
Bath hall	1/2
Warehouses	
Working and packing spaces	1/2
Storage space	1/4

* Extracted from CIBSE Guide A4. Extracts from Table A4.12. Courtesy of CIBSE.

While the actual calculations can be complex and related to the dynamic states already mentioned, there are some basic points which illustrate the situation. In a steady state or dynamic analysis with continuous plant operation, loads for particular spaces may be calculated and the output equipment sized on this basis. When intermittent plant operation is introduced, the situation illustrated in *Figure 22.13* is typical.

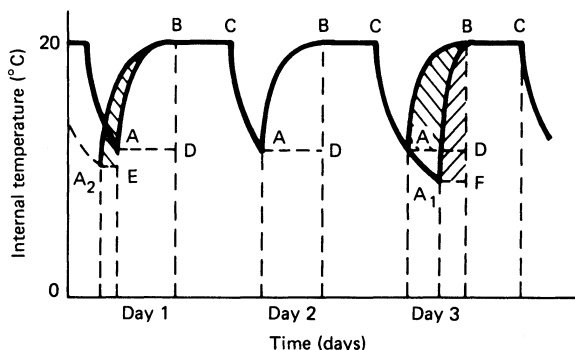
**Figure 22.13** Intermittent-heating temperature/time curves

Here BC represents the period of occupation for which an internal dry bulb temperature of 20°C is required. CA represents the normal temperature decay in the space for a particular set of external weather conditions, and the area ABDA is the energy required to restore the temperature to 20°C at the start of the occupation period.

Because the normal load calculations are based on a constant temperature internally, it is obvious that if the temperature falls as shown, the energy input has to be increased above the steady state requirement, in order to raise the temperature to the required level. Calculating the amount of additional energy becomes part of the load calculations and may be based on variations of the cyclic state techniques already mentioned. The thermal response of the building and the time at which the plant is to be switched on are major factors in the calculations: *Figure 22.13* illustrates some of the variants which have to be taken into account. On the coldest day for which the system is designed the energy input is calculated in terms of the power to satisfy a switch-on time designated by point A. The actual position of A is temperature and time dependent, as indicated by points A₁ and A₂.

Point A₁ represents a situation where the temperature decay has been allowed for longer than that required for A. It is clear that the power input capacity to achieve point B from A₁ must be greater than that for point A, because the differential temperature is greater and the time allowed is reduced. But the actual energy for the purpose is the comparison of areas ABDA and A₁BFA₁. Therefore, apart from the calculations for the load requirements the economics of plant costs against cost in use (energy costs in this case) have to be evaluated.

The second point A₂ represents the situation after a non-standard shutdown (e.g. weekends) when the normal load is based on heating from A. Again it is necessary to calculate the load for condition A₂ or to arrange for alternative operation of the plant so that, for example, the temperature is not permitted to drop below A.

22.3.4 Plant capacity

While it is possible to calculate all the heating and cooling loads for achieving environmental comfort conditions in various spaces, including the sizing of individual output terminals, the selection of main plant to supply the necessary energy is another matter. The actual terminal size for a space has to take into account all the elements already considered, which clearly illustrates that capacity is rarely based on the steady-state load for continuous plant operation. Economic factors can sometimes inhibit optimum selection. The choice of suitable terminal sizes is reflected in the main plant selection, which has to cover the following points:

- (1) heating plant capacity for intermittently heated buildings is normally based on simultaneous peak loads for all the spaces in the building, with such exceptions as the domestic sector, whereas cooling plant assumes diversity between the peak loads in various conditioned spaces (some diversity is permitted for continuously heated buildings).
- (2) heating or cooling plant capacity should be sufficient to cater for process requirements in addition to the environmental load; e.g. the domestic hot water load may be purely for washing but may also include kitchen or restaurant requirements.
- (3) sizing of source units should be such as to permit efficient operation under part-load conditions.

In respect of (3), particularly for multiple boiler or chiller installations, the environmental load in most cases only reaches the design peak for a small percentage of the total operating hours per annum, and the efficiency of boilers and chillers normally falls as their output decreases from the specified design level. It is therefore important to choose the units so that at, say, 25% of design load the operating source units are matched to the requirement to maintain a high efficiency.

The choice of refrigerant in chillers is environmentally important. Chlorofluorocarbons (CFCs) are currently the most common refrigerants in chillers used for commercial purposes and they deplete the atmospheric ozone layer and act as greenhouse gases. Under the internationally accepted Montreal Protocol, CFCs are scheduled to be phased out within the next 5–10 years and alternatives have to be provided which are environmentally safer. The current alternatives may be less efficient refrigerants than the CFCs they replace and more energy will then be required to produce the same cooling output, with a consequent increase in CO₂ released to the atmosphere.

22.3.5 Computer-aided design

The use of the computer for environmental comfort design is generally restricted to calculation of loads and annual energy consumptions, and to check whether the summertime temperature in the building rises to a point where air conditioning is essential.

Computer programs enable far more sophisticated techniques to be employed without laborious arithmetic. However, they should be used only as a design tool for the project, which still requires practical knowledge.

The programs for UK use are generally based on detailed extensions⁸ of the techniques already outlined. Among the criteria which can be incorporated are the effects of shading provided by building configurations and overhangs, which affect both the load and energy consumption.

Apart from providing the calculated loads, energy-consumption programmes can provide the annual figures based on hourly weather data over a full year for any location and type of plant, so that a comparison between plants is rapidly available.

22.3.6 Energy consumption

There are three specific points to be identified in considering energy consumption: (1) degree-day figures, (2) energy budgets, and (3) energy targets.

The degree-day is a concept that permits energy consumption in a building to be monitored from year to year against a monthly datum. It is normally used only for the comparison of consumption in heated buildings, although a modified form is being considered for use with air conditioning. Degree-days measure the interval for which the outside temperature drops below a specific value (normally 15.5°C) and the amount by which it does so. The monthly figures are published for various areas. The base of 15.5°C is used in the UK, but other figures are used elsewhere to broadly represent that outside condition for which no system heating is required to maintain a suitable internal temperature: internal gains, etc., are always assumed to provide a rise of several degrees.

The energy budget for a building is the estimated annual energy consumption of a building. It is necessary for the cost-in-use evaluation.

Table 22.5 Energy targets for heated buildings

Building	Consumption per annum	
	(GJ/m ²)	(kW-h/m ²)
Offices ¹	0.47–1.19	130–330
Factories ²	0.68–1.08	190–300
Warehouses ²	0.54–0.97	150–270
Schools ³	0.36–1.26	100–350
Shops ⁴	0.61–1.44	170–400
Hotels ⁴	0.86–1.55	240–420

Notes:

- (i) The figures are for heated and naturally ventilated buildings.
- (ii) The range of consumption is a function of the thermal insulation, air sealing and efficiency of the heating system.
- (iii) Figures are for conventional hours of occupancy and lighting levels. The factory figures include a 20% allowance for process gain.
- (iv) The figures are for the UK.

References:

- 1 BRESCU, *Energy Consumption Guide No. 19, Energy Efficiency in Offices*, October, 1991
- 2 EEO, *Energy Efficiency in Buildings, Factories and Warehouses*, 1988
- 3 BRRCU, *Energy Consumption Guide No. 15, Energy Efficiency in Schools*, September, 1991
- 4 CIBSR, *Applications Manual AMS: Energy Audits and Surveys*, 1991

Energy targets define the design aim for energy use in buildings, related to type, usage and location. The figures may be quoted in terms of power or energy per unit area (e.g. W/m² or kWh/m² p.a.). The official energy unit in SI terminology is GJ/m² p.a., where 1GJ ≈ 278 kW-h. Buildings are now being designed to meet such energy targets and there is a trend towards making such figures mandatory in certain parts of the world. Table 22.5 lists the targets for a variety of buildings in various locations.

22.4 Heating and warm-air systems

The majority of heating systems in the UK use water as the means of distributing thermal power (with steam as one variant of water). Electricity as a direct source of thermal power is an alternative which has advantages in certain situations but is frequently dismissed on the grounds of comparative energy cost. Water may be utilised for pure heating systems via emitters which produce radiative and convective heating, or for air heating systems where fan assisted devices produce warm air via a heat exchanger. The characteristics of boilers, by both type and use, are generally known in the engineering professions and are not covered here.⁹

22.4.1 Radiators

Radiators are the most common form of heating system. There is a roughly equal split between the radiant and convective heat output. On water systems cast iron for radiators has been largely replaced by mild steel. The radiant emission Q is a function of the difference $\Delta\theta_i$ between the temperature of the ambient air and the mean of the internal liquid, according to the expression

$$Q = k(\Delta\theta)^n$$

where k is a constant depending on dimensions and $n = 4-3$ for radiators. Electric radiators and tubular heaters are rarely used outside domestic or small commercial premises and even then only because no other form of heating is available.

22.4.2 Convectors

Convectors may be natural or fan convectors: both are common. The natural versions may be in upright cases with top and bottom grilles for air circulation, or used as skirting heating. Their emission may be designated in a form similar to that for radiators, but $n = \frac{1}{35}$ for upright types and 1.27 for skirting versions. Water flow rate can have a considerable effect on emission. Fan convectors provide a form of air heating. They are normally controlled by switching on and off by means of a thermostat. In the emission formula, n is unity.

Convectors using electrical power for the thermal output are unusual compared with the water power versions.

22.4.3 Warm-air systems

Warm-air systems vary from domestic units to industrial systems. Some sophisticated versions which duct warm air through a large building complex may be treated as air conditioning systems without cooling and humidification elements, but such systems are rare.

A substantial proportion of heaters, with nil or minimal ductwork, are freestanding and distribute air locally on a recirculation basis without the introduction of fresh air. If the air volume is freely distributed, the complete unit is usually started and stopped by means of a space thermostat, or one mounted in the recirculation air inlet to the unit. Where the air flow is restricted, by manual or thermostatically controlled dampers to control the temperature by varying the air flow, it is necessary to ensure that the unit and fan are switched off when the air volume is reduced to a predetermined level.

The primary source of thermal energy for these units may be oil, gas or electricity. The latter is used in domestic units and in some commercial applications.

22.4.4 Storage heating

Underfloor heating can be operated with hot water or electrical energy as the thermal medium. The floor construction, covering, thermal time constant, temperature control and the idiosyncrasies of the user make system calculation difficult, and underfloor heating is consequently uncommon. Its future may depend on using low-grade heat spread over large emitting surfaces at temperatures of 23–30°C, possibly with solar panels as the heat source.

Storage heaters, electrically fed, are employed in domestic and commercial premises, which avoids the need for central heating plant. For adequate thermal capacity the units are unavoidably heavy (60–300 kg), with ratings of 0.5–6 kW. The refractory heat-storage blocks have heating element temperatures up to 900°C. The heaters are normally run on off-peak supply, emission from the units being regulated to match the periods during which the heat output is required. ‘Natural’ storage units radiate during the off-peak charging period. They are generally less satisfactory than ‘fan assisted’ units, which are insulated to restrict output during charging, the output being controlled by timers and thermostats to start and stop the fan, which controls most of the heat output.

The charge during the permitted period should be regulated in accordance with internal and external temperatures. Energy regulators are available for this purpose (see Section 22.5.2).

Other systems are based on large and well-insulated water storage tanks, electrically heated off-peak by boilers or immersion heaters. In some cases the storage temperature

may exceed 100°C, which necessitates a pressurised vessel. Water is circulated (or, for the high-temperature case, injected) into conventional heating or air conditioning systems during the periods required.

22.4.5 Air conditioning

Air conditioning is the filtering, washing, heating and cooling of air to achieve specified temperature and humidity levels. In temperate climates building design and services can usually achieve reasonable comfort conditions without air conditioning, but a system may be found necessary (a) if the extreme conditions are not tolerable, (b) if the building design requires it, (c) if urban noise and dirt have to be reduced, and (d) if internal heat gains (e.g. computer rooms) have to be accommodated.

In an air conditioning system air is moved by fan power through the relevant space, which results in a physical sensation of air movement quite unlike that in normal heated spaces and with simple air heating. Clients and occupants have to be forewarned of this, otherwise there is a likelihood of complaints about the environment which are unwarranted.

22.4.5.1 Systems

Most systems have a section of plant which adjusts the humidity, to ensure that air passed into the conditioned spaces is suitable for the specified humidity (a ‘dewpoint’ condition of about 10°C). The dewpoint plant is described in Section 22.5.1.3. After dewpoint treatment, air is ducted at high or low velocity, for which duct size, fan and acoustic treatment differ. Common systems available are given in the following paragraphs.

Constant volume Normally this uses branched ducting, each branch with a reheater controlled by a space temperature detector.

Dual duct Air from the main plant is split into two duct systems: one carries cold and the other carries preheated air. Both ducts traverse the building. Each space has a mixing unit, connected to both ducts and adjusting the hot/cold ratio in accordance with a room temperature detector.

Variable volume Cold air is distributed to individual spaces through terminals, which throttle the rate of air supply and are controlled by room temperature detectors. Throttling raises the static pressure in the ductwork, the effect being used through a control system to vary the air flow through the supply and extraction fans. Methods of control may be mechanical, or by the several speed control methods applicable to electric motors. As some air is always necessary in a space for ventilation, the terminals do not close in normal operation, and continue to feed in some cooling air. The system is therefore best applied to buildings that require cooling throughout the year, or to systems that incorporate small reheaters (although in the latter case the variable-volume system may be inappropriate). In general, the control of air volume and consequential reduction of air treatment provides a low energy system.

When the air supply from any terminal is throttled back to the minimum design volume, the air distribution pattern will obviously differ from the maximum volume situation. In extreme cases this can create environmentally unacceptable conditions. Many systems are now designed so that the terminal supplies a constant air volume consisting of a variable cooling component from the main air plant with the

remainder provided by recirculated air from the controlled space. This has the effect of maintaining both the correct air distribution pattern and the requisite amount of cooling.

Induction Air is supplied at high velocity to terminal induction units, mainly perimeter mounted, which are fitted with heating and cooling coils. Air is forced out of nozzles in the unit at a velocity high enough to induce entrainment of recirculation air from the space in the discharge jets. Thus, the space air is circulated through the unit, which provides the necessary quantity of conditioned fresh air from the main air plant. The heating and cooling coils are fitted with control valves and sequenced according to the requirements of the space temperature detector, to maintain the correct conditions. An extract system removes the equivalent amount of air to that supplied by the main plant. This type of system is rarely used nowadays.

Fan coil This has some similarity to the induction system but the air is supplied at relatively low velocity to the units, each of which has its own fan. The coil configuration and control is similar to that for the induction unit, but electrically there is a dual requirement for a distribution system to serve the fractional kilowatt one-phase fans and to switch them off during plant-off periods.

Reversible heat pump cycle This system is often used when the main plant air is distributed through a ductwork independent of the units, and sometimes with a non-air-conditioned fresh air supply. Each unit contains a reversible cycle compressor so that it can produce either cooling, or heating in a heat pump mode. The energy transfer medium to and from the units is by a circulating water system with the water temperature controlled at approximately 24°C. Each unit then extracts heat from, or supplies heat to, the circulating water, depending on whether the unit is on the heat pump or chilling cycle mode. The circulating temperature is maintained by sequencing a cooling tower heat exchanger to lower the temperature, or a non-storage calorifier to raise it. The latter may frequently be electrically fed.

Units are generally ‘packaged’ to include controls. The most common have a 1 kW compressor with a one-phase motor and a fan of less than 100 W; but 3 kW (one- or three-phase) units with fans of power more than 100 W are available.

22.4.6 Cooling plant

In essence, cooling plant for comfort conditioning is indicated schematically in *Figure 22.14*, which shows a single machine and tower, but multiple systems are more common. The temperature of the chilled water is controlled by T_{P1} operating the evaporator system and the heat extracted from the primary water appears in the condenser. The cooling tower dissipates this heat and returns the water to the condenser at a fixed temperature dictated by T_C , which by varying the position of valve V_1 controls the amount of tower cooling.

Cooling towers are basically forced or induced draught types, the terms describing the method by which air is drawn past the sprayed water in the tower for cooling. Air-cooled condensers are also used where, in simple terms, the action of the tower is replaced by air blast cooling. Chillers can be of reciprocating, centrifugal, absorption and screw forms, all of which operate on a refrigeration cycle (*Figure 22.15*). The system circulates a refrigerant which has liquid and gas phases and a boiling point at atmospheric pressure

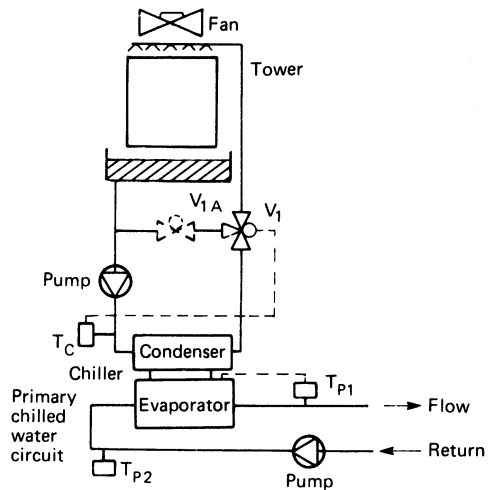

Figure 22.14 Schematic diagram of a single chiller and cooling tower. V_{1A} is an alternative valve position for V_1 , and T_P is an alternative to T_{P1} for specific cases only

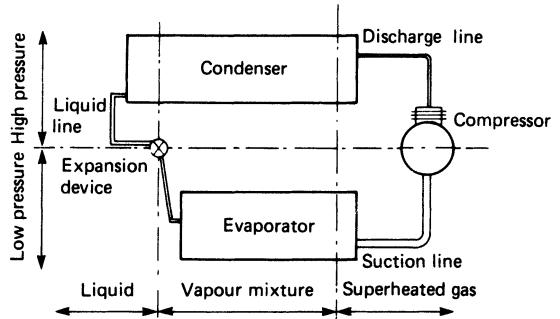

Figure 22.15 Scheme of a vapour-compression refrigeration cycle. (Courtesy of ASC Ltd)

well below that of water. Heat is absorbed by the gaseous and liquid mixture in the evaporator which then becomes a superheated gas: the absorbed heat is extracted from the primary chilled water circuit (*Figure 22.14*), and this is the prime function of the whole system. The gas is then passed through the compressor, which raises the gas pressure and also its boiling (or condensing) point. The condenser then extracts heat from the gas at this higher temperature and condenses it to a liquid again at a relatively high temperature and pressure: this process extracts heat from the refrigerant using the higher temperature water available in the tower circuit (*Figure 22.14*). The liquid then passes through the expansion valve which reduces both the temperature and pressure of the liquid as it expands to the gaseous and liquid mixture state for the cycle to repeat. The use of the expansion device does not alter the total heat content of the fluid.

Chillers¹⁰ can be made by manufacturers operating internationally, motors may be rated (as in the USA) on a basis of 60 Hz, and may not be suitable for working on a frequency of 50 Hz. Again, 60 Hz control circuitry for one voltage may require modification for 50 Hz and a different voltage. Both input and output are expressed in kilowatts. This may cause confusion, because the output is 3–4 times the input, indicating the ‘coefficient of performance’ of the system.

Cooling towers have caused some outbreaks of Legionnaires' disease and there are certain situations where their use may be forbidden or restricted, particularly for hospitals and medical facilities. The alternatives, which are evaporative condensers or air blast coolers, use more energy per unit of heat rejection. Where cooling towers are properly maintained, with suitable water treatment, the risk is minimal.

22.4.6.1 Chillers

Reciprocating machines or compressors These operate on the compression of the refrigerant in a system analogous to that of an internal combustion engine, except that the 'fuel' is contained in a closed loop and an auxiliary motor drives the pistons. Compressors have various numbers of cylinders (up to 16) and methods of control. Machines are available for inputs up to 150–220 kW, corresponding to outputs up to 500–700 kW.

Centrifugal chillers Centrifugal machines use a rotating impeller which performs the compression operation on the gas by centrifugal force. Figure 22.16 shows how the impeller is included in the system. One- or two-stage compression is normal. The control of output is normally by means of inlet guide vanes (not shown in the figure), which are actuated according to the load demand and alter the angle of entry of the gas into, and the performance of, the impeller.

Standard machines are available for outputs of 500–700 kW or greater, but not below 500 kW. Electric motor drives are most common and they may be hermetically sealed into the machine. The electrical rating is from 1/3 to 1/4 of the output rating and for machines above 500 kW input motors, operated economically at 3.3 kV or higher.

Absorption machines Absorption machines also rely on a refrigeration cycle. Analogy with other systems is best considered with the low-pressure section created by a permanently evacuated or high-vacuum system, and compression achieved by heating. The refrigerant fluid is a mixture of water and a fluid (normally lithium bromide) with an ability to absorb water. However, it is the water that acts as the refrigerant, as it will boil at low temperatures in a partial vacuum.¹⁰

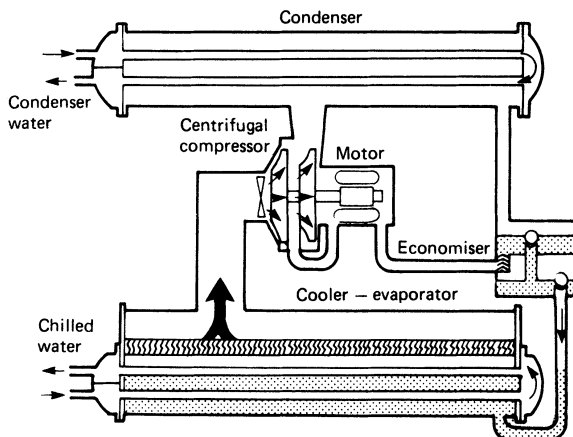

Figure 22.16 Scheme of a centrifugal chiller

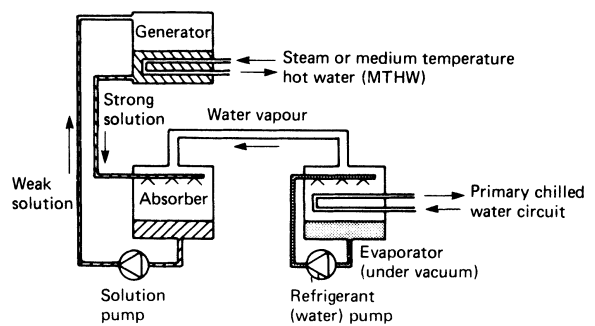

Figure 22.17 Scheme of a basic absorption cycle

Water evaporates more quickly if the surface of a given volume is extended. Rather than using a vessel with a large surface area, this is best achieved by spraying. Figure 22.17 shows how the heat from the cooling load can be picked up by the action of water boiled in vacuum, the chilled water coils being immersed in the sprayed water. Because of its affinity to lithium bromide the water vapour is carried away from the evaporator to the absorber, where it is mixed to provide a lithium bromide solution. If these were the only cycle components, once the lithium bromide had become diluted its capacity for absorbing water vapour would be reduced and an equilibrium position reached whereby no further evaporation of the water and no further useful water cooling could take place.

The weak solution from the absorber can be pumped to a generator where, with the addition of heat, the water vapour can be boiled out of the lithium bromide to produce a strong solution which is returned to the absorber. Here it is sprayed to increase the surface area and, as in the evaporator, increase the capacity to absorb the water vapour from the evaporator. This secondary cycle maintains the absorbent at an operating level, but a water supply is required to replace the water vapour evaporated from the evaporator. If the rejected water vapour from the generator were passed to a fourth vessel, a condenser as shown in Figure 22.18, the vapour at a high temperature could be condensed and returned to the evaporator to complete the cycle. In addition to eliminating the need for make-up water, the fourth vessel provides a vacuum-tight system.

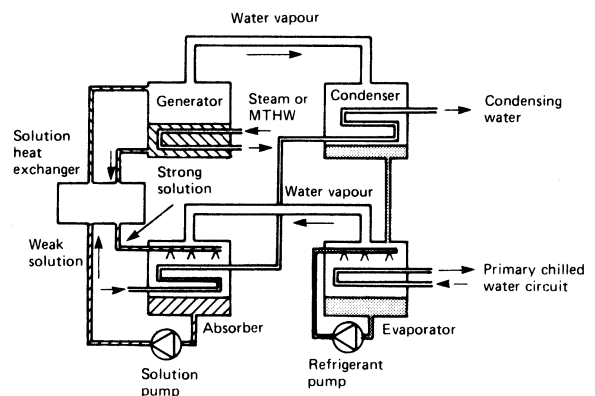

Figure 22.18 Scheme of a full absorption cycle

When the lithium bromide solution absorbs water, heat is generated: it consists of the heat of condensation of the absorbed water plus the reaction heat between the lithium bromide and water vapour. To increase the capacity of the lithium bromide to accept the water vapour, it is kept cool by passing the condenser water first through the absorber and then onto the condenser.

Because the generator is hot and the absorber cool, the cycle efficiency can be increased by a heat exchanger which heats the weak solution pumped from the absorber to the generator and cools the strong solution returning.

In the diagrams used to describe the absorption cycle the flow of water vapour is restricted between evaporator and absorber and between generator and condenser, by the size of the connecting pipes. In practice this is overcome by housing the evaporator and absorber in one shell and generator and condenser in a second. Alternatively, all can be housed in one common shell with a division plate.

The machines are made in two basic size ranges. At the lower end the most common unit is the gas fired domestic refrigerator and direct gas fired units are also made for commercial use in outputs from 10 to 100 kW. The upper range is for outputs of 350 kW and higher, although 1500 kW is generally the minimum.

Energy for heating cycles associated with absorption machines is normally back-pressure steam from a primary process at 200 kPa (2 bar) or from medium-temperature water at 120°C. The steam system makes efficient use of energy which might otherwise be wasted.

Screw machines These belong to a range of positive displacement compressors, claimed to have advantages over conventional compressors in terms of reduced operating noise, lower operating speed and increased thermal efficiency. The machine essentially consists of two mating helically grooved rotors, a male (lobes) and a female (gullies), in a stationary housing with suitable inlet and outlet gas ports (*Figure 22.19*). The flow of gas in the rotors is both radial and axial. Compression is obtained by direct volume reduction with pure rotary motion. For clarity, the description of the four basic compression phases is here limited to one male rotor lobe and one female rotor interlobe space.

- (1) **Suction:** as a male lobe begins to unmesh from a female interlobe space, a void is created and gas is drawn in through the inlet port. As the rotors continue to turn, the interlobe space increases and gas flows continuously into the compressor. Just prior to the point at which the interlobe space leaves the inlet port, the entire interlobe space is filled with gas.

- (2) **Transfer:** as rotation continues, the trapped gas pocket is moved circumferentially around the compressor housing at constant suction pressure.
- (3) **Compression:** further rotation starts meshing of another interlobe space at the suction end and progressively compresses the gas in the direction of the discharge port. Thus, the volume of the trapped gas within the interlobe space is decreased and the gas pressure consequently increased.
- (4) **Discharge:** at a point determined by the built-in volume ratio, the discharge port is uncovered and the compressed gas discharged by further meshing of the lobe and interlobe space. During the remeshing period of compression and discharge, a fresh charge is drawn through the inlet on the opposite side of the meshing point.

Machines are available for outputs ranging from 250 to 2000 kW with both open and hermetic motor drives. The electrical input is from 1/3 to 1/4 of the output.

22.4.7 Cooling storage

Thermal storage systems have traditionally been used for the purpose of heating hot water overnight, see Section 22.4.4. The major advantage is reduced heating costs, not a reduction in overall energy consumed.

The principle has now extended to thermal storage for cooling systems where ice or low temperature phase change materials are used for the purpose, also in well insulated tanks. The charging of the stores is normally carried out at night by electrically powered chillers, although absorption chillers using gas firing or steam/high pressure hot water could be used. The system has several advantages in that smaller chillers can be selected than would be the case if they had to meet the peak daytime cooling load, the power supply system and maximum demand is therefore smaller and, again, cheap tariff electricity can be used for most of the operating load. The use of the systems also reduces the amount of chlorofluorocarbons (CFCs) or hydrochlorofluorocarbons (HCFCs) used in the air conditioning systems and can claim to be environmentally attractive.

All thermal storage systems need to be evaluated in terms of their pros and cons. The advantages mentioned above have to be carefully weighed against the costs of additional storage space, which can be large.

22.5 Control

The importance of controls to achieve comfort conditions has always varied according to the sophistication of the plant to which they are applied, the conditions specified and the economics of providing them. With cheap energy, simple control systems were the norm and comfort conditions were often of low priority and specified only as minimal levels. Energy is now expensive and comfort conditions are considered a more critical factor of human tolerance. Control systems are therefore commonly applied to all types of environmental system, performing the dual role of maintaining comfort conditions and conserving energy. In this combined role it is significant that for heated buildings in the UK a change of 1°C in normal space temperature will affect the energy consumption by as much as 10%.

The most common parameters considered are temperature, humidity and time. Generically, controls are either electric/electronic or pneumatic. The latter system uses

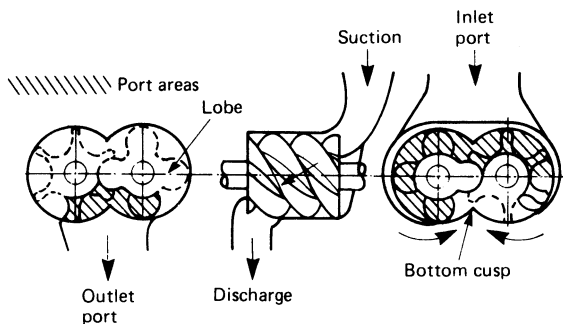

Figure 22.19 Screw-chiller operation. (Courtesy of ASHRAE)

clean dry compressed air as the motive power and is rarely independent of electric/electronic elements, whereas the former system uses electric motive power alone. Pneumatic systems tend to be used where there are many terminal controls, normally on air conditioned systems. Electric/electronic systems are now competitive with pneumatic terminal controls and it is rare to find new commercial buildings with pneumatic control systems. The systems described below are based on non-pneumatic systems. Where run and standby air compressors are supplied for pneumatic control systems, the electrical supply must be capable of starting and running both compressors together.

22.5.1 Controllers

Intrinsically, controllers operate in a two-position or a modulating mode. The former is recognised by on/off thermostats operating a device such as a fan or two-position control valve; the latter is a combination of detector and controller which can vary the position of the control valve over its full range of travel. The type of controller is selected according to the application.

22.5.1.1 Boilers and chillers

The controls for heating and cooling sources are normally supplied as part of the equipment. When multiple sources are used and sequential control is required to achieve a constant heating or cooling flow temperature, the electrical interlocking requirements are significant. *Figure 22.20* shows an arrangement for boilers in parallel. The interlocking necessary to achieve a constant flow temperature, for sequential operation which matches the load requirements, permits any source to lead the sequence, and various standard safety features need to be included. The control interlocks are extremely complicated when using relays and timers, etc., but modern usage normally adopts a software-driven solution which drastically reduces the hardware content of the interlocking package.

22.5.1.2 Heating systems

The control of heating covers the majority of systems in the UK. There are two elements to be considered: central plant control and terminal control. Apart from controlling the flow temperature from the boiler(s), central plant control for radiator and convector systems (the greatest number of heating systems) is carried out mainly by weather compensators. *Figure 22.21* illustrates such a system where the temperature to the load is controlled in accordance with external temperature. In cold weather water is supplied to

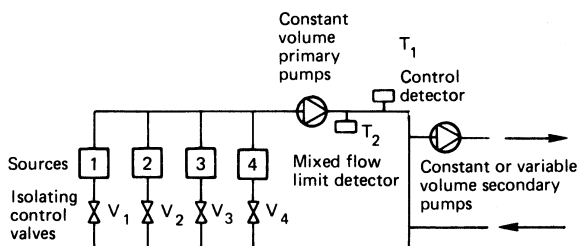

Figure 22.20 Flow-controlled multiple modulating boilers in parallel. Sequential control is from the detector in mixed flow-constant volume through boilers. The system controls any three of four sources.

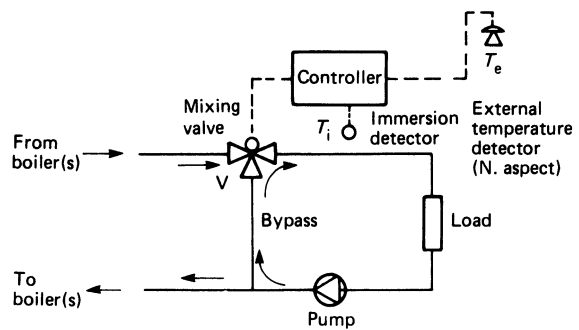

Figure 22.21 Basic scheme of a weather compensated system

the load at the boiler flow temperature, i.e. with valve V closed to the bypass and the setting of T_i corresponding to the boiler control temperature. As the outside temperature rises, a signal from T_e , passed via the controller, resets T_i downwards. T_i controls the position of the motorised valve V to mix water from boiler with water from the bypass (which is the return from the load and at a lower temperature than the boiler flow), to correct the temperature. As the temperature T_i decreases, the output from the terminals is reduced and may be matched to the load by selection of the temperature characteristic. *Figure 22.22*, curve 1, illustrates a typical characteristic.

The actual characteristic varies according to the system design parameters and to heat losses from the building, and may be varied in a number of ways. The characteristic may be generated and adjusted from point A (curve 2) or point B (curve 3) or points A and B (curve 4). A-C represents the limit condition which is governed by the boiler temperature, and may also be used for warm-up situations during which the compensator system is overridden.

A single compensator is incapable of dealing with varying internal loads or solar gain, and additional controls are employed for this purpose. These may be zonal controls, where an additional thermostat and control valve acts as a local trimming device to detect local gains, or terminal controls on each emitter. The latter permits individual temperature control of each space and might appear to make the compensator redundant. However, the compensator

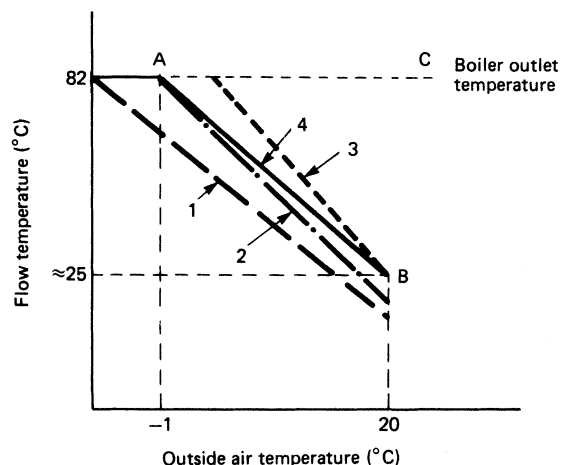

Figure 22.22 Typical compensator characteristics

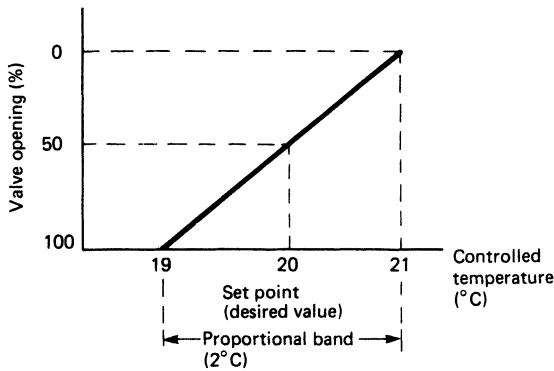

Figure 22.23 Proportional band effect on control setting. The temperature is shown for a set point of 20°C with a proportional band of 2°C

still provides two advantages: heat loss from the distribution mains is reduced as the outside temperature rises, and the reduced circulating temperature prevents individuals from calling for excessive temperatures in mild weather.

The most common terminal control for these systems are thermostatic radiator valves (TRVs), which are self-acting devices requiring no external supply. TRVs have one characteristic which is common to many control systems: they are proportional controllers. This means that they provide their set temperature only at one position of the valve, normally the mid-position as indicated in *Figure 22.23*. A specific change in temperature from this setting is required for the valve to take up any new position, which means that the valve moves from fully open to fully closed over a range of space temperature and that a particular valve position is related to a specific temperature. The sustained deviation from the set point which this describes is known as 'offset'. The range of temperature over which the valve performs its full travel is the 'proportional band' and TRVs have a fixed band which varies according to source and type. Typically the band is 2–3°C: thus, if the setting is 20°C, the space temperature rises to 21°C with the valve fully open and drops to 19°C with it fully closed (a 2°C band). This characteristic is useful in energy conservation terms, as it

decreases the internal temperature at times of greatest load, thus reducing energy consumption, always assuming that the 19°C used in the example is acceptable to the occupants.

Controls for domestic heating systems¹¹ would not normally include a compensator, and TRVs or room thermostats controlling small motorised valves are more common. The use of a single room thermostat starting and stopping the complete system is common, but should be upgraded for both energy conservation and comfort. Warm air systems may be controlled by thermostatically controlled motorised dampers interlocked with the plant heat exchanger and fan.

22.5.1.3 Air-conditioning systems

Air-conditioning system controls are similar to those for heating in respect of the final emitters, i.e. a temperature detector-cum-controller, often proportional in character, which modulates either a control valve or a damper (or both in sequence) to maintain the required temperature. If the terminals depend on the sequential operation of heating and cooling, it is again possible to use the width of the proportional band to provide both comfort and energy conservation. The control may be adjusted to provide heating from 19 to 21°C and cooling from 22 to 24°C, with a dead zone between 21 and 22°C with neither heating nor cooling action.

The control of conditions in the main air-handling plant is a vital element for the overall space environment and is probably the most complex requirement in the heating, ventilating and air conditioning (HVAC) field. The aim is to achieve a stable dewpoint (fully saturated air) condition, which defines the amount of moisture in the conditioned air. The relation between dry bulb temperature, wet bulb temperature, humidity and total heat (enthalpy) is fully defined in psychrometric charts. Attainment of a particular dewpoint condition is sufficient to provide a specified set of relative humidity conditions in a space, taking into account the moisture pick-up (latent gain) from the occupants. *Figure 22.24* illustrates a typical dewpoint plant which contains basic controls and the necessary override and safety features. The details are related to the systems described in Section 22.4.5.

The dewpoint is controlled by T_1 , which sequentially modulates a preheater battery control valve V_1 , dampers D_{1a} , D_{1b} and D_{1c} , which operate in parallel, and a cooler

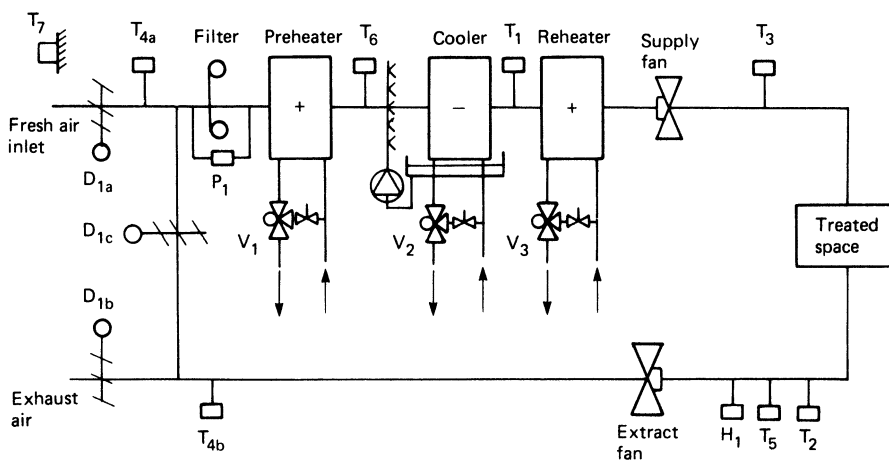

Figure 22.24 Scheme of the dewpoint. T_1 , dewpoint detector; T_2 , return-air-temperature detector; T_3 , low-limit detector; T_4 , enthalpy detectors/comparators; T_5 , boost-limit thermostat; T_6 , frost-protection thermostat; T_7 free cooling enthalpy detector; H_1 , return-air-humidity detector; P_1 , differential pressure switch; V_1 , preheater valve; V_2 , cooler valve; V_3 , reheater valve

battery valve V_2 to maintain a constant saturated temperature condition. The reheater, which is part of many systems, is controlled by the extract temperature detector T_2 , modulating the control valve V_3 to maintain a constant space temperature. The low-limit detector T_3 is sometimes employed in the discharge duct to override T_2 and maintain the discharge temperature above a predetermined limit.

The modulation of the dampers is the 'free cooling mode', using air for cooling prior to the use of mechanical cooling. Conditions can occur where the dampers need to be overridden. When the external temperature rises above the return air temperature (or, more precisely, when the enthalpy, or total heat, of the outside air exceeds that of the return air), it is more economic to cool return air than outside air. A detection device is therefore required to measure the total heat. The enthalpy of the outside air can be measured directly (T_{4a}) as being above the design room value, or by dual detectors (T_{4a}/T_{4b}) which compare the room and outside air total heat conditions. In either case, when the room total heat is exceeded by the outside air, a signal from the device drives the dampers to the minimum fresh air position, determined by the amount of air necessary to satisfy the fresh air ventilation requirements, which may be a statutory design parameter.

At night or during other shut-down periods the dampers are normally driven to the zero fresh air position. They remain in this position after plant start-up until the space temperature reaches a predetermined level as detected by T_5 . During this boost period all the air is recirculated, valves V_1 and V_3 are fully open and the spray coil is de-energised. Thermostat T_6 protects the plant in cold weather conditions. If for any reason the temperature of the preheater drops to approximately 2°C , T_6 operates to shut down the plant and give an alarm.

It is also possible to satisfy the dewpoint condition without mechanical cooling, whenever the enthalpy of the external air is below that approximating to the dewpoint condition. This is accomplished by detector T_7 , which holds off the chiller and cooling-tower plants whenever the enthalpy is below the predetermined level.

In rare cases a humidity detector (H_1) mounted in the extract duct from the conditioned space is provided to monitor excessive or reduced latent gains in the space. It then resets the dewpoint detector (T_1) to compensate.

A differential pressure detector (P_1) fitted across the plant filter is a standard control item to provide a warning of high pressure across the filter for both maintenance and energy conservation purposes.

Some interlocking features are desirable on all dewpoint plants. One is associated with fire defence. It is becoming standard practice, sometimes mandatory, to ensure in the event of smoke or fire that the plant shuts down and that firemen can start the extract fan independently of the supply fan, with the dampers run out of sequence. A frequent associated requirement is for recirculation dampers to be fully closed to facilitate smoke exhaust. The basic dewpoint control, and the various additional functions described, illustrate the possible complexity of the interlocking diagrams, which parallel those of the multiple boiler systems described previously. The sustained offset with proportional controllers makes them unsuitable for this application because the dewpoint temperature control is often critical for the comfort conditions required. Thus, floating or two-term controllers are used which do not suffer from offset.

In energy conservation terms, systems which treat all the air and bring it to a dewpoint condition are inefficient. Alternatives are frequently used, where the cooling and heating coils may be controlled in sequence from the detector

in the return air duct, and humidity control is only employed at the upper and lower limits of the specified conditions, by using the latent cooling capacity of the cooling coil, or injecting moisture, respectively.

22.5.2 Time controls

The use of time switches is generally accepted. On large plants optimum start controls are becoming commonplace. The principle of operation of optimisers is to compare the external conditions with a representative internal condition so that the plant switch-on time is varied to achieve the required internal comfort conditions only at the time of occupation. In contrast, time switches are set to ensure that the conditions can be achieved on the coldest day, which means that in milder weather the building reaches comfort conditions earlier than necessary. Optimisers are therefore used for energy conservation, and can save 7–10% of the energy used with time switch control. The operation is shown graphically in *Figure 22.25*. As in *Figure 22.13*, BC represents the period of occupation and CA the temperature drop for the design coldest day. As the external conditions improve, the decay curve moves to CA_1 , CA_2 , etc., and the switch-on time is calculated by the optimiser and is delayed, moving from S to S_2 , etc. A conventional time switch operating at S when the decay curve is CA_2 would waste energy equivalent to area XYA_2BX . Optimised stop facilities are also available.

22.5.3 Building management systems

Control systems for building services have moved steadily from stand-alone control loops towards arrangements where a high degree of central supervision is provided—largely automatic, with manual override applied for specific circumstances. There has been a progression from electro-mechanical supervisory data centres, through electronic building automation systems to the current energy management (EMS) and building management (BMS) systems which depend on microprocessor/software technology. Energy management is just one, albeit important, of the facilities offered by a BMS, which acts as the controller,

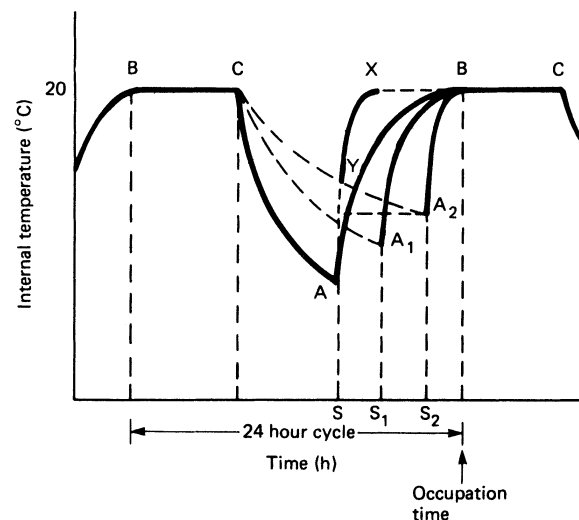

Figure 22.25 Optimised start of heating plant

monitor and fault locator for all aspects of the built environment and can provide a wide range of other management functions.

The latest generation of microprocessor-based systems are now used to replace the traditional stand-alone controllers used in control loops and the means of control has passed from analogue to direct digital control (DDC). On any but the smallest BMS (which can be a single programmable controller with a number of analogue and digital inputs and outputs), the equipment configuration will be similar to that shown in the block diagram of *Figure 22.26*. The data-gathering panels (DGP) in modern systems will be microprocessor based and incorporate levels of software which make them largely independent of the central processor. The main criteria and possible uses are listed briefly below.

Data transmission This may be multiplexed multicore distribution, single or two wire trunks for pulse coded messages, or a fibre optic system. Where remote buildings are coupled to one system British Telecom or Mercury lines may be used for transmission.

Scanning Typically scan times are between 2 and 30s, although the point-to-point scan may be much faster. Multiple scan times can be employed, one for analogue signals and others for high- and low-priority alarms.

Hardware and peripherals These include the following:

- (1) data inputs from two-position and analogue devices, and data outputs for control switching and set-point adjustment;
- (2) outstations, which may be relatively simple data processors or intelligent systems, with stand-alone capability;

- (3) intercom, which may be a feature additional to the transmission system;
- (4) central processor, which contains the memory for automation and alarm functions, often with a back-up power supply;
- (5) operator's keyboard and display unit;
- (6) printer(s) for common or separate logs and alarms;
- (7) visual display units in monochrome or colour;
- (8) permanent displays such as annunciator panels or mimic diagrams.

Software This covers the following:

- (1) alarm priorities;
- (2) alarm inhibiting;
- (3) analogue alarms;
- (4) integration, e.g. energy consumption;
- (5) totalisation, e.g. summation of motor run times, etc;
- (6) time switch, including optimised start;
- (7) event initiated sequences, e.g. an alarm which initiates a specific sequence of operations;
- (8) load shedding and lighting control;
- (9) restart after power failure: prevents electrical overload on restart;
- (10) process control, e.g. the use of the centralised system as the controller for individual loops (DDC);
- (11) optimum damper control (see Section 22.5.1.3);
- (12) security, e.g. patrol tours and card entry;
- (13) interlocking, e.g. the use of software in place of conventional relays, timers, etc;
- (14) fire, i.e. alarms and specific event initiated sequences;
- (15) programmed maintenance, i.e. the use of stored data to produce a work schedule for maintenance and service;
- (16) facilities management.

An example in block form of a building automation system is shown in *Figure 22.26*.

Economics The cost evaluation for a proposed scheme should include consideration of the following:

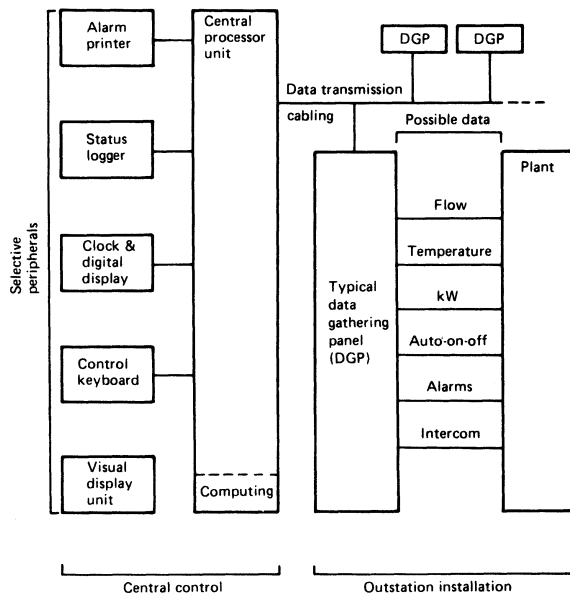

Figure 22.26 Block diagram of a typical building automation system. DGPs will normally include their own software capability for control functions. The central processor unit may range from a main frame machine to a microprocessor unit

<i>Savings</i>	<i>Expenditure</i>
Reduction of energy	Capital cost of system
Reduction in maintenance staff	Interest on capital cost
Increased plant life with programmed maintenance	Additional specialist staff
Use of software for interlocking in place of relays, timers, etc.	Maintenance of the automation system
Avoidance of duplicate systems (e.g. fire and security central consoles)	Preparation of detailed maintenance format
	Collection of data and producing particular software

22.6 Energy conservation

The subject of energy conservation and the efficient use of energy is of interest in all branches of engineering design. The provision of satisfactory environmental conditions consumes such a large fraction of the national energy budget that energy conservation cannot be divorced from comfort. The means of reducing energy consumption range from using less energy by more effective building design and more efficient HVAC systems, to lowering comfort standards and

reclaiming energy that would otherwise go to waste. Lowering comfort standards is a difficult objective to promote. Heat reclaim methods are numerous and in many cases are applicable also to industrial processes, and they often improve the efficiency of existing systems.

There is also the problem of effective maintenance and servicing of existing installations, which can contribute to both energy conservation and satisfactory environmental comfort standards.

22.6.1 Systems

The importance of heat reclaim systems has always been recognised but in practice their application has been very restricted until recently. Because a heat recovery system is frequently part of a sophisticated installation, it should be integrated into the more comprehensive requirements of the design philosophy. Some of the more common systems are described below.

Thermal wheel These are rotating air-to-air heat transfer devices between two separate air streams in parallel and adjoining ductwork. The speed of rotation will not normally exceed 20 rev/min and the heat recovered decreases with speed. The control of energy transfer is effected by varying the speed or the exhaust air quantity passing through the wheel. Normally, only sensible heat is recovered, but versions exist which reclaim latent heat as well. A standard arrangement is shown in Figure 22.27. The temperature of the air supplied to the space (or other elements of the plant) is controlled by varying the speed of the drive motor. Control can also be achieved by bypass dampers to reduce the air passing through the exhaust air section. It is necessary to check that the energy saved by heat transfer is not exceeded by the additional fan power required.

Liquid coupled indirect heat exchanger (run-round coil) This system is simple. The general arrangements are shown in Figure 22.28. The pump may be controlled by an externally mounted thermostat T_1 , which runs the pump whenever the external temperature is below the design exhaust air temperature. Alternatively, a more sophisticated arrangement would be to use a differential thermostat T_{2E} , T_{2S} which runs the pump only when the temperature of the exhaust air is higher than that of the supply air. The capital cost of the plant and the additional pump and fan horsepower must be equated to the energy saved before such a system is adopted.

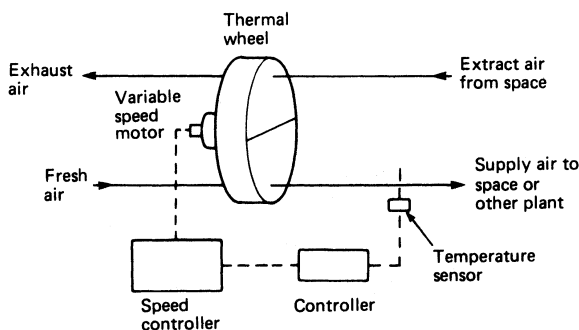

Figure 22.27 Variable speed control of thermal wheel

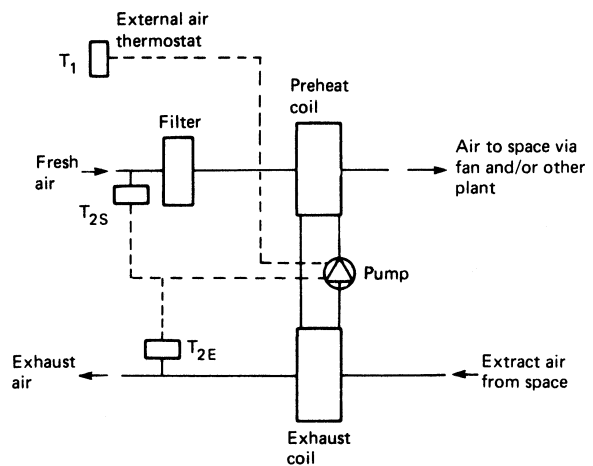

Figure 22.28 Scheme of a heat-reclaim run-round coil. T_1 , T_{2S} and T_{2E} are detectors for different methods of control

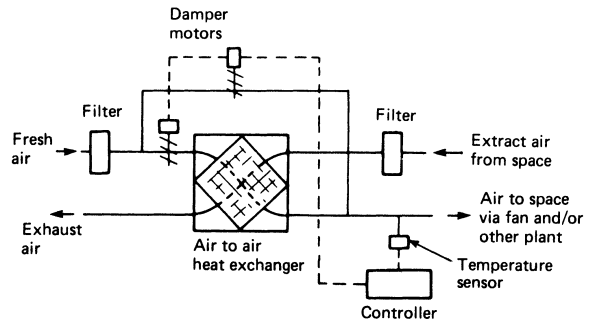

Figure 22.29 Scheme of heat reclaim by an air-to-air heat exchanger

Cross-flow stationary recuperator (air-to-air heat exchanger) This device is an alternative to the thermal wheel but will provide only sensible heat transfer. The general arrangement is shown in Figure 22.29. The control system is similar to the bypass damper arrangement described for the thermal wheel.

Heat pump The use of heat pumps in HVAC systems is increasing. The most common form incorporates a refrigerant compressor unit with evaporator and condenser where the functions of the latter two elements may be reversed to give heating or cooling cycles as required. This arrangement is shown in Figure 22.30, where the heating cycle mode illustrates the generic definition of a heat pump system. This type of unit is described in Section 22.4.5.

Heat pumps are frequently used purely for heating, but whether in this mode or as reversible units, they are available with air-to-air, water-to-water and air-to-water heat transfer. The selection of refrigerant is important to ensure that maximum efficiency is achieved for the specified range of inlet and outlet temperatures.

In some heating applications, particularly where heat is being extracted from outside air, the external coil (acting as the evaporator) will tend to ice up and a defrost control system must be used. This requires an arrangement for

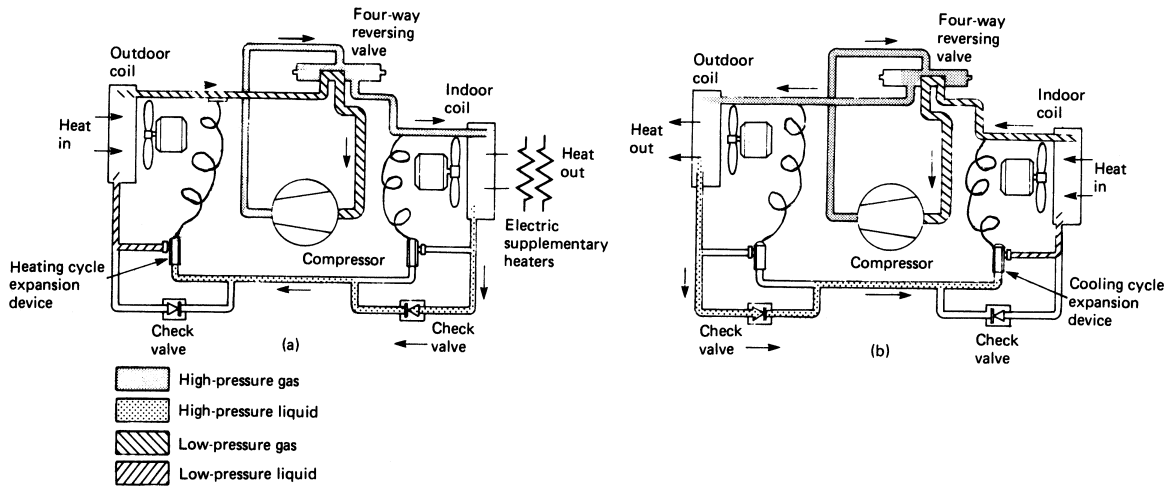

Figure 22.30 Reversible cycle units. (a) Heating cycle (heat pump); (b) Cooling cycle (chiller)

allowing hot gas to be passed through the coil for a short period, or the use of separate electric heaters.

Heat pipe This simple device is becoming an accepted heat reclaim component; it contains no moving parts and can be fitted in a manner analogous to a thermal wheel. Essentially, it consists of a sealed and evacuated tube containing a refrigerant, e.g. Freon, and lined with a wick. The action is shown in Figure 22.31: (a) shows that the application of heat vaporises the liquid refrigerant, which is then cooled at the top of the tube (giving up its latent heat), absorbed in the wick and returned to the bottom of the tube. This system is utilised in heat reclaim as in (b), where banks of tubes replace the thermal wheel in Figure 22.27.

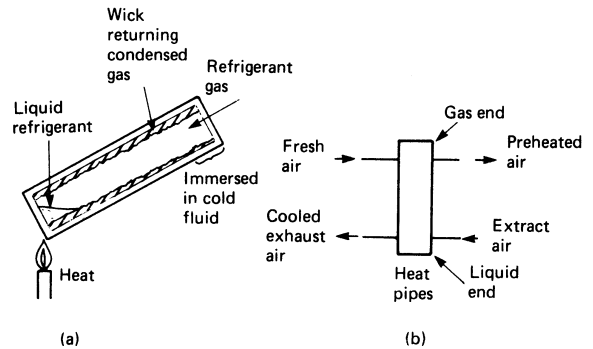

Figure 22.31 Heat pipes for heat reclaim

Double-bundle condenser One common method of heat reclaim normally considered in all air conditioning systems is the double-bundle condenser. Figure 22.14 shows the conventional condenser, but it is obviously advantageous to use the rejected heat rather than discard it in the cooling tower. The arrangement is shown schematically in Figure 22.32, where one tube bundle is used for the tower heat rejection circuit and the other for heat reclaim to the heating systems in the building. The system is controlled in sequence so that the tower circuit is brought into use only when there is no requirement for reclaimed heat. Temperatures of 45°C can be attained from the reclaim circuit without difficulty.

22.7 Interfaces and associated data

Modern buildings continue to become more complex and sophisticated, a fact which is generally accepted. Whether all the complexities are necessary is discussable, but not relevant here. What does need clarification is the treatment of the various interfaces which occur between all the parties involved in the building process starting with the developers/designers and ending with the tenants. If these interfaces are not clearly identified and treated, the environment and its control in the final building will be unsatisfactory and inefficient.

The first stage in this process is recognition that all the design disciplines should be involved with the client from

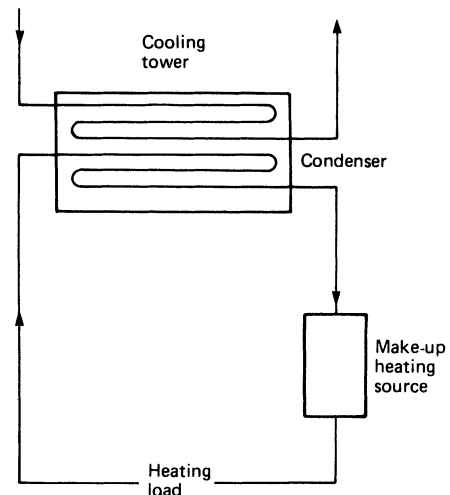
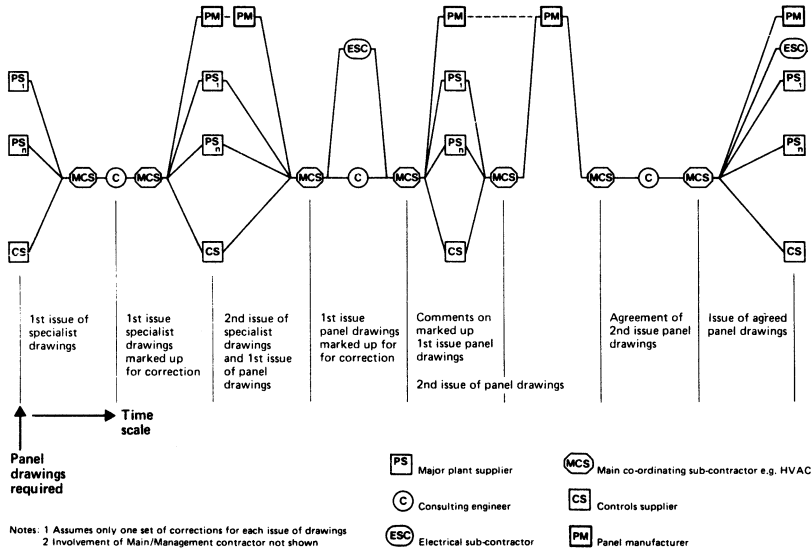

Figure 22.32 Basic scheme of a double-bundle condenser for heat reclaim

BASIC CONTROL PANEL WIRING DIAGRAM PROGRAMME



BASIC SITE CO-ORDINATION FOR CONTROLS AND T&C

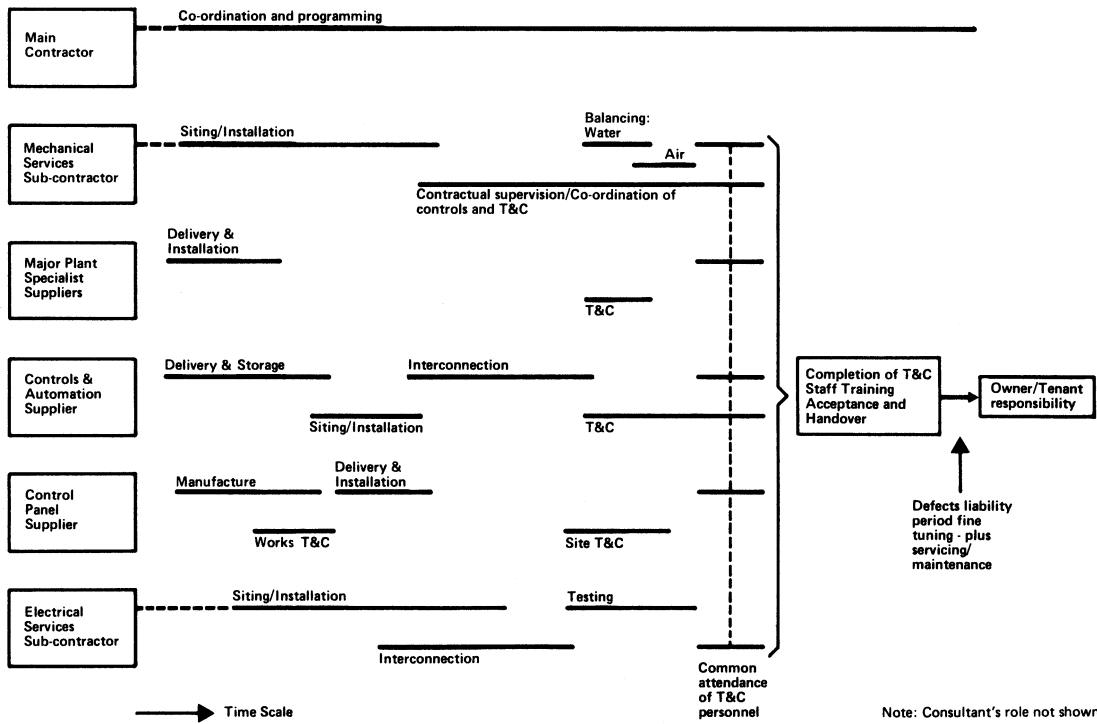

Figure 22.33 Examples of interfaces and co-ordination

the concept stage onwards. Very frequently architects are the only discipline initially involved, followed by the structural engineers and then the mechanical and electrical (building services) engineers. The ultimate tenants and their requirements are all too rarely involved until after the design is completed. With the complexity of modern buildings, the increasing pressures of environmental issues and the multiplicity of interfaces, it is essential that design teams are multidisciplinary in nature (with builder and tenant involvement if possible) from the very inception of the project. Just two examples of how these interfaces affect the way environmental control is achieved are shown in *Figure 22.33*. The first shows the quickest route to obtain approved control panel diagrams and at best it takes many weeks. The second shows how the setting up and commissioning of the environmental controls and automation systems has to be planned.

The interface requirements of the systems shown in *Figure 22.33* refer to well-defined elements in the environmental-control process. When the considerations have to include the more subjective environmental control issues of the greenhouse effect, ozone depletion by chlorofluorocarbons (CFCs), internally/externally created pollutants and the physiological and psychological reactions of occupants to their working environment, the interface problems can be overwhelming. Only a co-ordinated approach by all concerned can achieve the necessary environmental control.

22.7.1 Electrical loads

Environmental control and issues are often inextricably related to energy and its effective use. Mechanical and electrical engineers working on the building services of buildings, often worth half the total cost of the building, have an extremely important role in minimising energy consumption. At one level they need to work with the architect to ensure an efficient fabric design and at the other they need to define electrical loads at the concept stage so that transformers and switchgear can be sized and suitable space provisions made.

Electrical-load figures are supplied in many forms, and at the concept stage in the design process considerable expertise is required to correctly assess suitable figures which will

generally withstand the various changes during the design process. This has to be borne in mind when considering *Figures 22.34* and *22.35*. The curves in *Figure 22.34* represent typical maximum demands for fans and pumps for different types of air-conditioning system, while those in *Figure 22.35* indicate maximum demands for different types of chiller. Lighting load data are voluminous and are best obtained from CIBSE Lighting Division publications, or manufacturers.

References

- 1 *CIBSE Guide Book A*, Section A1, CIBSE, London (1986)
- 2 *Control of Fuel and Electricity, The Fuel and Electricity (Heating Control) Order—Statutory Instrument*, 1974 No. 2160 (1974)
- 3 *Health and Safety. The Control of Substances Hazardous to Health Regulations (COSHH)—Statutory Instrument 1988, No. 1657* (1988)
- 4 WILSON, S. and HEDGE A., *A Study of Building Sickness*, Building Use Studies Ltd, London (1987)
- 5 WILSON, S., O'SULLIVAN, P., JONES, P. and HEDGE, A., *Sick Building Syndrome and Environmental Conditions*, Building Use Studies Ltd, London (1987)
- 6 RAW, G., *Sick Building Syndrome*. The review of the evidence on causes and solutions. HSE Contract Research Report No. 42/1992
- 7 *CIBSE Guide Book A*, Section A3, CIBSE, London (1986)
- 8 *CIBSE Guide Book A*, Sections A5 and A9, CIBSE, London (1986)
- 9 *Fuel Economy Handbook*, National Industrial Fuel Efficiency Service, Graham and Trotman, London (1980)
- 10 *Applied Air Conditioning and Refrigeration*, 2nd edition, G. T. Gosling, Applied Science
- 11 *Controls for Domestic Central Heating Systems*, British Gas (October 1978)

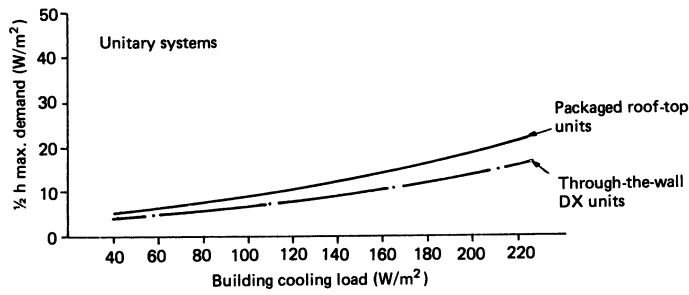
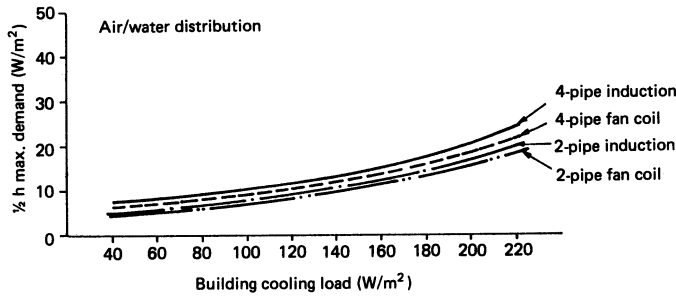
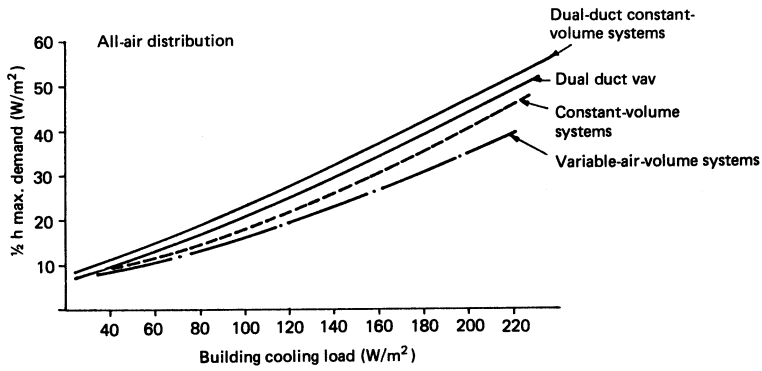

Figure 22.34 Maximum electrical demand for fans and pumps. VAV = variable air volume; DX = direct expansion. (Courtesy of Ove Arup Partnership)

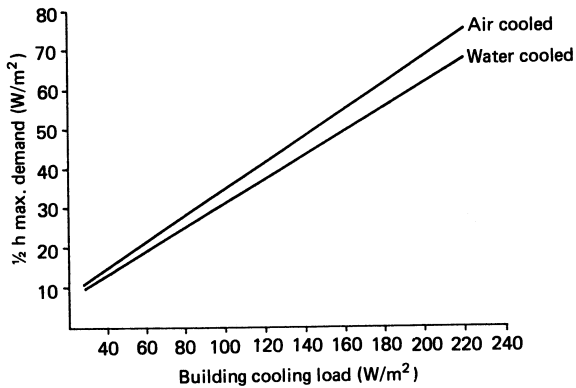

Figure 22.35 Full-load maximum demand characteristics for water- and air-cooled chillers. (Courtesy of Ove Arup Partnership)

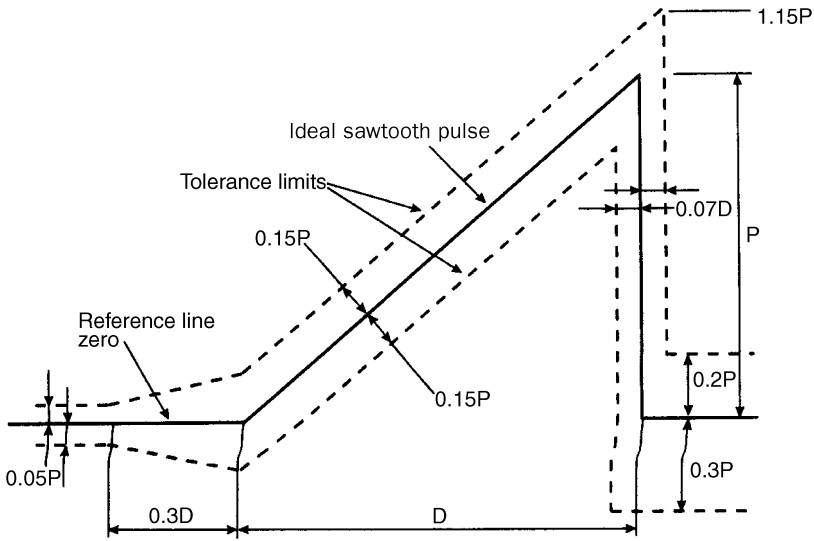

Figure 22.36 Shock pulse configuration and its tolerance limits (courtesy of Ove Arup Partnership)

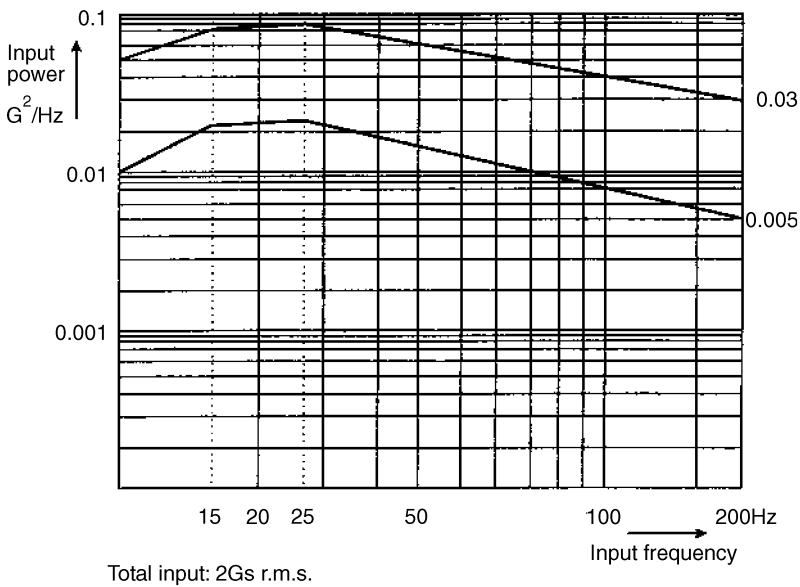

Figure 22.37 Power spectral density graph for random vibration testing