

9

Electroheat and Materials Processing

P L Jones PhD, CEng, MIMechE
Petrie Technologies Ltd, Chorley, Lancs
(Sections 9.1 to 9.9)

S Taylor BSc, PhD, MEng, ACGI, CEng, MIEE
University of Liverpool
(Section 9.10)

S Nakai
Institute of Laser Engineering, Osaka University
(Section 9.11)

J Jennings

Contents

- 9.1 Introduction 9/3
- 9.2 Direct resistance heating 9/3
 - 9.2.1 Metals 9/3
 - 9.2.2 Glass 9/4
 - 9.2.3 Water 9/4
 - 9.2.4 Salt baths 9/4
 - 9.2.5 Other fluids 9/4
- 9.3 Indirect resistance heating 9/5
 - 9.3.1 Metallic elements 9/5
 - 9.3.2 Sheathed elements 9/5
 - 9.3.3 Ceramic elements 9/5
 - 9.3.4 Terminals and leads 9/5
 - 9.3.5 Aggressive environments 9/6
 - 9.3.6 Infra-red heaters 9/8
- 9.4 Electric ovens and furnaces 9/9
 - 9.4.1 Heating-element construction for ovens and furnaces 9/9
 - 9.4.2 Ovens 9/9
 - 9.4.3 Furnaces 9/10
- 9.5 Induction heating 9/10
 - 9.5.1 Power sources for induction heating 9/12
 - 9.5.2 Load matching 9/13
 - 9.5.3 Coil design 9/13
 - 9.5.4 Through heating of billets and slabs 9/14
 - 9.5.5 Strip heating 9/14
 - 9.5.6 Surface and localised heating 9/14
 - 9.5.7 Semiconductor manufacture 9/14
 - 9.5.8 Indirect induction heating for non-metals 9/14
- 9.6 Metal melting 9/15
 - 9.6.1 Introduction 9/15
 - 9.6.2 Arc furnace 9/16
 - 9.6.3 Coreless induction furnace 9/17
 - 9.6.4 Channel induction furnace 9/19
 - 9.6.5 Resistance furnaces 9/20
- 9.7 Dielectric heating 9/20
 - 9.7.1 RF dielectric heating systems 9/21
 - 9.7.2 Microwave power sources and applicators 9/23
- 9.8 Ultraviolet processes 9/24
- 9.9 Plasma torches 9/24
 - 9.9.1 Types of plasma-torch design 9/24
 - 9.9.2 Electrical connection of plasma torches 9/25
 - 9.9.3 Performance 9/25
 - 9.9.4 Plasma furnaces or reactors 9/26
- 9.10 Semiconductor plasma processing 9/26
 - 9.10.1 Basic mechanisms in plasma processing 9/27
 - 9.10.2 Power supplies for plasma production 9/29
 - 9.10.3 Current trends and future developments 9/30
- 9.11 Lasers 9/30
 - 9.11.1 Introduction 9/30
 - 9.11.2 Gas lasers 9/32
 - 9.11.3 Solid-state lasers 9/32
 - 9.11.4 Application of high-power lasers 9/34
 - 9.11.5 Laser pumping methods and electric power supplies 9/37

9.1 Introduction

The three major uses of electricity in industry are motive power, lighting and in the provision of heat for processes. The latter is perhaps the most interesting since it covers such a wide variety of products ranging from metals, glasses and ceramics to textiles, paper, food and drink. The processes covered involve aspects of the whole frequency range from d.c. to ultraviolet and power levels from a few watts to many megawatts (Table 9.1). With the changes away from 'smoke stack' industries some electroheat processes have decreased in importance but others involved in the newer higher value operations are widely accepted.

9.2 Direct resistance heating

Direct resistance heating is used in the iron and steel industry: for heating rods and billets prior to rolling and forging; for ferrous and non-ferrous annealing; either alone or in combination with other fuels for melting glass; in electrode boilers, for water heating and steam raising; and in salt baths, for the surface heat treatment of metallic components.

9.2.1 Metals

The resistivity of several common materials is shown in Table 9.2, and Figure 9.1 shows the variation in resistivity with temperature of some of these. The relatively high resistivity of steel allows billets of up to 200 m² to be heated efficiently, provided that the length is several times greater than the diameter. The heating time is of the order of seconds to a few minutes, so that heat losses (e.g. radiation from the surface and thermal conduction through the contacts) are small. The efficiency of the process can be of the order of 90% or better. The workpiece resistance is normally low, and for these efficiencies to be achieved the supply resistance must be much lower. The low resistivity of copper and similar materials implies that the length/diameter ratio should be considerably higher than 6 if the process is to be successful, and with these materials the more common application is the annealing of wire and strip. In all cases the cross-sectional area of the current-flow path must be uniform, otherwise excessive heating, with the possibility of melting, will occur at the narrower sections. With the normal 50-Hz supplies non-uniform current distribution caused by skin effect leads to higher heating rates at the surface, but this is counteracted by increased surface heat loss.

Table 9.1 Electric heating processes

Technique	Frequency range	Power range
Direct resistance	0–50 Hz	0.01–30 MW
Indirect resistance	50 Hz	0.5–5 kW
Oven, furnace	50 Hz	0.01–1 MW
Arc melting	50 Hz	1–100 MW
Induction heating	50 Hz–450 kHz	0.02–10 MW
Dielectric heating	1–100 MHz	1–5000 kW
Microwave heating	0.5–25 GHz	1–100 kW
Plasma torch	4 MHz	0.001–1 MW
Laser CO ₂	30 THz	0.1–60 kW
Infra-red	30–400 THz	1–5000 kW
Ultraviolet (mercury arc)	750–1500 THz	1 kW

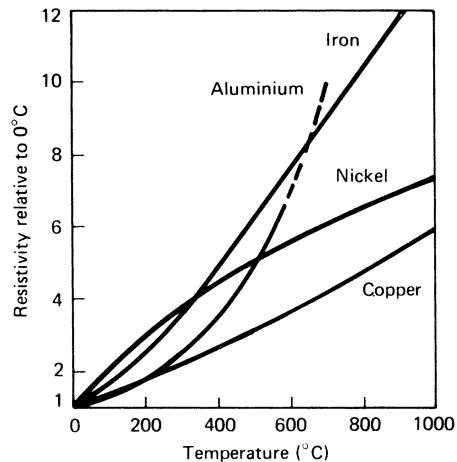

Figure 9.1 Variation of resistivity with temperature (relative to 0°C) of aluminium, copper, nickel and iron

Table 9.2 Resistivity of typical metals

Metal	Resistivity ($\mu\Omega\text{-cm}$)
Copper	1.6
Aluminium	2.5
Nickel	6.1
Iron	8.9
Mild steel	16.0
Stainless steel	69.0

A typical supply circuit is shown in Figure 9.2. The high-current transformer will usually have off-load tappings to take account of the major changes in workpiece resistivity that occur over the heating cycle. The reactance of this transformer and its associated connections should be minimised and the whole arrangement must be designed to withstand the magnetic forces at the high currents involved which, in the larger units, can be in excess of 100 kA. Although this is a resistance-heating application, the inductance of the circuit may result in a power factor as low as 0.4 at the start of the process, and power-factor-correction capacitors are often incorporated.

A high contact resistance between the supply and the workpiece leads to excessive voltage drop and local overheating. Large-volume contacts behave as heat sinks when

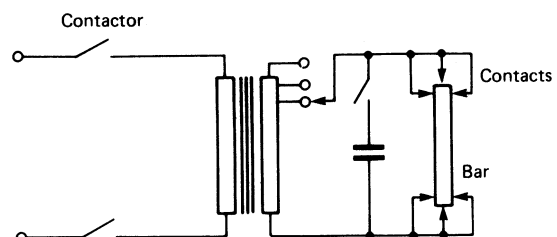

Figure 9.2 Electric circuit for direct resistance billet heater

the possibility of cold ends, and welding of the contact to the bar may occur. Allowance needs to be made for the longitudinal thermal expansion during heating. One commercial arrangement uses a number of hemispherical contacts of copper alloy at each end of the bar, applied by hydraulic pressure. Liquid contacts have been employed for the continuous heating of wire and strip. Sliding or rolling metal-metal contacts are also used.

Process control can be achieved on the basis of a simple timed cycle with the transformer tapings adjusted during the cycle to maintain the required current. A refinement involves weighing the billet before the process is started and using this information to adjust the cycle time to give the required temperature. Other installations are controlled by an optical pyrometer to monitor the surface temperature and feed back a signal to the control system. Wire and strip heating installations usually employ throughput speed as the control variable.

The direct resistance heating of bar or billets is a one-phase load that is switched at frequent intervals. This results in voltage unbalance at the point of common coupling and in transient voltage disturbances. The load can be phase balanced by inductive and capacitive components. In large units the switch-on disturbances may be compensated by a soft-start arrangement.

9.2.2 Glass

Glass at temperatures above 1100°C , has low viscosity and a resistivity low enough (*Figure 9.3*) for direct resistance heating at acceptable voltages to be considered.

In the UK, electricity is used in mixed melting units where, typically, electrodes are added to a fuel furnace to increase the output for a relatively low capital outlay. Current is passed between electrodes immersed in the molten glass. These electrodes must withstand the high temperatures involved and the movement of molten glass across their surface, and must be protected from exposure to the atmosphere. Contamination of the glass by pick up of electrode material must also be avoided and either molybdenum or tin oxide electrodes are used with current densities of the order of 1.5 kA/m^2 . A one-, two- or three-phase electrode system may be employed; the two-phase connection uses Scott-connected transformers. The three-phase arrangement is preferred for phase balance and low cost, and also produces electromagnetic forces in the glass which, together with the thermal forces, lead to significant movement in the melt. Provided that it is not excessive, the movement improves quality and melting rate.

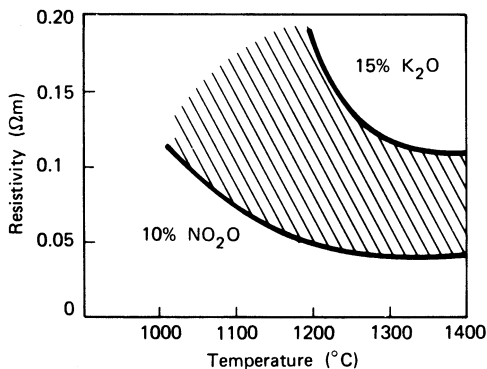

Figure 9.3 Variation of resistivity with temperature of glasses

Existing electric furnaces have usually followed a traditional design pattern with a rectangular tank, but circular designs have now been developed which are claimed to give improved stirring in the melting zone.

The power input to the furnace, and hence the melting rate, is controlled by varying the input voltage by use of tapped transformers or saturable inductors. An alternative method is to change the effective surface area of the electrodes by raising them from the melt.

9.2.3 Water

The generation of steam and hot water by passing current between electrodes in water is now common practice. As with molten glass, the conductivity is dependent on the ions that the water contains, but in many districts it is sufficient to use normal tap water. Electrode boilers range in size from a few kilowatts up to 20 MW. The larger capacity units operate at high voltages up to 6 kV, and the water is sprayed on to the cast-iron electrode. The heating rate is regulated by moving a porcelain shield over the jets to divert the water. Output control in the smaller units is achieved by varying the surface area of the electrode in contact with the water, either by vertical movement of the electrodes or, more simply, by changing the water level in the boiler. It is important to ensure that the conductivity of the water is maintained at the appropriate value: too low a conductivity reduces the power, while if the resistivity is too high the result is a deposition of insoluble salts on the electrodes. In large units the conductivity and pH are continuously monitored and their values automatically controlled.

9.2.4 Salt baths

Salt baths can be used for heat treatment of metal components. The heated salt reacts chemically with the surface layer of the workpiece to give the required surface properties. At temperatures above about 800°C direct resistance heating as opposed to the use of sheathed elements or external heat sources is the only usable method. Although the salt is a good conductor when molten, the bath must be started up from cold by using an auxiliary starting electrode to draw a localised arc. The electrodes have to withstand the corrosive effects of the salt and are manufactured from graphite or a corrosion-resistant steel alloy. The currents involved can be up to 3 kA at voltages of 30 V. Both one- and three-phase units are available.

9.2.5 Other fluids

In recent years the principles of electrode boilers have been extended to the heating of a number of other fluids, under the generic term of *ohmic heating*. Units having a heating capacity of up to 200 kW operating at voltages up to 3.3 kV have been used to heat foodstuffs containing solid particulates (with characteristic dimensions of up to 25 mm) to temperatures of 140°C , thus cooking and sterilising the foodstuff in a single very rapid (in some instances a few tens of seconds) operation, which preserves the quality and taste of the food for subsequent packaging and unrefrigerated storage with a shelf-life of many months.

The potential of the technique for heating other fluids which tend to foul conventional heat-transfer systems, but without the expense of microwave or r.f. generators, has also been exploited in the heating of clarified sewage and sewage sludge to maintain process temperatures during the treatment at sewage works, and as a possible method of pasteurising the final effluent from the works.

The technique also lends itself to the heating of highly corrosive conducting liquids, provided materials can be identified for the electrodes and heater enclosure which are capable of withstanding the conditions in the heater for reasonable periods of time, without introducing unacceptable levels of contamination into the liquid stream.

9.3 Indirect resistance heating

In this method, electricity is passed through a suitable conducting material or element which then transfers its heat by conduction, convection and/or radiation to the target material or process. The element becomes the hottest component of the system and the factors which determine the choice of element materials depend on the nature of the heat transfer process employed and the physical and chemical characteristics of the process environment.

All such elements have the following characteristics:

- (1) they are electrically conducting materials;
- (2) they are supplied with electricity via a suitable contact, cold end or terminal block, and leads;
- (3) they need mechanical support;
- (4) they are solid materials; and
- (5) they have properties enabling an economic operating life for the environment or process chosen.

9.3.1 Metallic elements

Traditionally, metallic elements take the form of wire, strip or tape. This calls for reasonable ductility in the manufacturing process. For a given operating temperature, the element life tends to decrease with decreasing cross-section of element caused by progressive oxidation of the surface or reduction in mechanical strength and so, in practice, an optimum element thickness for economic life exists for each application. The choice of metal composition will depend upon the operating temperature required, the material resistivity, the temperature coefficient of resistance, high temperature corrosion resistance, mechanical strength, formability, and cost. Metallic elements can be manufactured to close tolerances and, provided the material is in the fully annealed, slowly cooled condition, will have nominal resistivities within $\pm 5\%$.

Whilst many metals and alloys are used as element materials, the most common for industrial applications are alloys based on nickel–chromium, iron–nickel–chromium alloys, or iron–chromium–aluminium alloys. All depend on an adherent non-spalling, self-sealing oxide layer forming on the surface of the alloy. Further oxidation is limited by diffusion of reacting species through this oxide layer. The iron–chromium–aluminium alloys rely on an alumina film developing on the surface, whereas the nickel–iron–chromium alloys depend on chromium oxide. Generally, the iron–chromium–aluminium alloys can operate at higher temperatures than the nickel–chromium based alloys, but are not as readily fabricated. The most exotic metals (platinum, tantalum, molybdenum, etc.) are used for special laboratory or high temperature vacuum work. *Table 9.3* summarises some of the characteristics of these materials.

When used in a freely radiating state, the elements need to be supported on ceramic tubes, pins or correctly insulated metallic pins. If ceramic supports are chosen, it is important that they have sufficient mechanical strength to prevent sagging and have a sufficiently high electrical resistance at the working temperature to prevent excessive leakage current. Elements can also be supported in grooves in bricks, partially or fully embedded in ceramic fibre vacuum formed blocks or

cast refractory blocks. It is important to reduce the furnace wall loadings to suitable levels when employing these techniques, and that the electrical loadings, often quoted in terms of watts per square centimetre of element surface, and the geometry of the element and supports comply with the element manufacturer's recommendations.

Advice and literature on this subject is readily available from suppliers.

9.3.2 Sheathed elements

The elements may be protected from the working environment by the use of a suitable insulation layer separating the element from an outer sheath. In many domestic appliances, for example cooker rings, immersion heaters and kettle elements, a purified magnesium oxide powder separates the helical element coils from copper, stainless steel or nickel based alloy sheath material. In these cases the element is often rated in terms of watts per square centimetre of sheath. Such mineral insulated elements are also used in industrial applications as cartridge heaters, radiant panels and immersion heaters.

Thin strip or band heaters are available which use a mica insulation between the element and the sheath.

Higher rated industrial units employ a protective metallic or thermally conducting ceramic sheath insulated from the elements by an air gap created by suitable ceramic supports and spacers. As before, careful consideration should be given to selection of materials for use in each application regarding the heat transfer, electrical and mechanical properties and corrosion characteristics.

9.3.3 Ceramic elements

Silicon carbide, molybdenum disilicide, lanthanum chromite and hot zirconia are examples of ceramic materials which have sufficient electrical conductivity to act as element materials. The silicon carbide and molybdenum disilicide elements depend on a protective, self-sealing silica layer on the surface. These materials tend to be brittle and have to be handled with care, but they can achieve much higher temperatures and surface loadings in air than can conventional metal elements. They also can have unusual temperature coefficients of resistance as shown in *Figure 9.4*. Note that the values shown in this figure are for illustrative purposes only. The actual resistivity will depend on purity, grain size and method of manufacture. Careful selection of element size, shape and working resistance is required in practice, and advice regarding the choice of element, support, insulation and electrical supply characteristics should be sought.

Graphite is another recognised non-metallic element material which, of course, should be operated in the absence of oxygen or gaseous oxygen compounds such as steam and carbon dioxide.

Ceramic elements generally consist of a hot zone either created by a thin section or a spiral cut supported by two or more cold ends which are either thicker in cross-section or which have been impregnated with a metallic phase to lower the resistance locally. Examples, together with their metallic counterparts, are shown in *Figure 9.5*. Ceramic elements must be free to expand and contract in their support system, otherwise tensile failure may occur.

9.3.4 Terminals and leads

The means of connecting the elements to the electrical supply is a very important design requirement and the correct choice of location, materials and joining method can

Table 9.3 Materials for resistance-heating elements*

<i>Material</i>	$\theta_s(^{\circ}\text{C})$	$\rho_s(10^{-8}/\text{m})$	$\alpha_s(10^{-3}/\text{K})$	<i>Principal applications</i>
<i>Nickel based alloys</i> † 80 Ni/20 Cr	1200	108	+14	Furnaces, resistance heaters, mineral insulated elements for domestic and industrial use
60 Ni/15 Cr/bal Fe	1150	111	+18	Firebar and convector heaters. Domestic and furnace applications up to 1100°C
35 Ni/20 Cr/bal Fe	1100	104	+29	Some domestic appliances and general heating equipment at moderate temperatures
20 Ni/25 Cr/bal Fe	1050	95	—	Terminal blocks
<i>Iron based alloys</i> † 22 Cr/5.8 Al/bal Fe	1400	145	+3.2	Furnaces for heat treating glass, ceramics, steel, electronics; crucible furnaces for melting/holding aluminium and zinc
22 Cr/5.3 Al/bal Fe	1375	139	—	Industrial furnaces
22 Cr/4.8 Al/bal Fe	1300	135	4.7	Furnaces for moderate temperatures, appliances
<i>Exotic metals</i>				
Platinum	1300	10.58	3.92	Laboratory furnaces, small muffle furnaces
90 Pt/10 Rh	1550	18.7	—	
60 Pt/40 Rh	1800	17.4	—	
Molybdenum‡←	1750	5.7	4.35	Vacuum furnaces, inert atmosphere furnaces
Tantalum‡←	2500	13.5	3.5	Vacuum furnaces
Tungsten‡←	1800	5.4	4.8	Incandescent lamps, vacuum and inert atmosphere furnaces
<i>Non-metallic materials</i>				
Graphite‡←	3000	1000	-26.6	Vacuum, inert gas, reducing-atmosphere furnaces
Molybdenum disilicide	1900	40	1200	Glass industry, ceramic kilns, metal heat treatment, plus laboratory furnaces
Silicon carbide	1650	1.1×40^5	—	Furnaces for heat treatment of meals, ceramic kilns, conveyor furnaces
Lanthanum chromite	1800	2100	—	Laboratory furnaces and special ceramic kilns
Zirconia§	2200	—	—	Laboratory furnaces and special ceramic kilns

* θ_s , Maximum element operating temperature; ρ_s , electrical resistivity at 20°C; α_s , mean temperature coefficient of resistance at 20°C.

† Approximate compositions.

‡ Not to be used in atmospheres containing oxygen, oxides of carbon, water vapour, etc.

§ Becomes sufficiently conducting at temperatures in excess of 1000°C.

maximise reliability. The temperature of the joint should be kept as low as possible. This can be achieved by using large terminations of high thermal conductivity arranged such that the contact resistance is low and any heat generated in this region can be dissipated correctly. Materials with a good electrical conductivity and high oxidation resistance at the expected temperature are recommended. Several types of nickel alloy can be employed for high-temperature connections, and aluminium braid, held in place with special clips, is used to connect to the cold ends of ceramic elements.

For terminals exposed to wet conditions it is important to ensure adequate corrosion resistance and this should include consideration of avoiding electrochemical corrosion couples by choice of incompatible alloys as well as the danger of electrical shorting across the terminals themselves.

Leads should be of low resistance and should have sufficient section to dissipate any joule heating (I^2R) incurred.

Note that the use of thyristor-control systems may require the use of leads and cables up-rated to cater for harmonic currents.

9.3.5 Aggressive environments

Carbon and sulphur are harmful to nickel based alloys, and chlorine or molten chloride or liquid metal splashes can damage both nickel and iron–chromium–aluminium based alloys. Element materials which rely on a self-sealing oxide for protection may be damaged by reducing atmospheres and the maximum operating temperature of the elements for such conditions, or the element surface electrical load (W/cm^2), may be reduced accordingly. Protective tubes or sheaths may be used for such environments. However, this may impose an additional space requirement in the process and should be considered during the design stage.

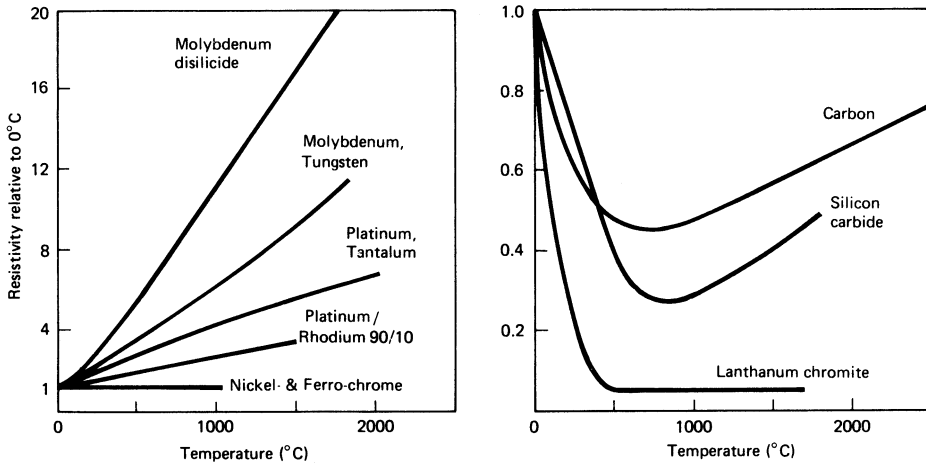

Figure 9.4 Resistivity (relative to 0°C) of some resistance materials

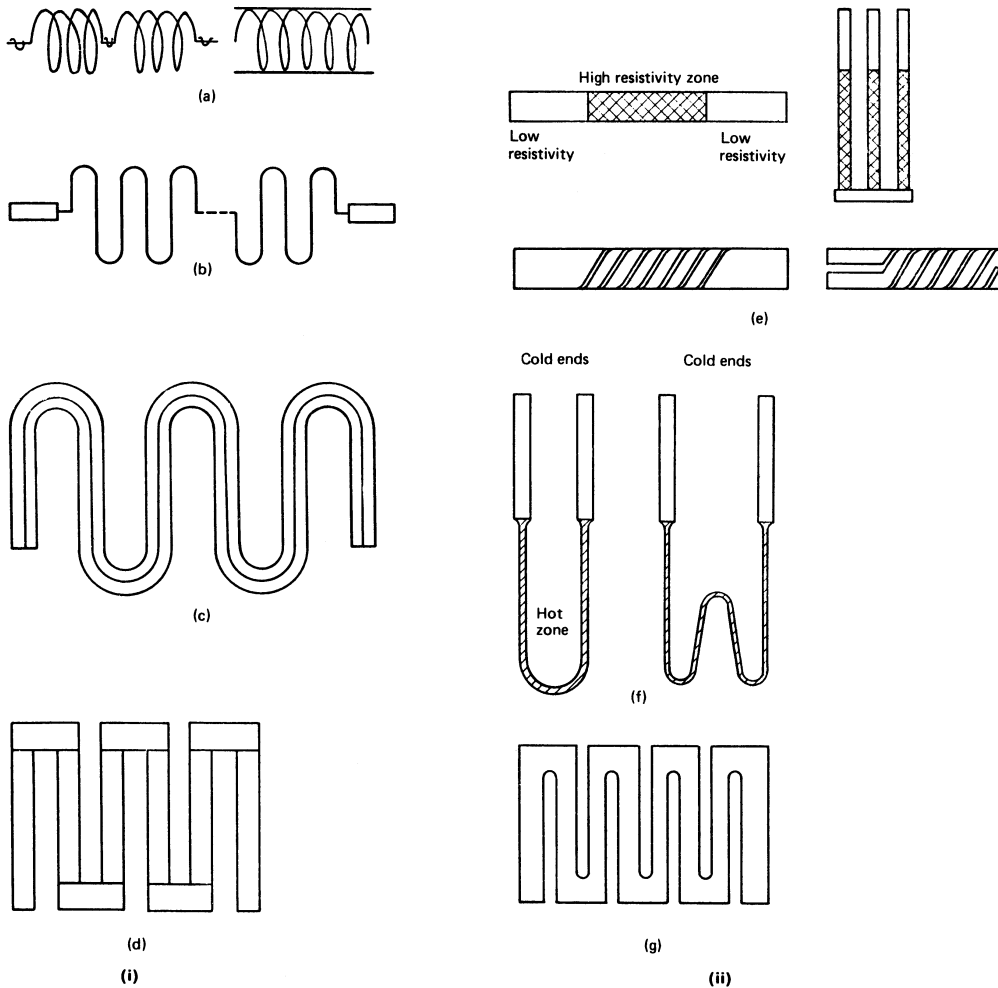

Figure 9.5 Construction of heating elements used in ovens and furnaces: (i) metal heating elements; (a) wire coil supported on hooks or in grooved tile; (b) strip; (c) cast element; (d) tubular heating elements; (ii) non-metallic heating elements; (e) rod and tubular silicon carbide elements; (f) molybdenum disilicide; (g) graphite

Table 9.4 Examples of immersion-heater sheath materials

Iron, steel	Type 20 stainless steel
Grey cast iron	Incoloy 800*
Ni resist cast iron	Inconel 600*
Aluminium	Titanium
Copper	Hastelloy B†
Lead	Quartz
Monel 400*	Graphite
Nickel 200*	Teflon
304, 321, 347 stainless steel	Nitride bonded silicon carbide
316 stainless steel	Silicon carbide

*Registered tradenames of Inco Europe Ltd.

†Registered tradename of Cabot Corporation.

Immersion heater sheath materials should be matched to the process environment too. *Table 9.4* lists some of the materials commonly used for this purpose.

9.3.6 Infra-red heaters

Infra-red is one of the most widely used electrical process heating techniques in industry, finding applications in all sectors. The intensity distribution of radiation with wavelength from an infra-red source varies with its temperature. Proportionately more of the power is radiated at shorter wavelengths as the temperature of the source is increased (*Figure 9.6*). Typical input power densities to different types of infra-red sources are given in *Table 9.5*, with many

of the comments given earlier in Section 9.3 applying also to their use for infra-red heating. The lower temperature infra-red sources (long and medium wave) are normally used for heating and drying non-metallic materials as these generally absorb at the longer wavelengths. Short-wave heaters are used where higher product temperatures are required (e.g. metal heat treatment), high intensities and through heating of suitable materials.

Efficient use of infra-red radiation for heating is assisted by matching the spectral output of the infra-red source to the reflective and absorptive properties of the product in the infra-red range. Materials considered to be good absorbers of infra-red radiation, because they are opaque, can show a significant degree of reflection, particularly at short wavelengths. Materials of thick section which show a considerable degree of transparency to some infra-red wavelengths, can advantageously be through heated by choosing an infra-red source producing most of its output at these wavelengths.

Control of infra-red heating can be effected in a number of ways. Infra-red heaters are generally of low power rating (less than 10kW). Thus an infra-red heating installation will often use many heaters which can either be switched on/off individually or in groups, or the voltage/current to each or groups can be adjusted. As control of heating systems increases, contact or remote (pyrometers) temperature sensing of the product is used, with information fed back to the control system for the heaters. One aspect of altering the power input to an infra-red heater is that its temperature, and hence its spectral output, will be changed which can have implications for the efficient heating of those materials which show a variation in infra-red absorption with wavelength.

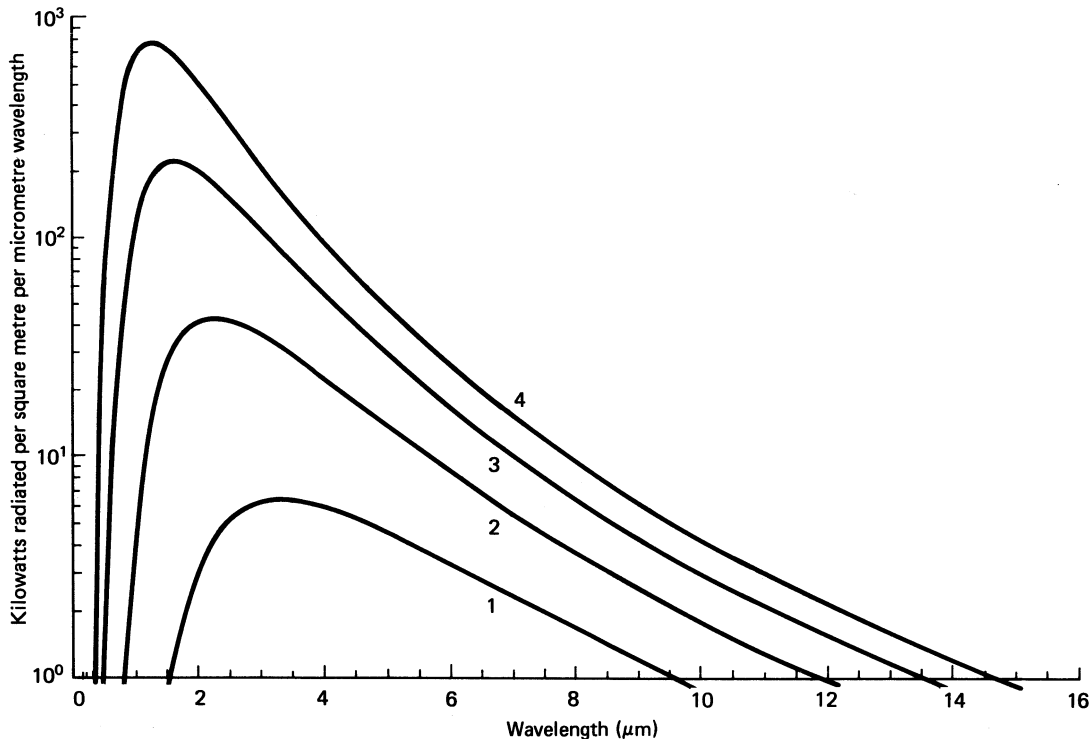

Figure 9.6 Black-body radiation: 1, 600°C; 2, 1000°C; 3, 1500°C; 4, 2000°C

Table 9.5 Characteristics of infra-red heaters

Type	Maximum surface temperature (°C)	Maximum power density (kW/m ²)	Heater wavelength
Embedded ceramic heater	600	68*	Long
Mineral insulated element	800	40*	Long
Tubular quartz-sheathed element	900	50*	Medium
Circular heat lamp (375 W)	2100	30*	Short
Linear heat lamp (1 kW)			
Parabolic reflector	2100	50*	Short
Elliptical reflector	2100	90†←	
Quartz-halogen linear heat lamp (12 kW)			
Parabolic reflector	2700	200*	Short
Elliptical reflector	2700	3000†←	Short

* Average power density.

† Power density at focus.

9.4 Electric ovens and furnaces

Electric ovens and furnaces are used for a great variety of different processes, ranging from sintering ceramic materials at temperatures up to 1800°C to drying processes close to ambient temperature at power ratings varying from a few kilowatts to more than 1 MW. A substantial part of the electric heating load is taken by electric ovens and furnaces of conventional design used for heat treatment (*Table 9.6*) and similar processes at temperatures up to about 1100°C.

9.4.1 Heating-element construction for ovens and furnaces

The materials used for resistance heating elements have been listed in *Table 9.3*. Forms of construction of furnace heating

elements are shown in *Figure 9.5*. Metal resistance heating elements for furnaces are normally in the form of wire, strip or tube. Heavy-section low-voltage high-current elements are made with an alloy casting or with corrugated or welded tube. Helically wound wire heating elements are manufactured with wire-to-mandrel diameter ratios of between 3:1 and 8:1, limited by collapse of the helix. The helix is then expanded so that its length is about three times the close-wound length. Coiled-wire or strip heating elements may be inserted in ledges or grooves supported at intervals by nickel alloy or ceramic pegs. The end connections of the heating elements, normally made of a material different from that of the element to reduce attack from oxidation and chemical reaction with the refractories, have a lower resistance to reduce heat dissipation where the leads pass through the furnace wall; this lower resistance is achieved by making the diameter of the ends greater than that of the heating zone or by using a material of high electrical conductivity.

Silicon carbide rod or tubular heating elements are mounted vertically at the side or arranged to span the roof of the furnace. The cold ends of these rod elements are impregnated with silicon or made by joining end sections of higher conductivity. The hot zone of a tubular element is obtained by cutting a helix so that the current path length is increased and the cross-section is reduced which increases the resistance. Single-ended double-spiral and three-phase rod heaters can be suspended vertically from the roof of the furnace.

Molybdenum disilicide is normally available only in the hairpin or W-form of construction for suspending vertically or supporting in a horizontal plane. The heating zone is of reduced cross-section to increase the resistance. Graphite in the form of machined rods or slabs, or as tubes, is used in muffle furnaces.

9.4.2 Ovens

An oven is usually defined as having an upper temperature limit of about 450°C. Ovens, using natural or forced convection, are widely employed for drying and preheating plastics prior to forming, curing, annealing glass and aluminium baking and a host of other applications. Coiled nickel-chrome wire or mineral-insulated metal sheathed heating elements are distributed around the oven so as to obtain as uniform a temperature distribution as possible. Heat transfer rates may be increased by using a fan to circulate air over the heating elements onto the workpiece, the air being recirculated through ducts. An important advantage of convective ovens is

Table 9.6 Heat-treatment processes

Metal	Treatment process	Temperature range (°C)
Aluminium and alloys	Annealing	250–520
	Forging	350–540
	Solution heat treatment	400–500
	Precipitation hardening	100–200
	Stress relief	100–200
Copper	Annealing	200–500
Brass	Annealing	400–650
Magnesium and alloys	Annealing	180–400
	Solution heat treatment	400
	Precipitation hardening	100–180
Nickel and alloys	Annealing	650–1100
Carbon steel (0.6–1.5% C)	Annealing	720–770
	Forging	800–950
	Tempering	200–300
	Hardening	760–820
Stainless steels	Tempering	175–750
	Hardening	950–1050
Cast iron	Annealing	500

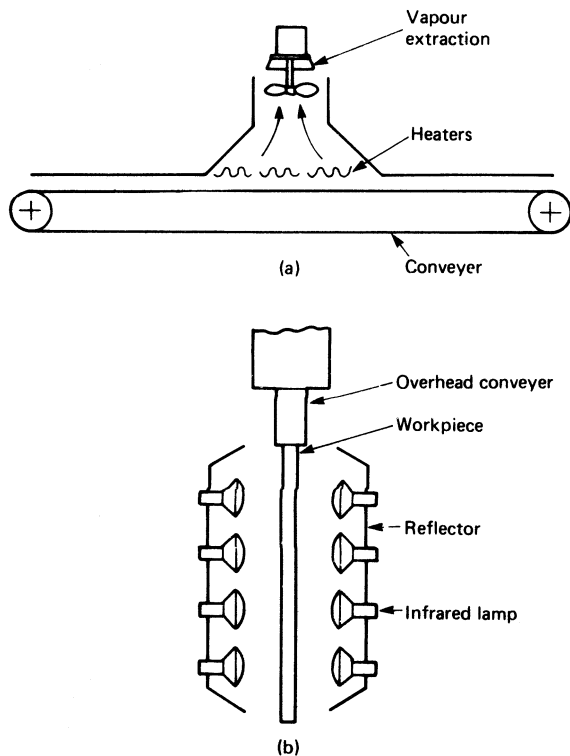

Figure 9.7 Infra-red conveyor ovens. (a) Horizontal conveyor; (b) Vertical conveyor

that the operating temperature is normally the element temperature and the maximum temperature is never exceeded as the process is self-limiting, which prevents overheating if the material is left in the oven too long. This is particularly important for temperature-sensitive materials such as plastics.

High heating rates can be achieved by direct radiation from heating elements in infra-red ovens. The oven walls are made of sheet metal which reflects the radiation, and vapour is easily removed. Two forms of continuous infra-red ovens are illustrated in *Figure 9.7*, the low thermal mass and weight allowing a light-weight structure and a very high power density. The high-intensity lamps employed have a low thermal inertia and can be switched to a low level of stand-by power, full power being used only when the workpiece is inside the oven. Infra-red heating processes are advantageous when only the surface layer is required to be heated, for example when curing coatings, so that the overall efficiency may be very high compared with other methods which heat also the substrate.

9.4.3 Furnaces

Furnace construction depends on the application. Some examples of batch furnaces for heat treatment are shown in *Figure 9.8*. The heating elements are arranged around the sides of the furnace and, where very uniform heating is required, also in the roof, door and hearth. Radiation from the heating elements and from the refractory lining occurs, so that the internal surface of the furnace approximates to a black-body enclosure.

Forms of work handling used with batch furnaces include bogie or car-bottom hearths and elevated hearths raised into the furnace on hydraulic rams to facilitate loading and unloading. The box furnace is normally used at temperatures where radiation is dominant. Where it is necessary to avoid exposure to air during the quenching process, the sealed quench furnace is used. Forced convection furnaces allow high heating rates and with careful design, good temperature uniformity can be achieved; but usually these are limited to maximum temperatures of 700–900°C. In the pit furnace, capable of operating at higher temperatures, radiation is the dominant mode of heat transfer and, by using a retort, the process can be carried out in a controlled atmosphere.

The bell furnace may be used as a hot-retort vacuum furnace. By reducing the pressure inside the bell, very low partial pressures of oxygen are obtained. Since heat losses by convection are greatly reduced at low pressures, the bell can be raised when the required temperature is reached, one bell then being used to heat several retorts.

The rectangular bell furnace is a form of box furnace that allows unimpeded access to the furnace hearth. It is useful for heat treating large components such as mill rolls or fragile items such as ceramics. The cold-retort vacuum furnace allows very high temperatures to be achieved. It is used for heat treatment and brazing in controlled low-pressure atmospheres using vacuum interlocks to achieve high throughputs. The hydrogen muffle furnace is used for sintering alumina at 1700°C, zone refining where a precise temperature profile is required, and the continuous annealing of wire and strip in controlled atmosphere by use of an open-ended muffle.

Continuous furnaces use a conveyor mechanism enabling in-line processes to be carried out combining heating and cooling at a controlled rate (*Figure 9.9*). Some examples of different conveyor mechanisms are illustrated in *Figure 9.10*. The choice depends on the nature of the process and the size of the workpiece. Applications range from bright annealing of fasteners to normalising steel billets.

9.5 Induction heating

Induction heating makes use of the transformer effect. The workpiece is placed in the alternating magnetic field of a coil. The field produces eddy currents in the workpiece, which is heated as a result of I^2R losses. The induced current density and consequent heating effect is always non-uniform; it depends on the magnitude and frequency of the inducing field and the physical properties of the workpiece. The current density in the workpiece is a maximum nearest to the surface adjacent to the coil conductors and, in the case of a solid workpiece in an enclosing coil, is zero at the centre. The distribution of heating in the body of the workpiece can be controlled by choice of frequency. If the frequency is high, most of the heat is developed in a thin layer, while lower frequencies give a more uniform distribution. Hysteresis loss heating also occurs in ferrous metals; it is normally small compared with the eddy-current effect but it is applicable in heating metal powders at high frequencies. Induction techniques are used for both through heating and surface heating of metallic materials at frequencies in the range 50 Hz to 1 MHz. They are used for melting and also, at very high frequencies, in the manufacture of semiconductor materials, and the hot working of glass.

The eddy-current power P per unit length of a cylindrical workpiece of diameter d , resistivity ρ_s and absolute

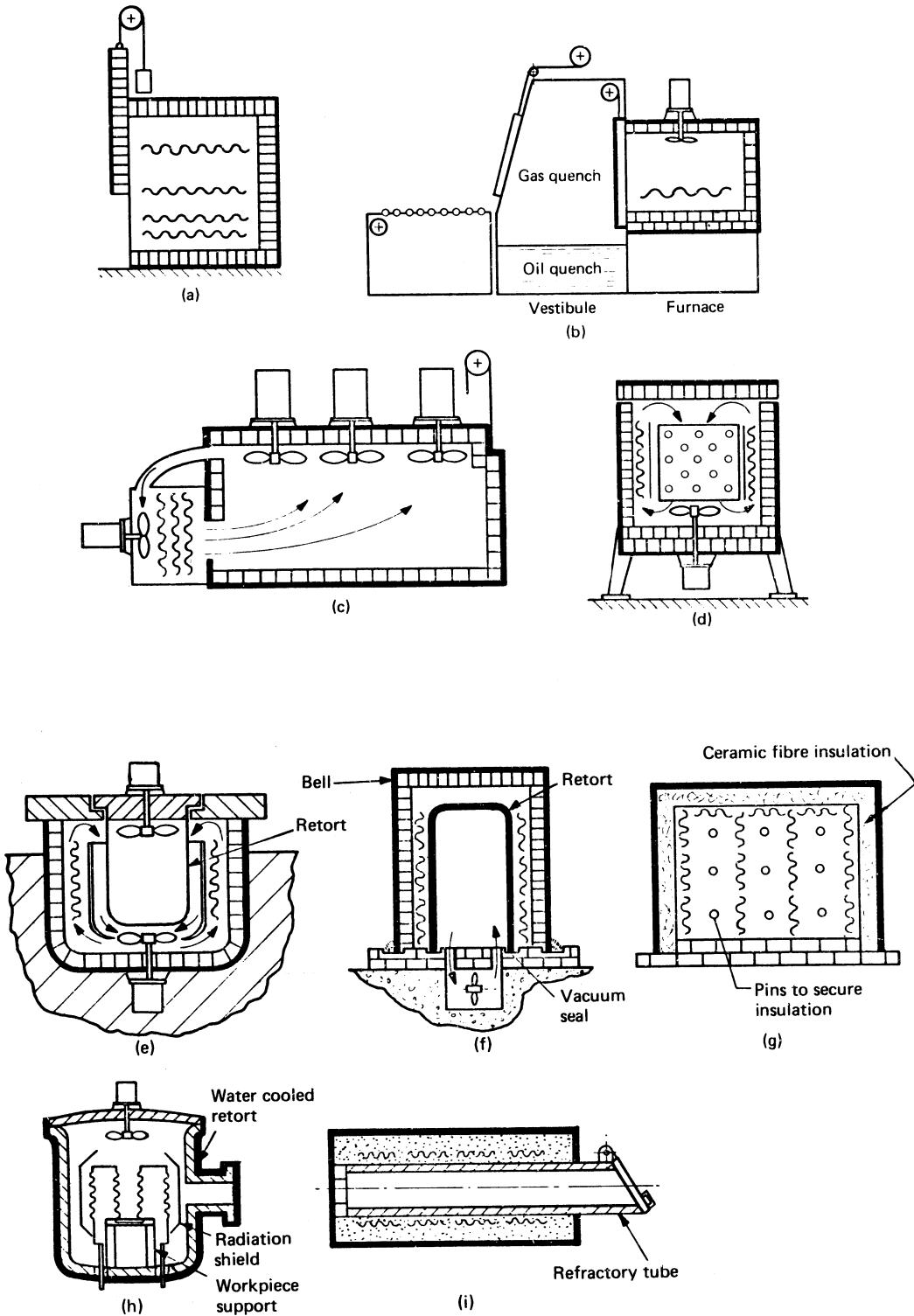

Figure 9.8 Batch furnaces for heat treatment: (a) box furnace; (b) sealed quench furnace; (c) horizontal forced convection furnace; (d) vertical forced convection furnace; (e) pit furnace; (f) bell (hot retort) vacuum furnace; (g) rectangular bell (low thermal mass) furnace; (h) cold retort vacuum furnace; (i) muffle furnace

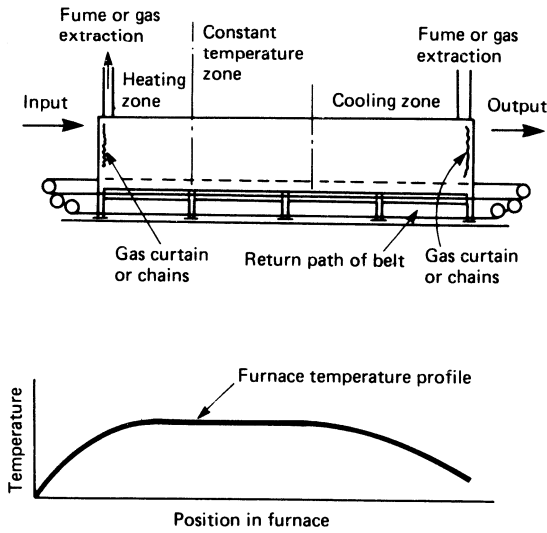

Figure 9.9 Conveyor furnace and typical temperature profile

permeability μ , induced by an alternating field of strength H (r.m.s.) and frequency f is

$$P = H^2 \frac{\pi c}{2} \left(\frac{d}{\delta c} \right)^2 \rho Q \tag{9.1}$$

where δ is the skin depth of the induced current

$$\delta = (\rho / \pi f \mu)^{1/2} \tag{9.2}$$

Q is a factor depending on skin depth and the shape of the workpiece, and is plotted in Figure 9.11 for a cylinder in terms of a normalised (dimension/skin depth) parameter. Values of δ , based on room-temperature resistivities and assuming, where appropriate, a relative permeability of 100 (i.e. $\mu \leq 100 \mu_0$), are given for a number of materials in Table 9.7. The relative permeability is a function of the applied magnetic field strength and can be as low as 10 in high-intensity heating applications. For design purposes, the value of resistivity appropriate to the average temperature of the workpiece is used. High frequencies (i.e. small skin depths) are needed if workpieces of small dimensions are to be heated.

9.5.1 Power sources for induction heating

There is still an economic advantage in being able to use power at the frequency of the mains supply rather than converting to a higher frequency. However, the increased power rating of solid-state converters, their reducing cost/unit power, ease of control and the fact that they present balanced loads to the supply system, means that each application must be carefully assessed. Loads which can be effectively heated at 50 Hz include slabs, large billets and cylinders, and process vessels. Depending on the load rating, the power input is controlled by either an off-load tap changing transformer or an autotransformer. Power-factor correction is usually provided on the primary side of the heater supply transformer, and phase-balancing networks are used to correct the imbalance of large single-phase loads. Voltage transients on the supply network are minimised by the use of soft-start arrangements when switching large loads.

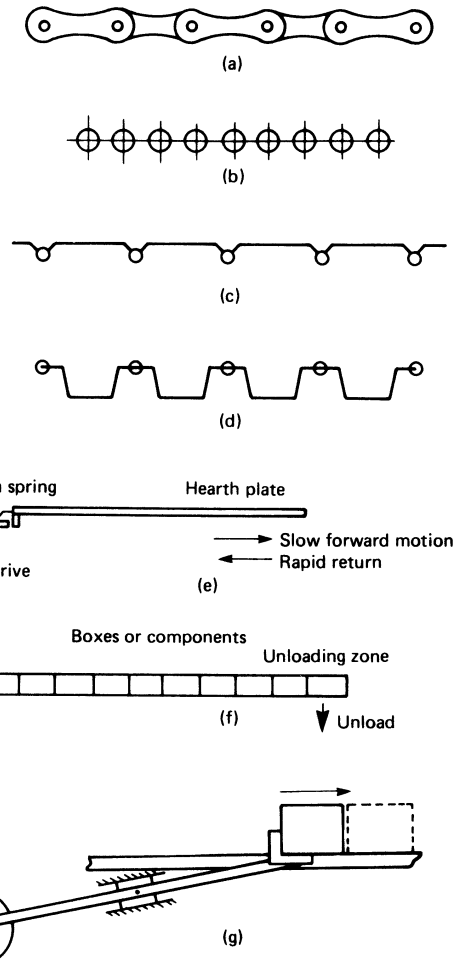

Figure 9.10 Some examples of conveyor furnace mechanisms. (a) Cast link conveyor; (b) Roller hearth; (c) Salt belt conveyor; (d) Slat pan conveyor; (e) Shaker hearth; (f) Pusher furnace mechanism; (g) Walking beam furnace

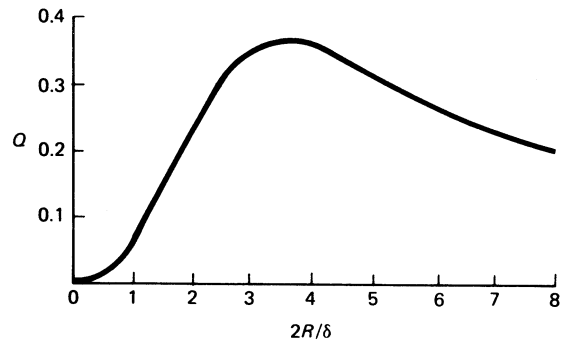

Figure 9.11 Variation of Q with the normalised diameter for a solid cylinder

Table 9.7 Typical skin depth (mm) and frequency relation

Metal*	Frequency				
	50 Hz	150 Hz	1 kHz	10 kHz	450 kHz
Copper	9.3	5.4	2.1	0.66	0.098
Aluminium	11.7	6.8	2.6	0.83	0.12
Grey iron	(a) 6	3.4	1.3	0.42	0.063
	(b) 78	45	18	5.5	0.83
Steel	(a) 2.9	1.6	0.64	0.20	0.03
	(b) 71	41	16	5	0.75
Nickel	(a) 1.9	1.1	0.42	0.13	0.02
	(b) 34	20	7.6	2.4	0.36

* (a) Below Curie temperature ($\mu_r = 400$, $\rho_{\text{sat}} 20^\circ\text{C}$). (b) Above Curie temperature ($\mu_r = 4$, ρ_{sat} Curie temperature).

Power supplies for frequencies above that of the mains supply are now almost invariably based on solid-state converters. Some large installations previously utilised static frequency triplers to provide a 150 Hz supply for through heating slabs prior to rolling, derived from three one-phase saturated transformers with secondaries connected in open delta (Figure 9.12). Harmonics generated in the tripler are filtered by an arrangement of inductors and capacitors. A 20 MW installation of this type is operated in Canada.

Higher frequencies give faster heating rates and, because of skin-effect phenomena, enable the effective induction heating of a smaller cross-section of workpiece. Power at these frequencies, before the advent of the thyristor, was obtained from rotating machines designed to produce power at frequencies up to 10 kHz. They are normally vertically mounted and, in the larger sizes, water cooled. Conventional starting equipment is used for the induction motor. Output power is controlled by varying the d.c. excitation of the alternator field either manually or with an automatic voltage regulator. They have a fixed frequency output and present a balanced load to the supply; the efficiency is comparatively low and falls with decreasing load and increasing frequency. These machines are noisy and were often installed in sound-reducing enclosures.

The availability of high-power thyristors capable of operating at frequencies up to 50 kHz has opened up a new field to the designers of medium-frequency heating equipment. Sources based on these devices are commercially available with power outputs up to about 6 MW at the lower frequencies. The major applications are through heating and melting, and this source has the advantage over the machine of a flexible operating frequency. The efficiency is around 90%,

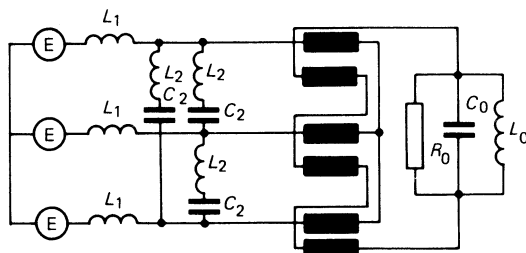
**Figure 9.12** Three-phase transformer with open delta secondary for generation of the third harmonic

even on partial load. The operating principle is familiar: the rectified 50 Hz supply is chopped by thyristors and fed into a resonant load circuit formed by the resistance and inductance of the loaded work coil together with a tuning capacitor. The firing pulses may be applied at a pre-set frequency; alternatively, the control signal may be derived by feedback from the load circuit. Principal variants of this basic arrangement are commonly referred to as *voltage source*, *current source* and *variable mark/space ratio generators*. A fourth variation, the cyclo-converter, converts the 50 Hz supply directly to the higher frequencies without the intermediate d.c. stage.

At frequencies above 50 kHz, the power source uses a vacuum triode feeding into a tank circuit of which the load forms a part (Figure 9.13) either directly or through a coupling transformer. Water-cooled inductors are used in the tank circuit and, in all but the smallest ratings, the valve is also water cooled. Conventional industrial valves have been and still are used for this application in ratings of up to 500 kW operating in the class C mode with conversion efficiencies greater than 50%. Even higher efficiencies are obtained with the magnetically beamed triode, which has an inherent low grid dissipation. This valve is robust and offers more flexible control than the conventional unit, owing to the lower grid power requirements which enable semiconductor control circuits to be used. Closed-loop control of the process variables, i.e. power and temperature, is possible.

An important version of the triode based r.f. generator uses a high efficiency coupling transformer in the triode circuit, with the tuning capacitors connected directly across the work coil. This 'aperiodic' generator can operate over a wide frequency range, supplying remote workstations at a higher efficiency than the more conventional oscillator.

9.5.2 Load matching

The matching of the loaded work coil to the source is extremely important in the successful application of induction heating processes. The impedance of the work coil depends on the geometry and physical properties of the workpiece, the frequency of operation, and the geometry and number of turns of the coil. A matching transformer may be required if the correct impedance cannot be achieved by selection of coil turns. The rating of the power source is minimised by tuning the reactive component of the load impedance with capacitors. These may be connected in series or parallel directly with the load coil, or on the primary side of the matching transformer, depending on the coil voltage and type of power source.

The load impedance will change during a heating cycle which might necessitate re-tuning or re-matching to the source.

9.5.3 Coil design

Coil designs depend on the operating frequency and the application. The basic objectives are to produce the

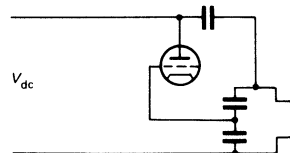
**Figure 9.13** Basic oscillator circuit for r.f. induction heaters

required magnetic field strength over that section of the workpiece to be heated and to insulate the coil both to prevent electrical breakdown and to reduce heat transfer from the workpiece to the coil. The heat generated by the I^2R loss in the coil usually requires some form of forced cooling, and it is customary to use hollow water-cooled copper tubular conductors. The current distribution in the coil conductors is non-uniform. It is frequency dependent, and affected by the proximity of adjacent conductors, the presence of the workpiece and the geometry of the winding.

Although most units employ only one layer of winding, there is now widespread use of multilayer windings for the heating of non-ferrous billets at supply frequency. With the correct choice of conductor cross-section, multilayer coils offer significant energy savings in these applications.

9.5.4 Through heating of billets and slabs

Induction heating is used extensively for the through heating of both ferrous and non-ferrous metal billets prior to rolling or forging. The billets, of circular or rectangular cross-section, are either heated individually or passed in line through a series of induction coils. The frequency of the current, the power input and the length of time in the coil are chosen to give the required throughput rate with an acceptable temperature distribution over the cross-section of the workpiece. A compromise is sought between high heating rates produced by high frequencies, and an acceptable skin depth. A typical example is a 350 kW, 1 kHz unit for heating steel transmission forgings to a temperature of 1150°C; the energy consumption is of the order of 400 kWh/t and the heating time can be less than 5 min. Heaters with power outputs of up to 6 MW are readily available and, although the frequency for most applications is in the range 50 Hz to 3 kHz, higher values (up to 50 kHz) are occasionally employed. The efficiency of the process is a function of the coil design and the coupling between it and the workpiece. In some instances a tapered coil has been used to allow for the changing parameters of the workpiece material as the temperature increases during the process. The workpiece resistivity at the final working temperature may be four or five times that at 20°C and, in the case of ferromagnetic materials, the relative permeability will fail to unity when the Curie temperature is reached.

Metal slabs are also heated by induction processes. One of the largest single installations is in the USA, where a 200 MW, 60 Hz power supply heats large steel slabs prior to rolling, at a maximum rate of 600 t/h. Average energy consumption is reported as 340 kWh/t for a 22 t slab. A more recent installation in Sweden rated at 37 MW heats 15 t slabs, for rolling, at the rate of 85 t/h. Thin slabs, from continuous casting machines or at an intermediate rolling state, are heated at medium frequency.

9.5.5 Strip heating

The heating of continuous-strip materials by the conventional induction method requires the use of frequencies above 10 kHz and efficiencies are low for non-ferrous materials. A preferred technique is the transverse flux method where, for example, efficiencies above 70% can be achieved heating thin aluminium strip at 250 Hz. The strip is passed between two flat inductors comprised of windings in a laminated iron, or ferrite, core which form a series of magnetic poles. The flux passes transversely through the sheet and currents are induced in the plane of the sheet. The winding and pole arrangement must be designed to give uniform heat distribution over the moving strip. Installations rated

at 1.8 and 2.8 MW are operating in Japan and Belgium, respectively, for the heat treatment of aluminium strip.

Development is also being carried out on the travelling-wave induction heater, which utilises a three-phase winding operating at 50 Hz similar in construction to that of a linear motor with the secondary (workpiece) held stationary. Applications of interest are the heating of metal cylinders and tanks; this technique could also be used for the heating of sheets and slabs.

9.5.6 Surface and localised heating

Induction heating at high frequencies (up to 500 kHz) is used extensively in the engineering manufacturing industries for the hardening of bearing surfaces, welding and brazing and similar surface heat treatment processes. The workpiece is placed in a coil (*Figure 9.14*) designed to cover the area to be heated. Heating takes place within a few seconds and, owing to the high frequencies, is confined in the earlier stages to a thin surface layer. The heated area is then cooled rapidly, so that the required surface hardening effect is obtained while still leaving the centre ductile. Contoured shapes can be heated, as can the internal surfaces of tubes, etc., with suitably designed coils. Flat spiral coils are used for the treatment of localised areas in sheet materials. An extension of the application is to soldering and brazing in which case the field distribution is modified by the use of a field intensifier, a suitably shaped piece of magnetic material such as a ferrite core. The technique is also used for seam welding of steel tubes from flat strip, bent into shape and the two edges welded. The field and, therefore, the heat is concentrated at the two surfaces which are to be welded. In this latter application high throughput rates are achieved by using power sources with ratings as high as 1 MW at 450 kHz.

9.5.7 Semiconductor manufacture

Since the energy from the heating coil can be generated in the workpiece without any heat transfer medium, the whole process can be carried out in a vacuum chamber. This is particularly useful in the manufacture of semiconductor materials. In one technique the material is placed in a conducting crucible in the vacuum space and is heated by induction. Semiconductor materials can also be heated directly by induction without the need for the crucible: in this case very high frequencies up to 4 MHz are used.

9.5.8 Indirect induction heating for non-metals

Induction heating is generally used to heat the 'work' directly, that is the induced currents flow in the electrically conducting object being heated. However, there is an important and growing series of applications where induction heating is used to heat a vessel or container from which heat is transferred by conduction to a non-metal product. Some examples include:

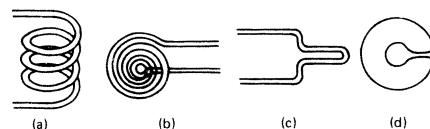

Figure 9.14 Coils for surface hardening by induction heating: (a) cylindrical coil for shaft hardening; (b) pancake coil for heating flat surfaces; (c) hair-pin coil for localised heating; (d) current concentrator

- (1) induction heating of a vessel containing a solid or liquid;
- (2) induction heating of a pipe through which a liquid flows;
- (3) induction heating of a chemical reactor vessel; and
- (4) induction heated extruders.

These techniques often employ the same coil arrangements as have been discussed elsewhere, but there are some recent developments using novel induction techniques.

An example of such a novel technique is ROTEK, a rotary kiln heated by an unusual form of induction heating and used for drying or calcining granular solids which flow continuously through the revolving kiln drum. The kiln lining and agitating/lifting flights are made from stainless steel or Inconel and heated by the passage of a very large electric current flowing from end to end; this current is too large (perhaps 20 kA or more) to be fed through sliding contacts and the drum therefore forms a single-turn secondary of a ring transformer with a bar primary which passes through its centre (see *Figure 9.15*). The bar primary is fed from a low-voltage transformer and the efficiency of the device as a heater is very high. Because the ring core can be thermally insulated, the operating temperature can be well above the Curie point and, with an Inconel drum, temperatures exceeding 1000°C can be achieved.

9.6 Metal melting

9.6.1 Introduction

Before considering the types of electric furnaces used today for melting metals, it is useful to review the options available for converting electrical energy into thermal energy contained within the melt. Essentially two approaches are possible. The most direct approach is to employ Joule heating within the metal to be heated. This approach is used in the coreless induction furnace and the channel induction furnace.

The alternative approach is to convert the electrical energy into a heat flux on the metal surface. This can be done in a number of ways. The thermal energy can be derived from an electric arc (either at the metal surface or sufficiently adjacent to it), from an electric plasma (which may or may not be transferred to the surface of the metal) or from the Joule heating of a resistor adjacent to the metal. The resistor may be molten slag on the metal surface, or a crucible containing the metal, or resistance elements adjacent to the metal or its containment crucible. Electron beam and laser heating techniques are not, as yet, widely used for bulk melting operations, although they are finding increasing application on a small scale, for example in the local melting required for fusion welding.

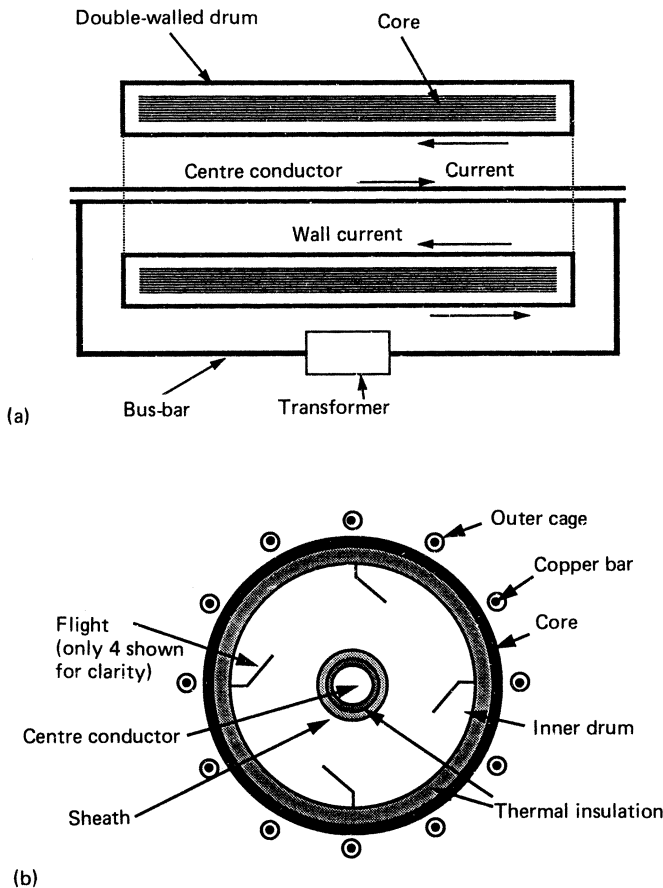

Figure 9.15 ROTEK: (a) operating principle; (b) cross-section of actual machine

In recent years medium frequency coreless induction furnaces have become widely used for a vast number of ferrous and non-ferrous applications. Resistance-heated furnaces have also become firmly established for melting and holding furnaces in the aluminium and zinc casting industries.

9.6.2 Arc furnace

The electric-arc furnace is largely used for the melting of steel scrap to produce liquid steel. Essentially, it consists of a squat cylindrical vessel, refractory lined, with a movable domed refractory roof, as shown in *Figure 9.16*. The furnace is usually charged from a drop bottom bucket. Each of the three graphite electrodes, which pass through holes in the roof, is fed from one phase of the three-phase furnace transformer via flexible cables and bus tubes connecting onto the electrodes. The metal charge forms the star point of the furnace transformer.

Heat-transfer efficiency is high when the arcs are surrounded by solid charge which absorbs the largely radiant energy of the arcs. As the charge melts, the arcs radiate onto the surrounding refractories (which are nowadays largely replaced by water-cooled panels, to reduce overall operating costs), and the thermal efficiency deteriorates because of this. Conversion efficiency of electrical energy into heat in the steel of around 94% is attained.

Electromagnetic stirring may be incorporated by using a non-magnetic steel shell and incorporating a low-frequency stirring coil below the furnace bath. The entire structure, including electrodes, masts, etc., is normally mounted on a hydraulically operated rack and pinion enabling it to be tilted in one direction for pouring and in the reverse direction for slagging. The roof structure is pivoted so that it can be swung aside (with the electrodes raised) for charging. The electrodes can be slipped in the clamp to allow for electrode wear.

The electrode arms can also be raised and lowered individually by hydraulic or winch systems and the electrode height above the melt is controlled by feedback signals derived from the arc voltage and current.

The substation for a large arc furnace is normally adjacent to the furnace itself and contains the furnace transformer, which normally has a star connected primary and an input voltage of 33 kV. The transformer must withstand very large electromechanical forces produced by the high short-circuit currents; it is oil cooled and has terminations brought out to which the flexible cables are connected. The furnace power is

varied by on-load tap-changing. Electrical contact to the electrodes is made by a large copper pad contained in the electrode clamp connected in water-cooled bus-bars which rise and fall with the furnace electrodes. Various configurations have been adopted to ensure that the geometry remains as nearly symmetrical as possible, independent of the bus-bars, to minimise out-of-balance currents. The furnace electrodes are normally connected in delta, and where very high currents are used, the delta is closed at the electrode clamp in order to minimise the effects or reactance in the transformer secondary circuit.

As an electrical load, the arc furnace is less than ideal. The arc can vary between extinction, at zero current, to the short-circuit condition, caused by scrap contacting the electrode. Physical movement of both the solid charge pieces and the melt, when formed, causes variation in the arc length which can fluctuate many times within a second, and superimposed on these effects is arc-length variation caused by the mechanical vibration of the electrode and its supporting structure.

These effects prevent a constant high power level being delivered by each of the phases, and this results in:

- (1) reduced melting rate attained for a given transformer capability;
- (2) the occurrence of current fluctuations which are reflected back into the supply system, these occurring especially in the early stages of the melting operation;
- (3) voltage fluctuations at the point of common coupling to other electricity users; and
- (4) acoustic noise generation from the furnace.

A typical large steelmaking arc furnace is of around 100 t melt capacity and powered at perhaps 50 MVA. No other available electric furnace can match the sort of melting capability attainable from such a single unit, and the furnace, therefore, is likely to remain the only electrical alternative for the tonnages currently required by the steel industry.

9.6.2.1 Submerged-arc process

The submerged-arc process is not essentially an arc process as heating occurs also by direct resistance with, perhaps, some limited heating from arcs and sparks during interruption of the current path. The principal applications are for reducing highly endothermic ferroalloys of high melting point, such as ferromanganese, nickel, chrome, silicon, tungsten and molybdenum, which are subsequently remelted in arc furnaces to produce special alloys. Fused oxides may also be produced via the submerged arc route.

The design of a submerged arc furnace depends on its application. In principle, it is a dish-shaped vessel (*Figure 9.17*),

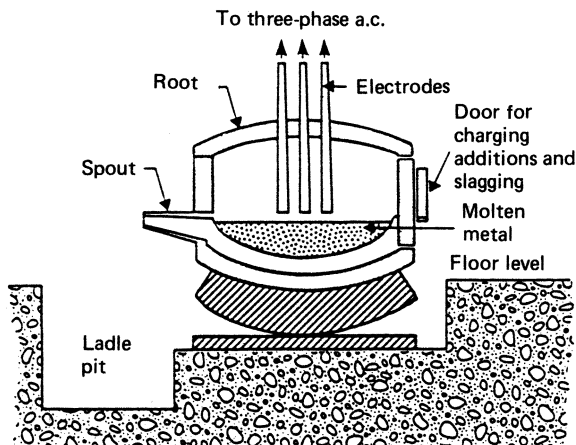

Figure 9.16 Arc furnace

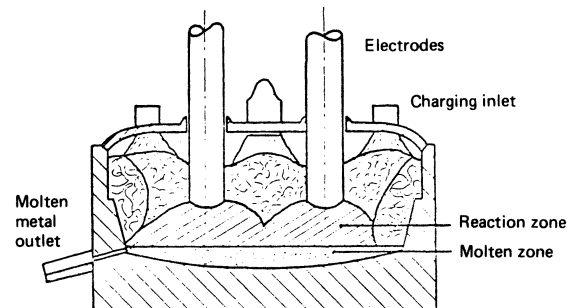

Figure 9.17 Submerged-arc smelting furnace

brick lined, as with the arc furnace. But there the similarity ends: the dish and the roof are axially fixed, although the furnace, together with the electrodes, may rotate. The furnace is charged through ports in the roof, and molten metal and slag flow from the furnace continuously. The electrodes are of the Soderberg type, formed *in situ* by pouring a mixture of pitch and tar plus anthracite into a steel tubular shell. The process is carried out several metres above the furnace, and as the electrode is lowered, it bakes, so driving off the volatile binding. By the time it enters the furnace it is a solid mass. Electrodes capable of carrying very high currents up to 120 kA, can be produced in this way.

9.6.2.2 Vacuum arc furnace

The vacuum arc furnace (Figure 9.18) is used primarily for remelting metals of very high quality, including titanium, tantalum, niobium, hafnium, molybdenum, tungsten, zirconium, and for refining some steel and nickel alloys. Ingots of up to 100 t can be produced. The furnace operates at low pressure, down to about 0.01 Pa, and very effective degassing of the droplets of molten metal (which have a high surface area) occurs. The ingot forms a molten 'skull' which freezes in contact with the copper mould, thus eliminating contamination from refractory linings and the relatively low volume of liquid present minimises thermal stresses and piping at the ends. Impurities either evaporate or collect in the molten pool on the ingot surface. The electrode is either prefabricated or melted first in a vacuum induction furnace; the arc is d.c. and operates with a current of 10–25 kA and a voltage of 20–30 V. A low voltage is used to prevent the arc attaching to the walls of the vessel, and an additional field coil, which interacts with any radial component of arc current, tends to help the stabilising effect and produces a strong stirring action.

9.6.2.3 Electroslag refining

Electroslag refining (Figure 9.19) is directly competitive with vacuum arc processes for materials not unduly reactive in air. A high degree of refining can be obtained, since the

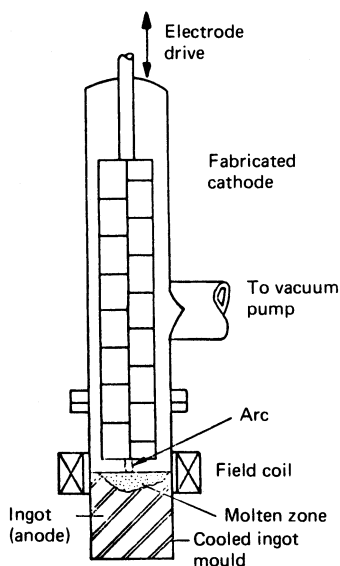

Figure 9.18 Vacuum arc furnace

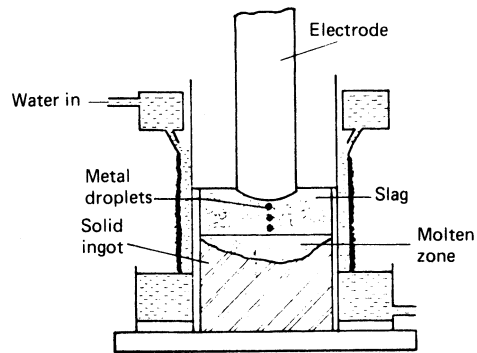

Figure 9.19 Electroslag refining furnace

droplets of molten metal penetrate through the molten slag, enabling desulphurising to be carried out and oxide inclusions to be removed. The process, like the vacuum arc furnace, forms a molten pool on the solidifying ingot and has similar advantages.

The electroslag refining process is essentially one of resistance heating, since it relies on electrical conduction in the molten slag. Single- or three-phase operation (using three electrodes over one ingot) is possible. The operating voltage is kept in the range 40–60 V to prevent formation of arcs, and currents of up to 3 kA are used. Operation is controlled by limiting the voltage and keeping the electrode immersed in the electrically conducting slag in order to avoid drawing an arc. The slag depth and composition are carefully controlled to maintain its electrical conductivity and to allow it to refine the molten metal droplets. Cylindrical and slab ingots can be produced: typical ingot diameters are 350 mm (single-phase) and 900 mm (three-phase), with a melting rate of 180–360 kg/h at 360 kVA (single-phase) or up to 6 MVA at 180 V and 18 kA (three-phase). Large ingots can be produced by switching electrodes during refining.

9.6.2.4 Electron-beam furnace

Electron beams are used for welding, melting and the production of evaporated coatings. The beam is obtained from a heated filament or plate and is accelerated in an electron gun by a high electric field produced by one or more annular anodes. Electrons on the axis of the gun pass through the final anode at very high velocities (e.g. 8.5×10^7 m/s at 20 kV). The electron gun and chamber are kept at a low pressure of around 10^{-3} Pa and, as little energy is lost from scatter or production of secondary electrons, practically all the kinetic energy of the beam is converted to heat at the workpiece. Thus the conversion efficiency of electrical energy input to thermal energy in the workpiece is very high. The electron-beam furnace (Figure 9.20) utilises a cooled ingot mould in the same way as the vacuum and electroslag furnaces.

Ingots, slabs, tubes, castings, pellets and powder can be produced. One system, shown in Figure 9.20, comprises one, two or three guns arranged around a consumable electrode. Individual power ratings up to 400 kW are possible, which enables total power inputs of up to 1.2 MW and melting rates of 500 kg/h to be obtained.

9.6.3 Coreless induction furnace

The coreless furnace essentially consists of a refractory crucible encircled by a solenoid coil excited from a single-phase

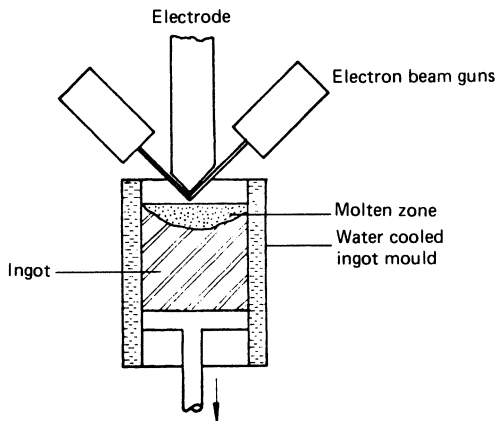

Figure 9.20 Electron-beam melting furnace

a.c. supply (Figure 9.21). The fluctuating axial magnetic field linking the charge within the crucible causes I^2R heating within it. The power induced in the charge depends on the physical properties of the material, the magnitude and frequency of the flux linking it and its geometrical shape. For efficient energy transfer to the load, the cross-section of the current paths must be greater than three times the penetration depth of the electromagnetic wave in the material.

This penetration depth δ is given by equation (9.2). Thus, to melt individual components of charge contained in the crucible, the components must have dimensions lying across the coil axis of 3δ or the voltage generated between the individual components must be sufficiently high to establish current paths of sufficiently large diameters within the bulk of the charge.

Depending on the resistivity of the material being melted, the coreless furnace converts electrical energy to heat in the charge at an efficiency of between 60 and 85%. It is useful to note that, for most furnace designs, the total circuit reactance is far greater than the resistance (by as much as an order of magnitude) and the largest reactive component is

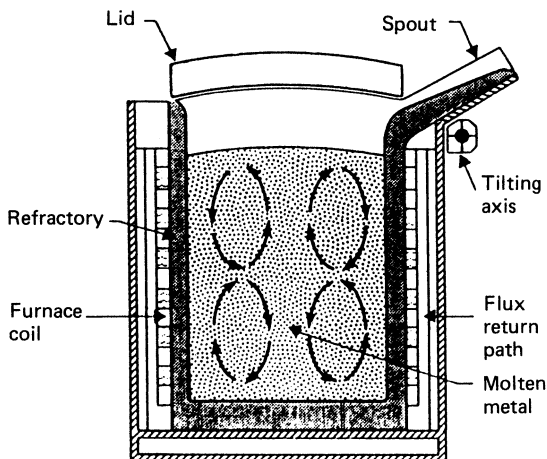

Figure 9.21 Diagrammatic view of a coreless induction furnace

caused by the separation of the coil from the metal charge. The change in the reactance of the charge causes the total circuit reactance to change by about 30% when melting typical iron scrap charges. In addition, lining wear or build-up of slag or dross on the walls of the crucible typically alter the total circuit reactance by a further 30%. It is also seen that, as the frequency of the supply increases, there is a reduction in the circuit power factor. The furnace efficiency, however, is independent of frequency, although it is improved by a high charge permeability such as when melting ferromagnetic materials, e.g. steel scrap.

Water cooling of the induction coil is required to remove the I^2R losses from it—the resulting steep thermal gradient through the crucible wall then improves its integrity in maintaining a separation of the melt from the induction coil. Normally, the coil is manufactured from a thick-walled high-conductivity copper tube, and the design is a compromise between mechanical, electrical and hydraulic requirements. The coil, in the most common modern designs is wound with electrical insulation and the turns are separated using studs, fastened to each turn and arranged in vertical rows, held in place by hardwood pillars. This coil assembly is then restrained vertically and radially by the furnace structure.

For small furnaces, the furnace body can be made from high-strength insulation boards or aluminium side-panels interconnected by non-metallic components, but for larger furnaces (say over 1 t iron capacity) the furnace body is made from a steel frame or from rolled-steel plate. In this case, an electromagnetic screen must be interposed between the coil and its supporting structure. This improves the power factor and coil efficiency compared to the unscreened smaller furnace design, but the lamination packs introduce a small iron loss component.

In recent years, the capital cost of coreless melting furnaces has been significantly reduced in real-money terms, for a given melting rate. This has been due to the development of high-power-density furnaces fed at medium frequency via the solid-state inverter.

Inverter power sources are designed to allow the output frequency to alter to maintain tuning to the natural frequency of the coil system. Thus, capacitor switching is eliminated and the power applied to the furnace is dependent solely on the limits of current and voltage within the inverter, these being chosen to allow substantially constant power input to be achieved throughout the melting of a cold charge, the load conditions of which will change during the total melt cycle.

Inverters used are of the a.c. to d.c. type, and conversion efficiencies of mains to medium-frequency power of over 95% are achieved. Two circuit designs compete in the furnace market, both being capable of giving similar melting efficiencies. These are the current-fed inverter (parallel inverter) and the voltage-fed inverter (series inverter).

The current-fed inverter operates at a leading output power factor and follows the load resonance of the circuit, control of power being by phase-angle control of the inverter rectifier stage. The voltage-source inverter operates slightly below the resonant tank frequency, and power control is achieved by moving the operating frequency away from the resonant condition, allowing a fixed rectification input stage to be used.

The load characteristics imposed on the supply are determined by the rectifier input stage, the harmonics generated being determined by the pulse number of the rectifier. For six-pulse inverters, the predominant harmonics are the fifth and seventh, and for 12-pulse the eleventh and thirteenth, respectively.

Six- or 12-pulse input stages are used, depending on the supply requirements. Individual rectifiers are rated up to

2 MW, and for higher ratings units are connected in parallel. The voltage-source inverter presents a fixed input power factor to the supply but the current-fed inverter, which uses a controlled rectifier input stage, has a load-dependent input power factor. Inverter bridges up to 1 MW from four devices are used and, to achieve higher ratings, devices are connected in series or parallel. Circuit protection is important for long-term inverter reliability, the current-source inverter being easier to protect because of the absence of the high stored energy which must be dissipated in the voltage-source inverter.

The magnetic field reacting with the induced currents in the melt causes forces to be applied to the liquid metal in the furnace, resulting in a surface stirring action which can be advantageous in assisting with dissolution of alloy additions or newly added charge materials. The magnetic pressure creates a metal surface which is dome shaped and the height of this dome (also termed the meniscus), ultimately sets a limit to the power density which can be tolerated. The limiting power density is sometimes empirically taken as linearly related to (frequency)^{1/2}.

For molten iron, the limit to power density is around 300 kW/t for a mains-frequency furnace, although the meniscus lift can be dampened by using a larger ferrostic head above the power coil. By comparison, power densities of up to 750 kW/t are acceptable when using medium frequencies, in the range 180 Hz to 10 kHz. However, metal surface movement markedly increases at the lower frequencies, benefiting assimilation of alloys and light materials. Thus, where this is a significant factor, frequencies of around 250 Hz or even lower are preferred. As lower frequencies are chosen, the voltage generated between individual charge pieces becomes less (for a given furnace power and size), since this is related to the voltage per turn of the furnace coil, which is proportional to $f^{3/4}$. Thus, the lower frequency furnaces are more dependent on the characteristics of the charge pieces than furnaces of higher frequency, and hence choice of frequency has to be a compromise, at least for a given furnace rating and size, and should take into account the required surface stirring action.

Since the first application of large, high-power-density medium-frequency coreless furnaces in the UK (around 1980), the iron-foundry trade has chosen this type of furnace for virtually all new electric melting schemes.

In common with the iron-foundry sector, the lower cost, greater flexibility, and higher power density advantages of modern medium-frequency induction furnaces have tended to eliminate mains-frequency furnaces from consideration for the majority of coreless melting applications in the non-ferrous metals sector.

The low heat requirements to melt lead and zinc generally militate against induction melting, whereas the high melting temperatures of copper alloys are not as efficiently met by other fuel types. Undoubtedly aluminium is the metal which is melted in the widest range of furnaces employing the widest range of fuels and melting practices. There has been significant growth of induction furnaces particularly for recycling in furnaces varying from 0.5 to 8 t capacity.

In the foundry sector several variations of the basic coreless furnace can be found. For example, in furnaces of up to 1 t capacity melting copper and its alloys, parallel-sided clay graphite or silicon carbide crucibles may be used in preference to conventionally refractory-lined furnaces, although consideration must be given to the heat generated directly in these graphite-based materials, particularly the more highly conducting carbon bonded silicon carbide types. This is of special importance in free-standing crucible furnaces generally in the form of push-out or, more recently, by drop coil

designs. These furnaces have been rapidly accepted by the foundry sector because of the ability to melt small batches of metal very quickly, e.g. 60 kg in 13–14 min. At the end of a melt, crucibles can be removed from the vicinity of the power coil and carried directly to the casting mould. Inter-melt contamination is avoided by using different crucibles for each alloy type.

9.6.4 Channel induction furnace

During the 1970s, the channel furnace became accepted as a melting unit for cast iron, and this acceptance was largely due to the improved refractory technology allowing useful levels of power to be applied. Up until then, in iron foundries, the furnace had mainly found application for metal holding.

Electrically, a mains-frequency solenoid coil encircles one leg of a lamination pack and the resultant alternating magnetic field induces Joule heating in a loop of molten metal which surrounds the coil, this metal loop acting as a single-turn secondary of the transformer (*Figure 9.22*). The close coupling between the induction coil and the metal loop provides a higher natural power factor than occurs with the coreless induction coil, and the metal loop provides a higher natural power factor than occurs with the coreless induction furnace. The efficiency of converting electrical energy into heat in the metal is therefore also higher, being above 95%. The molten-metal loop needs to be continuous, and it is not allowed to solidify in case this continuity is broken during contraction. The loop is contained by refractory, enclosed usually within a rigid-steel inductor box, and this can be separated from the main furnace body to allow refurbishment of the inductor box refractory. To mechanically support the refractory between the loop and the induction coil, a bushing, which may be a water-cooled jacket, is interposed (electrically divided into two). The cooling system is designed to produce a steep thermal gradient in the refractory, so improving its integrity.

For melting cast iron, the furnace normally consists of a vertical cylindrical bath having the inductor box attached to its base. The refractory in the main bath is able to be heavily thermally insulated.

The melting power can be applied continuously during the whole of the charging period, and this provides a very consistent and repeatable melting routine.

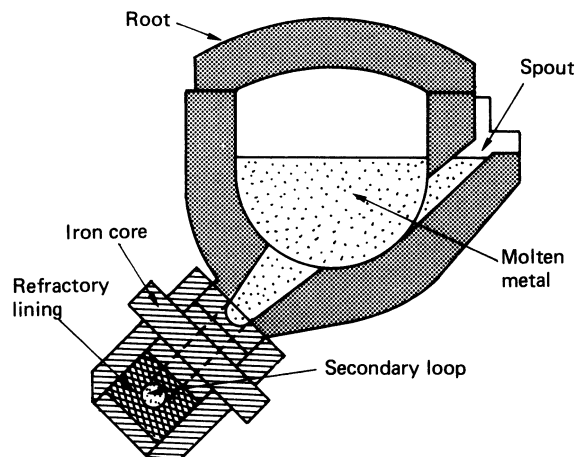

Figure 9.22 Diagrammatic view of a channel induction furnace

The use of channel furnaces for aluminium melting has been constrained by problems of oxide build up in the loop necessitating special designs to allow easy cleaning. In recent years European furnace companies and research workers alike have attempted to produce high-power designs of up to 1.3 MW per inductor with freedom from loop blockage for bulk melting applications, thus utilising the high electrical efficiency of the furnace to minimise melting costs.

9.6.5 Resistance furnaces

Electric radiant-heating techniques for metal melting are most widely employed in the zinc and aluminium foundry sectors with only minor penetration into the higher melting point copper base alloy market. In general, resistance heating is used where metal demand patterns are not appropriate to induction furnaces and hence should not be considered as a competitive technique. For example, furnaces for aluminium range from bale-out-crucible furnaces of 25 kg capacity to well insulated box-like receivers of over 10 t capacity.

Resistor elements may be in the form of wire (e.g. iron–chromium–aluminium alloys) which can be mounted in various configurations, or for higher temperature applications silicon carbide rods either of conventional or spirally cut tube section.

A particular advantage of electric resistance heating is superior metal temperature control, achieved by feedback to the power supply. The simplest power supply comprises direct on-line switching of, for example, a three-phase 415 V mains supply feeding a star-connected element configuration, control being achieved by means of a contactor. Although this is acceptable for wire elements, time-dependent resistance changes of silicon carbide elements (ageing) usually demand voltage regulation which can be effected by a tapped transformer. At power inputs of 50 kW it often becomes more economical to use thyristor circuitry controlling power by means of phase-angle control or burst firing. In the former case, the resulting waveform is not purely sinusoidal and harmonics can be developed at odd integer values of the fundamental (third, fifth, seventh, etc.). A three-phase open delta system (or six-wire load) is usually favoured for silicon carbide element furnaces for two reasons:

- (1) to minimise the presence of triple harmonics in the supply lines; and
- (2) to allow independent control of each phase load in the event of, for example, partial load failure.

In this configuration, harmonics create r.m.s. current levels in excess of those normally expected for a purely resistive load and, therefore, cable sizes need to be increased.

Burst firing does not generate the type of harmonics described above, but can cause flicker on tungsten filament lamps discernible to the human eye. This is due to particular combinations of voltage fluctuation caused by load 'steps' or bursts, and their frequency. Undue voltage fluctuation is minimised by careful selection of supply cable impedance. Thyristor control may also be used in preference to direct on-line switching in situations where close temperature control is required.

Crucible furnace designs comprise a steel shell containing insulating material, heating elements and a carbon based crucible located in the central chamber (*Figure 9.23*). The highest ratings are around 120 kW, giving a maximum melting rate of 230 kg/h (aluminium) in a 600 kg capacity furnace. Crucible furnaces exist in both tilting and bale-out configurations, and great strides have been made to improve performance figures in the light of competition between

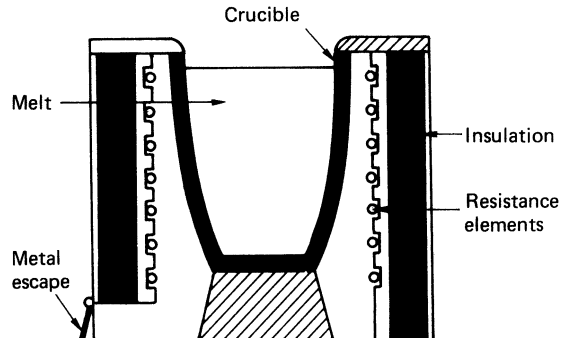

Figure 9.23 Diagrammatic view of a resistance crucible furnace

manufacturers and from other fuels. For example, a typical 180 kg capacity bale-out furnace has a holding requirement of about 4 kW with advantages of automatic start-up, good working environment and close temperature control.

Bath-type furnaces, using roof-mounted elements radiating onto a refractory lined bath of metal, are available for a wide range of metal melting and, more commonly, metal storage applications. The rate of heat transfer to the melt is limited by the low emissivity of the melt surface, a factor which, conversely, is of considerable advantage in reducing heat losses during normal bale-out applications. Since heat transfer is also proportional to bath surface area, significant melt rates are achieved only with high-capacity furnaces. Typically, the metal content is around eight times the optimum hourly melt rate achieved when these large structures have reached thermal equilibrium.

For bulk storage and dispensing applications, good thermal insulation techniques have led to the development of integrated systems in which low-power mineral-insulated elements operate around 2–3 kW/t of metal capacity.

Immersion heating using silicon carbide or wire elements in silicon carbide based tubes provides an alternative high-efficiency heating mode for lower melting point metals.

9.7 Dielectric heating

Processing of non-metals by the conventional heating techniques of convection, conduction and radiation is often limited by the physical characteristics of the materials such as thermal conductivity and temperature sensitivity. Furthermore, since all these modes of heating depend on the transfer of heat through the product surfaces there is inevitably a temperature gradient between the surface and the centre, a problem which increases as the thickness of the product increases. In many operations this is undesirable, leading as it does to process inefficiencies and product degradation. Dielectric heating which covers both the r.f. and microwave parts of the electromagnetic spectrum can, in many circumstances, alleviate these problems by virtue of its 'volumetric' or at least deep penetration form of heat transfer. The industrial applications of dielectric heating are many and varied ranging from drying of textiles and the welding of plastics to the thawing of meat and the heating of rubber extrusions. Dielectric heating depends on a number of polarisation effects, the most commonly described one being dipole orientational polarisation (*Figure 9.24*). This is very important at microwave frequencies, but of relatively little significance at the lower, radiofrequencies.

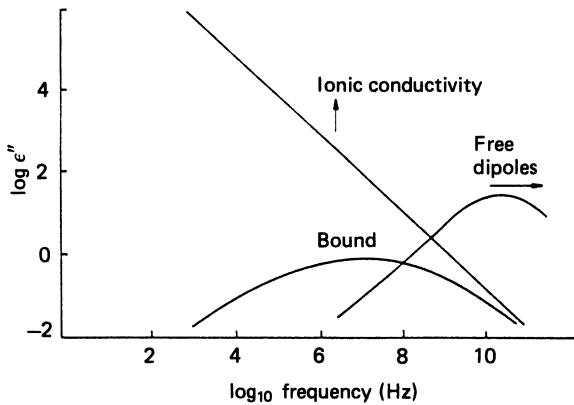

Figure 9.24 Dielectric properties of water: variation with frequency and temperature. Arrows indicate change with increase of temperature

The dominant mode in the r.f. range is space charge orientation, which in turn is dependent on the ionic conductivity of the material being processed. Therefore, for a particular material it is possible in theory to choose the most appropriate frequency from those available in the industrial, scientific and medical (ISM) bands (*Table 9.8*). In reality, many products can be processed by either r.f. or microwave and the choice of which can be made on other considerations such as the engineering required to make a satisfactory enclosure compatible with the process line requirements. The heat transferred per unit volume of product is given by

$$P = 2\pi f \varepsilon_0 \varepsilon_r'' E^2 \quad (\text{W/m}^3) \quad (9.3) \Leftarrow$$

where f is the frequency (MHz), E is the electric field strength (V/m), and ε_r'' is the loss factor or relative permittivity.

Table 9.8 Frequency allocation for industrial, scientific and medical purposes (existing allocations, 1980)

Frequency (MHz)	Frequency tolerance (\pm)	Area permitted
0.007	10 kHz	USSR
13.56	0.05%	World-wide
27.12	0.6%	World-wide
40.68	0.05%	World-wide
42, 49, 56, 61, 66	0.2%	Great Britain
84, 168	0.005%	Great Britain
433.92	0.2%	Austria, Netherlands, Portugal, W. Germany, Yugoslavia, Switzerland
896	10 MHz	Great Britain
915	13 MHz	North and South America
2375	50 MHz	Albania, Bulgaria, Hungary, Romania, Czechoslovakia, USSR
2450	50 MHz	World-wide, except where 2375 MHz is used
3390	0.6%	Netherlands
5800	75 MHz	World-wide
6780	0.6%	Netherlands
24150	125 MHz	World-wide
40680		Great Britain

The loss factor, i.e. the product of the dielectric constant and the loss tangent, varies with a number of parameters including frequency, moisture content and temperature. The relationships are often quite complex as, for example, in drying where as the temperature of the material rises the moisture content will start to fall. However, one of the major applications of dielectric heating, moisture profile correction, takes advantage of the relative values of loss factor between areas of high and low moisture concentration. These are such that preferential heating and drying of the wetter areas takes place with resulting product quality improvements. *Table 9.9* gives an indication of the loss factor of a number of materials for a range of frequencies; some are quoted at a number of different temperatures. Interpretation of such data needs to be undertaken with care. In the case of water the effect of having any level of ionic material present (as in most 'real' water), will substantially increase the loss factor at r.f. but have relatively little effect at microwave frequencies.

In common with all high-voltage equipment, it is necessary to prevent access to live components and in this case it is also necessary to contain the electric field for both operator safety and to avoid interference with other users. Both considerations are dealt with by enclosing the equipment in a metal case, which may have interlocked access doors for batch operations and attenuating ducts for continuous processes.

9.7.1 RF dielectric heating systems

The available systems for producing and transferring RF power to dielectric heating or drying applicators can be divided into two distinct groupings; the more widespread *conventional RF heating equipment*, and the more recent *50 Ω RF heating equipment*. Although conventional RF equipment has been used successfully for many years, the

Table 9.9 Typical loss factor and frequency relation

Material	Temperature ($^{\circ}\text{C}$)	Frequency (MHz)				
		1.0	10	100	3000	
Ice	—	0.50	0.067	—	0.003	
Water	1.5	1.6	0.17	0.61	25	
	15	2.5	—	—	16	
	65	5.6	—	—	4.9	
	95	7.9	0.72	0.17	2.4	
Porcelain	25	0.015	0.013	0.016	0.028	
Glass	Borosilicate	25	0.002	0.003	0.004	0.004
	Soda-silica	25	0.07	—	0.051	0.066
Nylon (610)	25	0.07	0.06	0.06	0.033	
	84	0.76	0.43	0.23	0.10	
PVC	20	0.046	0.033	0.023	0.016	
	QYNA	96	0.24	0.14	0.086	—
VG5904	25	0.60	0.41	0.22	0.10	
	VU1900	25	0.29	0.17	0.087	0.015
Araldite (E134)	25	0.34	0.41	0.48	0.15	
	Adhesive	25	0.11	0.12	0.11	0.07
Rubber (natural)	25	0.004	0.008	0.012	0.006	
Neoprene (GN)	25	0.54	0.94	0.54	0.14	
Wood (fir)	25	0.05	0.06	0.06	0.05	
Paper (royal-grey)	25	0.11	0.16	0.18	0.15	
	82	0.08	0.14	0.19	0.23	
Leather (dry)	25	0.09	0.09	0.12	—	
	15% water	25	0.78	0.49	0.45	—

ever tightening EMC regulations, and the need for improved process control, is leading to the introduction of RF heating systems based on $50\ \Omega$ technology.

9.7.1.1 Conventional RF heating equipment

In a conventional system, the RF applicator (i.e. the system which *applies* the high frequency field to the product) forms part of the secondary circuit of a transformer which has the output circuit of the RF generator as its primary circuit. Consequently, the RF applicator can be considered to be part of the RF generator circuit, and is often used to control the amount of RF power supplied by the generator. In many systems, a component in the applicator circuit (usually the RF applicator plates themselves) is adjusted to keep the power within set limits. Alternatively, the heating system is set up to deliver a certain amount of power into a standard load of known conditions, and then allowed to drift automatically up or down as the condition of the product changes. In virtually all conventional systems, the amount of RF power being delivered is only indicated by the d.c. current flowing through the high power valve (usually a triode) within the generator.

A typical conventional RF heating system is shown schematically in *Figure 9.25*.

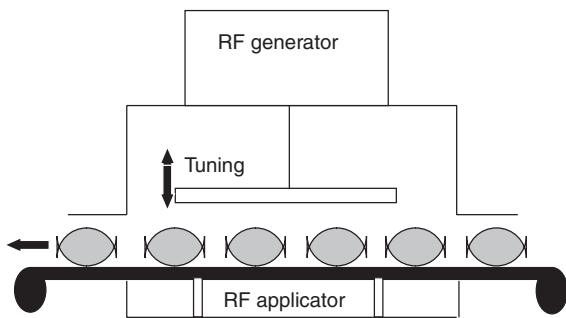

Figure 9.25 Components of a conventional RF heating system

9.7.1.2 $50\ \Omega$ RF heating equipment

RF heating systems based on $50\ \Omega$ equipment are significantly different, and are immediately recognisable by the fact that the RF generator is physically separated from the RF applicator by a high power coaxial cable (*Figure 9.26*).

The operation frequency of a $50\ \Omega$ RF generator is controlled by a crystal oscillator and is essentially fixed at exactly 13.56 MHz or 27.12 MHz (40.68 MHz is seldom used). Once the frequency has been fixed, it is relatively straightforward to set the output impedance of the RF generator to a convenient value— $50\ \Omega$ is chosen so that standard equipment such as high power cable and RF power meters can be used. For this generator to transfer power efficiently, it must be connected to a load which also has an impedance of $50\ \Omega$. Consequently, an impedance matching network has to be included in the system which transforms the impedance of the RF applicator to $50\ \Omega$. In effect, this matching network is a sophisticated tuning system, and the RF applicator plates themselves can be fixed at an optimum position.

The main advantages of this technology over the conventional systems are:

- (i) Fixed operation frequency makes it easier to meet onerous international EMC regulations.
- (ii) The use of $50\ \Omega$ cable allows the RF generator to be sited at a convenient location away from the RF applicator.
- (iii) The RF applicator can be designed for optimum performance, and is not itself part of any tuning system.
- (iv) The use of a matching network gives the possibility of an advanced process control system. The positions of components in the matching network give on-line information on the condition of the dielectric load (such as its average moisture content). This information can be used to control the RF power, speed of conveyor, temperature of air in applicator etc. as appropriate.

9.7.1.3 RF dielectric heating applicators

Whether conventional or $50\ \Omega$ dielectric heating systems are used, the RF applicator has to be designed for the particular product being heated or dried. Although the size and shape of the applicator can vary enormously, they mostly fall into one of three main types.

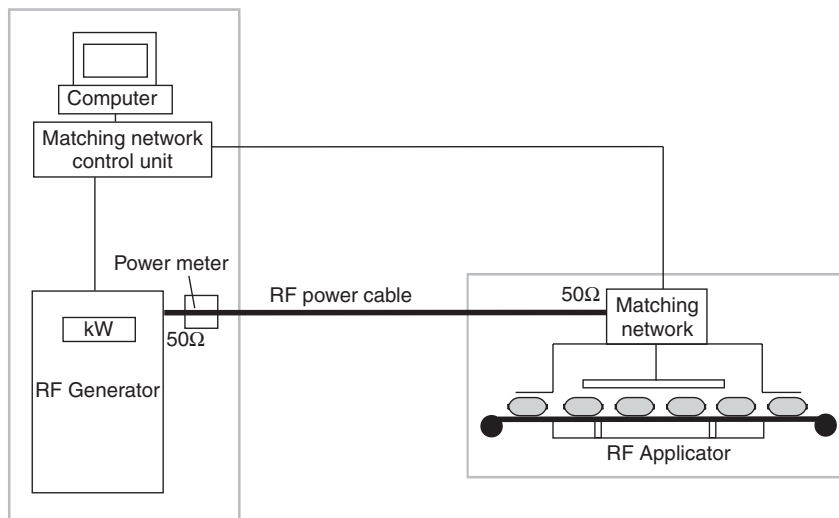

Figure 9.26 The components of a typical $50\ \Omega$ dielectric heating system

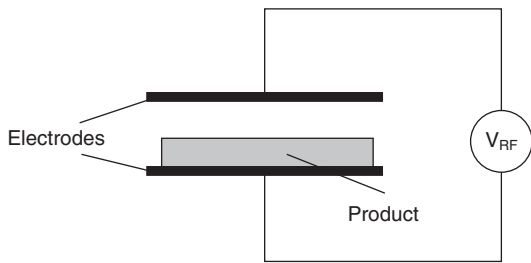

Figure 9.27 Simple through-field RF applicator

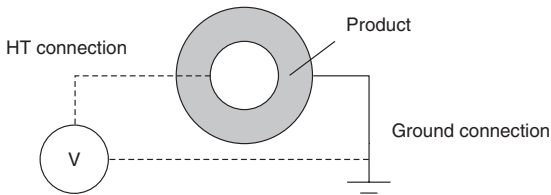

Figure 9.28 Concentric through-field

'Through-field' applicator Conceptually, a through-field RF applicator is the simplest, and the most common, design, with the electric field originating from a high frequency voltage applied across the two electrodes which form a parallel plate capacitor (Figure 9.27).

This type of applicator is mainly used on relatively thick products, or blocks of material.

A variation on this is the concentric through-field, shown in Figure 9.28 in which the product to be heated, normally a liquid or fluidised bed, fills the space between the two cylindrical electrodes. The inner electrode is at high voltage, the outer one at earth potential.

'Fringe-field' applicator An alternative RF applicator arrangement, often used in drying applications, is known as the *fringe-field* system. In this case, the product passes over a series of bars, rods or narrow plates which are alternately connected to either side of the RF voltage supply (Figure 9.29).

The major advantage of this configuration is that the product makes a complete contact across the bars, and there is no air gap between the RF applicator and the product. This ensures that there will be a virtually constant electric field in the material between the bars (an important requirement to maximise moisture levelling performance). It also reduces

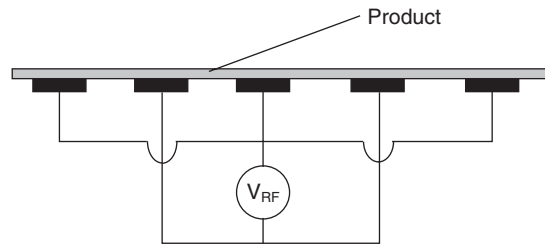

Figure 9.29 Fringe-field applicator

the electric field that has to be applied between the electrodes to generate a given power density within the product. The major disadvantage of this arrangement is that only relatively thin layers of product can be used—otherwise there will be an electric field variation throughout the product thickness.

'Staggered through-field' applicator For intermediate thickness of products, a modified through-field applicator is often used; known as a *staggered through-field* applicator (Figure 9.30).

This arrangement reduces the overall capacitance of the applicator which, in turn, makes the overall system tuning easier. It also reduces slightly, the voltage that has to be applied across the electrodes to produce a given RF power density within the product.

9.7.2 Microwave power sources and applicators

For industrial heating applications using microwaves, the usual power source is the magnetron. At the permitted operating frequency of 2450 MHz, the largest output from a magnetron commonly used, is 5 kW, although 10 kW units are just becoming available. For the other frequency band (896/915 MHz) high-efficiency magnetrons of 60 kW output exist. When higher powers are needed, a number of magnetrons may be fed into one applicator. The most common form of industrial heating oven is the multimode oven, essentially an enlarged version of the familiar domestic oven with, in the case of continuous processing, appropriate product ports, to allow the passage of product yet confine the microwaves within the oven. In such applicators the antenna of the magnetron may be mounted directly into the oven, but more often the microwave power is transmitted from the power supply via metallic pipes (waveguides) to the oven cavity where it is launched into the chamber by a variety of means. Other forms of heating applicator which incorporate, for example, launching horns,

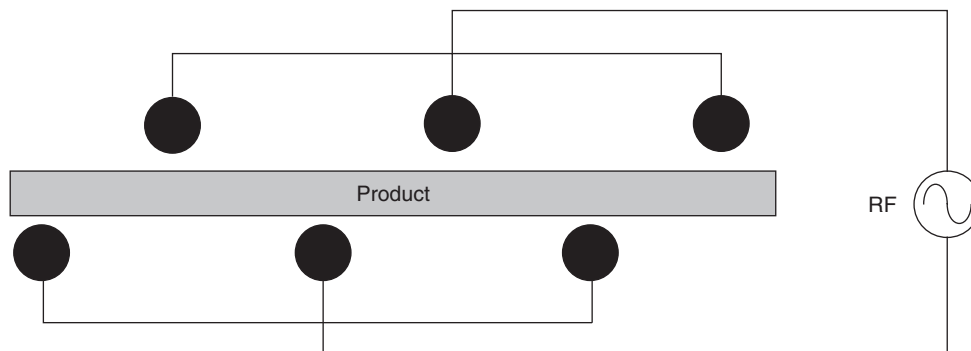

Figure 9.30 Staggered through-field applicator

leaking wave antennas, or single-mode resonant cavities, are possible.

Industrial microwave heating has been used extensively in the rubber industry for curing and preheating prior to moulding. In the food industry it has been used for tempering, melting, cooking and drying. Recently, microwave vacuum dryers have been developed for drying expensive, high-quality temperature-sensitive pharmaceuticals.

9.8 Ultraviolet processes

Inks and surface coatings can be cured at high rates with ultraviolet sources. The coatings are specially formulated, using monomers and photoinitiators, so that very rapid polymerisation is brought about on exposure to ultraviolet radiation. Although this is not strictly a heating process, it has much in common, and is very often in direct competition with infra-red heating for drying or cross-linking; however, the energy usage is normally much lower, since the process requires only the stimulation of an overall exothermic reaction.

The active spectral region covers the range 250–400 nm in the ultraviolet, and visible wavelengths in the range 400–500 nm may also be used. The envelopes of the ultraviolet lamps are usually made from pure silica glass, which has higher transmission than other glass for the shorter ultraviolet wavelengths. Energy radiated from an electrical discharge is not governed by the black-body laws: the

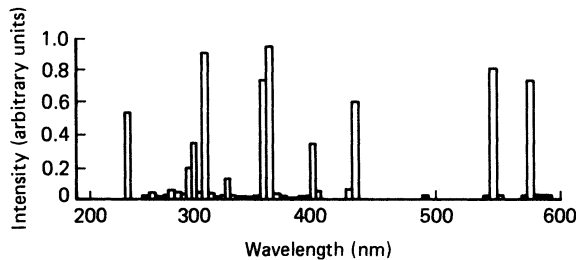

Figure 9.31 Spectral output from a medium-pressure mercury lamp

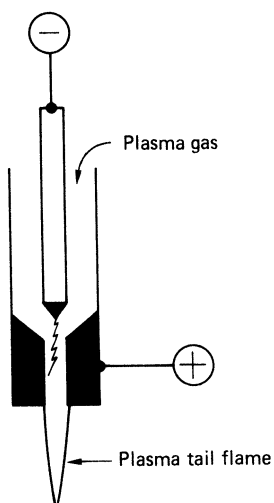

Figure 9.32 Rod and nozzle type of plasma torch construction

distribution can be confined to a few intense narrow bands of wavelength. A typical output spectrum from a medium-pressure (sometimes called high-pressure) mercury vapour discharge lamp is shown in *Figure 9.31*. Additional spectral bands can be generated by incorporating metal halide dopants in the lamp fill. Power ratings of these lamps are in the range 2–20 kW over active lengths of 250–1800 mm.

Low-pressure actinic lamps are used for curing thick sections of glass-reinforced polyester resins. These lamps operate at much lower power densities than medium-pressure lamps, a typical power rating being 80 W for an active length of 1.5 m. Suitable phosphors on the internal surfaces of the lamp tubes convert the primary radiated output, which is concentrated at 254 nm, to broad-band emission in the region 300–500 nm. The lamp tubes are made of glass, which has good transmission properties down to about 300 nm.

Both medium-pressure and low-pressure mercury lamps are used to disinfect air and water, and to sterilise surfaces. Wavelengths shorter than 300 nm are required, the action spectrum peaking at about 260 nm. In the case of low-pressure, 'germicidal' lamps the primary radiated output at 254 nm is utilised. The effect achieved is, again, not the result of a heating process, but the consequence of the biologically damaging properties of ultraviolet radiation.

9.9 Plasma torches

9.9.1 Types of plasma-torch design

A plasma torch is a device that uses an electric arc discharge to generate a thermal plasma, that is, a partially ionised gas in which the degree of ionisation is linked to the temperature of the gas according to the laws of equilibrium thermodynamics. When the temperature of a gas rises above about 6×10^3 C the electrical conductivity becomes sufficiently high to make the gas a reasonable conductor of electricity. Temperatures in the core of an arc may reach 2×10^4 C or higher.

Torches that are used in electroheat applications may be broadly classified into the three families described below.

- (1) *Rod and nozzle electrode types* (*Figure 9.32*): an arc burns between the end of a rod and the internal surface of a nozzle and gas is blown around the arc and through the nozzle. The current supply is usually d.c., but torches designed for a.c. use are also available.
- (2) *Linear coaxial tube types* (*Figure 9.33*): the arc burns between the internal surfaces of tube electrodes and gas is blown through the electrodes around the arc. The current supply is usually d.c., but some designs also operate on a.c. The power-handling capacity is improved if arc root motion is induced by the imposition of axial magnetic fields.
- (3) *Electrodeless types, particularly induction-coupled types* (*Figure 9.34*) and *microwave types*: an induction coupled arc burns in a ring-shaped electric field induced within a coil carrying current typically at a frequency of a few megahertz. The arc plasma is effectively the workpiece in an r.f. induction heater. In microwave torches the arc is maintained by currents driven by microwave fields in a resonant cavity. Peak plasma temperatures in electrodeless torches are typically within the range 7×10^3 to 1.1×10^4 C, that is, rather lower than for the electrode types.

If the plasma torch is intended to handle significant power levels, the electrodes must be adequately cooled to dissipate

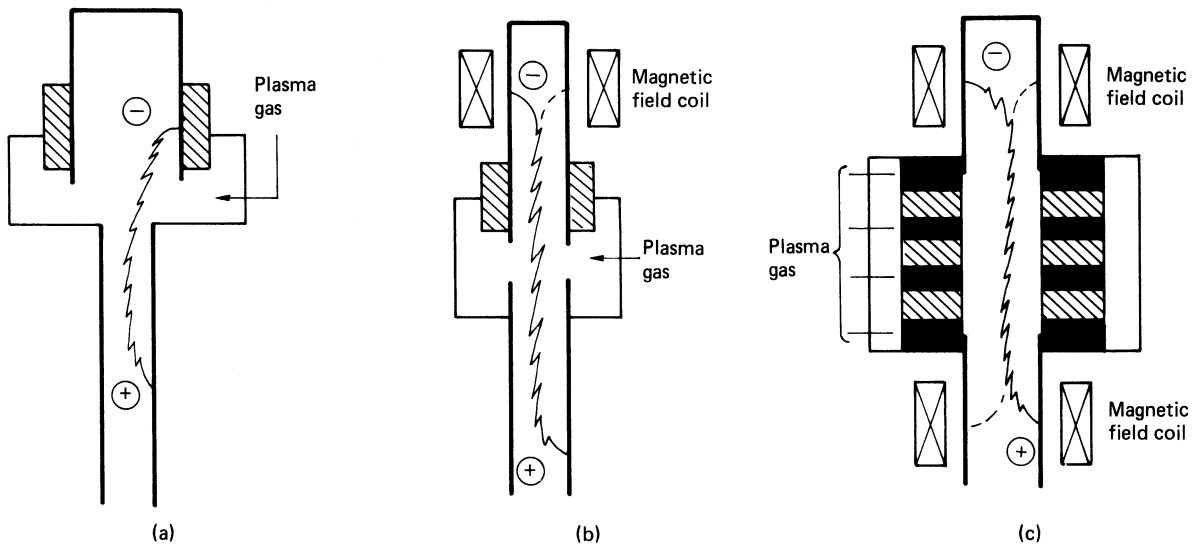

Figure 9.33 Linear coaxial tubular electrode types of plasma torch construction. (a) The Hüls type developed from Schoenherr's original early design; (b) A typical 2 MW non-transferred torch; (c) A typical stretched or segmented torch rated at 6 MW or higher

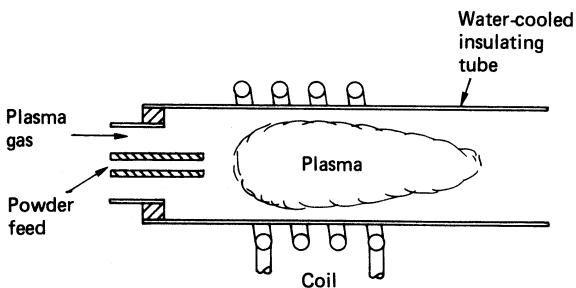

Figure 9.34 An induction-coupled plasma torch

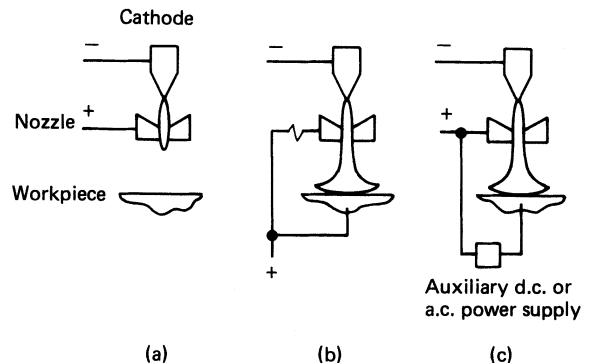

Figure 9.35 Electrical connections of plasma torches. (a) Non-transferred; (b) Transferred; (c) Superimposed mode shown transferred to workpiece

the heat transferred at the arc roots. Water cooling is usual and electrode cooling considerations are critical for torch design. Water cooling may also be necessary for other parts of the torch exposed to the arc plasma.

9.9.2 Electrical connection of plasma torches

Plasma torches are used in various different types of connection (*Figure 9.35*). In the non-transferred mode the torch behaves as an arc-powered gas heater. In the transferred mode the torch behaves as one electrode for an arc while the workpiece is electrically connected as the other electrode.

A third mode of connection, the superimposed mode, is a hybrid connection requiring the use of an auxiliary a.c. or d.c. power source which may be either transferred (as shown) or non-transferred.

9.9.3 Performance

Transferred torches are available for industrial applications at power ratings up to about 7 MW in a single device. State-of-the-art torches are being developed for 12 kA capacity but 6 kA capacity torches are widely available. In most industrial applications voltages up to about 500 V may be accommodated without serious stray arcing but, with care-

ful design, long arcs (1 m or longer) operating at up to about 1 kV are possible. Electrode life-times are dependent on the torch current, the materials of construction and the reactivity of the environment to which they are exposed. Life-times over 100 h are usually necessary for application in major industrial process plant.

The efficiency of transferred torches is very dependent on the specific application. Electrical to thermal conversion efficiencies can reach 95% but, in a practical furnace, the efficiency of conversion to heat transferred to the hearth may fall as low as 50% unless heat losses from the arc plasma column are usefully intercepted. The mechanism of heat transfer is mainly convection.

Non-transferred torches are available in power ratings up to about 100 MW, but for industrial applications a practical maximum rating of about 10 MW is imposed by electrode life-time considerations. Life-times of 1000 h and longer are possible in air or in hydrocarbon gases, provided that the current may be maintained below about 1.5 kA.

The efficiency of non-transferred torches may reach 90% for coaxial tube electrode types when used with high gas

flow rates, corresponding to relatively low gas temperatures of 3×40^3 to 4×40^3 °C. The efficiencies of rod and nozzle types, which are generally used for lower power ratings up to 100 kW, tend to be lower at about 60% at best.

The major advantage of electrodeless torches is that reactive gases are more easily maintained in a state of high purity than in other torch designs, and that long torch-component lifetimes are achieved. Their efficiency is limited, by the conversion efficiency to high-frequency power, the coupling efficiency into the plasma and heat losses to the containing walls, to the range 40–60% at best.

9.9.4 Plasma furnaces or reactors

The simplest type of furnace or reactor is, in principle, the 'in-flight' reactor in which the input materials are injected directly into the plasma stream, or even into the torch, and the required processes occur with the reactants all suspended in the plasma stream. In-flight reactors generally require the input materials to be gaseous or finely divided because the time available for the process is short, typically of the order of milliseconds.

Transferred plasma torches are commonly used in open bath furnaces. A return electrode is then usually built into the hearth refractories, but three-phase a.c. and bipolar d.c. multiple torch systems have been developed to eliminate the need for the hearth connection. The feed rate of materials to open bath furnaces is usually controlled to prevent the build up of unreacted materials on the surface, but plasma torch operation has also been demonstrated in a submerged mode.

Non-transferred torches are often used in shaft-type furnaces where a hot reaction zone is created close to the point of injection of reactive plasma gases in the base of a packed shaft. Furnaces with rotating shells are also available, particularly for the fusion of pure refractory compounds (Figure 9.36) or when a long residence time is required as in the treatment of some waste materials.

The advantages of a plasma furnace are that the heat input is independent of the process chemistry, so that highly oxidising or fully reducing furnace atmospheres are equally permissible, that furnace operation may be made largely independent of the physical characteristics of the input materials, that furnace gas outflow rates are reduced to levels that allow the treatment of fine powders without excessive carry-over, that very high temperatures may be

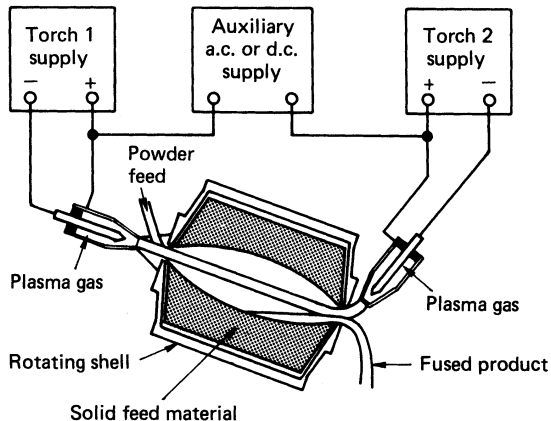

Figure 9.36 Rotating shell furnace for fusing pure refractory powders and using a non-transferred, superimposed mode torch arrangement

Table 9.10 Applications of plasma heating technology

Application	Plasma system
Welding, cutting, surface heat treatment of metals	Transferred, typically up to 100 kW
Precision cutting of metal foils, cutting non-metals	Non-transferred, from 0.5 kW
Spray coating of refractory metals and ceramics	Transferred or non-transferred, typically up to 100 kW, in-flight reactors
Platinum group metals recovery from scrap vehicle exhaust catalyst	Transferred, 1–2 MW
Steel tundish heating	Major application, transferred 1–3 MW
Consolidation melting and cold hearth melting of reactive metals (e.g. Ti)	Transferred, torch anodic, typically 800 kW
Blast furnace blast superheating	Non-transferred, up to 8×2 MW
Plasma fired cupolas	Non-transferred, 4 MW and $6 \times 4=5$ MW
Metals recovery from steel-plant dusts	Major application, from transferred 1 MW to $3 \times 4=5$ MW non-transferred (shaft furnace)
Smelting of metal ore fines	Transferred and non-transferred from 1 MW
Acetylene production, process off-gas reforming	Non-transferred, up to 8.5 MW
Titanium dioxide pigment production	Non-transferred, 2 MW oxygen heater
Waste treatment	Emerging major application

achieved limited only by the containment requirements, and that compact high energy density, high throughput systems, are possible.

Some established applications of plasma technology are listed in Table 9.10.

9.10 Semiconductor plasma processing

Plasma processing has been used in the semiconductor industry since the late 1960s when rudimentary processes were introduced for removing photoresist from silicon using an oxygen plasma. This was an extension of an earlier application in the medical field in which an oxygen plasma was used to volatilise organics from biological specimens in order to separate the inorganic residue or 'ash'. The misnomer 'ashing' is still used in the semiconductor industry to describe this resist-stripping process.

The widespread use of plasmas for semiconductor applications stemmed from work carried out in the early 1970s in which fluorocarbon gases were used to generate highly reactive fluorine atoms and C_xF_y radicals. These species were shown to be capable of etching most of the materials of interest in device fabrication, and the relative etch rates could be controlled by manipulation of the concentration of these species.

More recently, plasma processes have been used for plasma-enhanced chemical-vapour deposition (PECVD) both of insulating films like silicon nitride and also of semi-conducting films such as amorphous silicon (a-Si). The use of PECVD Si_3N_4 for passivation of integrated circuits (ICs) has allowed plastic packaged ICs to have reliability comparable to hermetically packaged devices.

More novel applications of plasma processing include techniques in which material is grown such as *plasma oxidation*—oxidation of existing material or *deposition* of SiO_2 and plasma-assisted epitaxy. As yet these techniques are not in widespread use but offer some significant advantages over their conventional counterparts.

The reasons for the increasing use of plasma processes are three-fold.

- (1) *The requirement for low-temperature processing.* Thermal oxidation and chemical vapour deposition are performed at temperatures in the range 800–1000°C, and sometimes higher. These thermal processes consume a considerable amount of energy leading to an increased thermal budget for the fabrication facility. In addition, they introduce unwanted dopant redistribution, thermal warping, dislocations and stacking faults in the semiconductor substrate. Furthermore, when an aluminium layer is used for circuit interconnection, these elevated temperatures preclude the deposition or growth of further insulating layers; as a result the fabrication of multilayer circuits becomes problematic.
- (2) *The need to etch small geometry structures.* As the dimensions of circuits and devices are reduced, conventional solution or wet-chemical etching becomes more difficult, because the surface tension of the solutions tends to cause the liquid to bridge the space between adjacent features, thereby preventing further etching of the underlying film. As wet etching proceeds downwards through a film, it also proceeds laterally because of its essentially isotropic characteristic, thereby undercutting and broadening lines and restricting the minimum dimensions of the device. In contrast, plasma etching is anisotropic, resulting in a very high ratio of vertical to lateral etch rates. Very steep edge profiles are achievable for interconnection layers with minimal undercutting (see Figure 9.37).

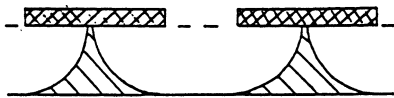

(a) Isotropic (wet chemical)

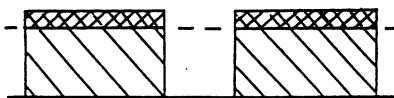

(b) Anisotropic

Figure 9.37 Etch profiles for isotropic and anisotropic etching. Undercutting beyond the mask edge is minimal in the case of anisotropic plasma etching

- (3) *The desirability of a dry process.* Strong acids can be used to strip resist films and to etch semiconductor wafers, but with the associated disadvantages of lack of control and the need for a large amount of high purity chemicals and deionised water. In contrast, plasma etching is a dry process which takes place in a clean vacuum environment. The sources of heavy metal and sodium ion contamination commonly found in solution are eliminated. The process can be monitored by controlling the flow rate of the reactive gases and plasma parameters, and end-point detection of the process is possible.

9.10.1 Basic mechanisms in plasma processing

All plasma processes use a low-pressure gas in the form of a plasma to provide the required chemical species, whether for material removal (etching and ashing) or for material deposition. Free electrons within the plasma processing reactor are accelerated by an applied electric field until they gain sufficient energy to excite some of the parent gas molecules into highly reactive states by collisional processes. The resulting glow discharge, although still mainly composed of neutral ground-state molecules, contains significant numbers of free radicals, ions and other excited species. The degree of ionisation may typically be only of the order of 10^{-4} , but the excited species can be highly reactive, to the extent that reactions either within the body of the plasma, or on exposed surfaces can occur at rates which would only be achieved thermally at temperatures in excess of 1000°C.

These plasma-generation and surface-reaction processes, although widely used, are still not well understood and are very difficult to model. In most systems, however, free radicals are believed to be the major reactant species and ions serve primarily to enhance their reaction rates.

The plasma, due to its degree of ionisation may be regarded as an equipotential volume. Surfaces in contact with the plasma, however, can attain potentials which differ from the plasma potential by amounts which depend upon the configuration of the system and its operating conditions (gas composition, pressure, applied power, excitation frequency, etc.). Because of the higher energies and mobilities of electrons compared to positive ions, electrically isolated surfaces develop a floating potential a few volts below that of the plasma in order to maintain a net charge neutrality. The electric field which maintains this flux neutrality causes a reduction in the electron concentration near the surface, resulting in a plasma sheath, or dark space, where the generation of excited species which decay by photo-emission is much lower than in the bulk of the plasma.

Electrodes in contact with the plasma develop similar plasma sheaths, whose magnitude depends upon the relative areas of the electrodes and the frequency of the RF. Higher frequency = smaller dark space. In most plasma-processing systems the energy is fed into the plasma by capacitive coupling (see Figure 9.38). In a capacitively driven plasma with internal electrodes, a large sheath voltage appears at the smaller electrode and a smaller one at the larger electrode. These voltages are typically of the order of tens or hundreds of volts in practical systems.

The electrode sheaths are usually a few millimetres thick, so that a device wafer with topographical flatness of the order of a micrometre, placed on an electrode does not significantly perturb the field directionality. It is this directionality which gives rise to anisotropic etching in ion-enhanced processes, by enhancing the etch rate in the direction normal to the electrode surface.

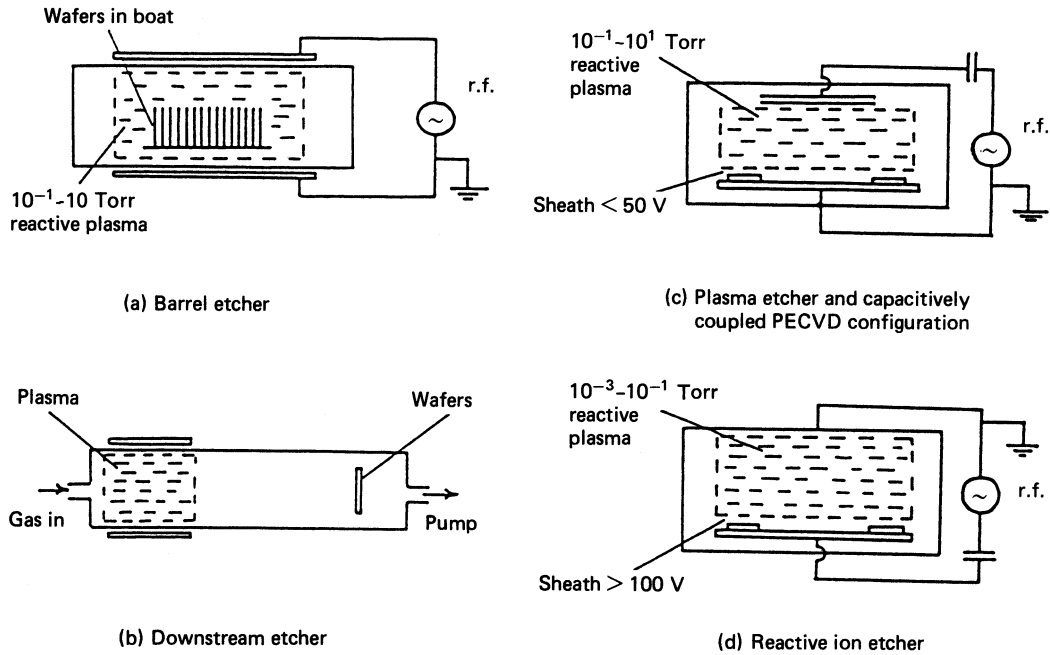

Figure 9.38 Typical configurations for plasma-processing equipment

Table 9.11 Characteristics of the most common plasma etching configurations

Configuration	Etch profile	Selectivity	Etch rate	Type	Range (T)	Electrode arrangement	Wafer position
Barrel	Isotropic	V. good	Fair	Chemical	$10^{-1}-10^1$	External	Immersed in plasma
Downstream	Isotropic	V. good	Fair	Chemical	$10^{-1}-10^0$	External	Downstream of plasma
Plasma etch	Variable	Fair-good	High	Physico-chemical	$10^{-1}-10^1$	Planar diode	Anode (grounded)
RIE	Anisotropic	Fair	Fair	Physico-chemical	$10^{-3}-10^{-1}$	Planar diode	Cathode (driven)
MRIE	Anisotropic	Fair	High	Physico-chemical	$10^{-3}-10^{-2}$	Planar diode	Cathode (driven)
Triode	Variable	Fair	High	Physico-chemical	$10^{-3}-10^{-1}$	Planar triode	Cathode (driven)
RIBE	Anisotropic	Fair	Fair	Physico-chemical	$<10^{-3}$	Planar triode	Cathode (grounded)

9.10.1.1 Plasma etching

A dry etching process (other than physical sputtering) can be described in terms of four sequential steps: generation of the reactive species, adsorption onto the wafer surface, chemical reaction (may be radiation enhanced), and desorption of the reaction products. Any one of these steps may be the rate-limiting step. It is also necessary that the reaction products be volatile in order that the etch products do not contaminate the surface and prematurely terminate the process. For this reason, fluorine or chlorine containing plasmas are used for virtually all inorganic films used in semiconductor applications and oxygen for organics.

Types of plasma etching processes The most common plasma etching configurations are shown in Figure 9.38 and their characteristics are listed in Table 9.11. In chemical plasma etching active species are generated in a reactor by an externally excited r.f. or microwave discharge and the wafers are either immersed in the plasma at a floating potential (barrel etching) or located downstream of the plasma in a gas flow (downstream etching). Ion bombardment is minimal in the former and absent in the latter. Etching is due to free atoms

and excited neutrals and is, therefore, isotropic. With an appropriate choice of etch gas the selectivity can be very high because of the absence of physical enhancement but etch rates are relatively low for the same reason. The lack of anisotropy makes this approach unsuitable for very large scale integration (VLSI) patterning applications, but it is widely used for photoresist stripping (ashing).

By far the most widely used means of achieving directional etching is to use systems in which the wafer is physically bombarded by the ions in the plasma as well as exposed to the chemically reactive gaseous and ionic species. In the plasma etch mode the wafers are placed on the larger (grounded) of two electrodes whereas in reactive ion etching (RIE) they are placed on the smaller (driven) electrode and the system is operated at lower pressure. Under these conditions the ion energies bombarding the wafer are of the order of a few tens of electron-volts in the former and several hundred in the latter. RIE therefore tends to be more anisotropic, but this is gained usually at the expense of reduced selectivity (due to the increased ion bombardment) and reduced etch rate (due to the reduced flux density of reactive species at the lower pressure). However, all of these parameters can be optimised for a given application.

Magnetron-enhanced RIE (MRIE) and triode etching are more recent refinements of this class of operation. In the former case free electrons are magnetically confined in the plasma by a magnetic field orthogonal to the electric field. The collision probability is, therefore, increased and the reactant densities can be enhanced by up to two orders of magnitude. This results in higher etch rates than RIE at similar pressures. The reduced plasma impedance results in lower sheath voltages, but the higher flux of low energy ions is more efficient in promoting physically stimulated processes and so anisotropy is still good, with the added advantage of less radiation-induced damage to the device substrate.

In triode systems, r.f. power is applied to a third electrode in such a way that the cathode sheath voltage is controlled independently of the generation of the reactive species. This allows some degree of decoupling over the physical and chemical components of the process, and thus permits anisotropy and selectivity to be controlled.

Reactive ion beam etching (RIBE) describes the process in which a spatially collimated, usually reasonably mono-energetic, flux of one or more ion species is directed at a substrate leading to etching or erosion of that substrate. Ion energies may be controlled independently of the neutral flux by means of extraction grids.

Choice of etchant For silicon based materials, fluorinated gases have been extensively used, which include CF_4 , C_2F_6 , CHF_3 , SF_6 and, more recently, NF_3 . The major criterion in selection is to create volatile products with the constituents of the target at reasonable working temperatures. Etching other semiconducting materials such as III–V compounds, has required a slightly different approach as the group III fluorides are involatile at workable plasma parameters. For this reason chlorinated gases have been widely used, such as Cl_2 , CCl_2 , F_2 , SiCl_2 and BCl_3 .

9.10.1.2 Plasma enhanced chemical vapour deposition

Chemical vapour deposition (CVD) is a reaction in which two types of gas react at about 1 atm and at high temperature to form a solid phase and a gas phase. Plasma enhanced CVD (PECVD) may be defined as a gas-phase reaction in a low-temperature plasma that forms a similar thin solid film by precipitation onto a substrate. The catalytic effect of the plasma is to accelerate the reaction between the dissociated molecules of the reactant gases. Techniques such as mass spectroscopy and emission spectroscopy allow study of the various reactions within the PECVD process.

The composition and properties of the films vary significantly with substrate temperature and also with the method of generating the plasma. In general, PECVD films are less dense, usually due to the incorporation of hydrogen within the structure. In the case of semiconductors produced by this process, e.g. a-Si, the presence of hydrogen significantly affects both the physical and electronic properties.

Both inductively coupled and capacitively coupled high-frequency power supplies have been used for PECVD, at frequencies ranging from 50 kHz to 13.56 MHz. Of great importance is the power density distribution within the plasma since the life-times of the reactive species are short and must be continually produced in the deposition zone. For this reason the most successful PECVD systems are capacitively coupled and planar in construction—many having developed from the designs of plasma etchers. The introduction of a dilutant gas into the plasma, such as helium, has proved beneficial to film properties. This is

thought to be due to the fact that the helium effectively cools the plasma by reducing the electron temperature and hence reduces damage. Uniformity of deposition in such systems is now better than 3% over 8 in. wafers and the step coverage is very good.

9.10.2 Power supplies for plasma production

Four basic types of power supply are used to excite the plasma in most semiconductor plasma-processing equipment. These are: d.c. supplies, high frequency (h.f.) supplies for the range 20 kHz–1 MHz, radiofrequency (r.f.) supplies for the range 1–100 MHz and microwave supplies. The h.f. and r.f. supplies are the most commonly used.

9.10.2.1 H.f. and r.f. power supplies

R.f. power supplies provide an output current and voltage which are alternating with equal but opposite amplitude at a given frequency. The connection to a plasma system is complicated by the fact that the 'plasma load' or r.f. connection to the system cannot be considered as a simple resistive load, but a load with a complex impedance dependent mainly on pressure, applied field and type of gas. The value of plasma impedance can give rise to substantial phase shifts of applied voltage and current resulting in an energy loss in the plasma reactor due to unwanted dissipation.

The output of a generator has a specified termination impedance or output impedance (most commonly 50 Ω resistive). To achieve maximum power transfer to the plasma the load (plasma) impedance must be equal to the output impedance and this is usually achieved using a π - or L-type impedance matching network. These networks effectively transform the plasma load impedance to that of the output impedance and can be automatically tuned to suit the particular plasma.

For the h.f. case (<1 MHz) the connection of the load to the generator is generally simpler than for r.f. systems since the plasma impedance is more stable, stray capacitances are small and circuit losses insignificant. Such power supplies tend to be used in the inductively coupled mode for PECVD systems. For the r.f. case the most common frequency is 13.56 MHz which is an international allocation for industrial use. For these systems particular care must be taken with the design of components and circuitry. At these frequencies and above, r.f. currents travel in a conductor through its surface and, generally, the penetration (skin depth) decreases as the frequency increases. This means that coils and capacitors, etc., should have highly conducting and large surface areas to reduce losses.

The most widely used r.f. plasma processing system is the parallel-plate configuration with electrodes varying in size from 100 mm to about 1 m, depending on the type and use of the system. It is normal for the base of the chamber to form the substrate holder which is often part of the chamber or a separate earthed electrode. The top (r.f. powered electrode) is usually of a similar diameter, depending on the application, and parallel to the lower electrode. The generator will normally give some visual indication of forward and reflected power and thus allow some degree of control of the generation process.

9.10.2.2 D.c. and microwave power supplies

The d.c. low voltage power supply operates at voltages of 100–800 V and uses a magnetron for plasma confinement. The target or cathode is thus encased in a high density

magnetic field, usually supplied by permanent magnets. This type of supply requires rugged construction as rapid and repeated short circuits can occur from the powered electrode in the plasma system to the positively connected earths at the start of the process. The output current of the supply (typically around 10 A) must also be regulated using closed-loop control, as small changes in the output voltage can create large changes in operating current. A common application of this type of supply is in sputtering equipment.

Plasma excitation by microwaves is also used for semiconductor plasma processing. The frequency of operation is usually 2.45 GHz and most power supplies use a magnetron oscillator with the energy introduced through an isolator into the wave cavity. The microwave circuit is monitored by measuring the power of the incident and reflected waves using a directional coupler. This form of discharge is known as an electrodeless discharge and contamination of the substrate is low. Such supplies are used in etchers, oxidation systems and, more recently, in plasma stream transport systems in which the substrate is placed downstream of the discharge and the plasma transported to it by magnetic flux tubes.

9.10.3 Current trends and future developments

It is certain that semiconductor plasma processing will continue to find increasing application throughout the microelectronics industry. In the field of etching most of the current activity in high fidelity pattern transfer is in the area of physico-chemical processes, and particularly in RIE and its refinements. Submicrometre features can already be defined with vertical or beveled profiles in most of the materials of interest for VLSI applications, but there are still shortcomings in several respects. The enhanced etch rates and lower plasma sheath voltages obtainable with MRIE and triode systems are likely to provide a spur for further developments in these areas. RIBE, because of its flexibility and control over bombardment energy, looks attractive for many applications.

Much research and development is continuing in the field of PECVD of amorphous silicon. Applications of a-Si ICs include solar cells and thin-film transistors for active-matrix liquid-crystal displays. Small flat-screen colour displays to rival the conventional cathode-ray tube are currently available and their use is expected to become widespread in the future.

9.11 Lasers

9.11.1 Introduction

Laser¹ is a compound word which means 'light amplification by stimulated emission of radiation'.² Lasers (or laser devices) basically consist of: (a) a light amplification (or laser) medium; (b) an optical cavity which contains the laser medium; and (c) a pumping source which gives energy to excite atoms or molecules in the laser medium to higher energy levels.

The basic principles involved in producing laser light are shown schematically in *Figure 9.39*. The pumped laser medium has a state of inversion population where a specific upper level has a larger population than the lower level compared to the expected Boltzmann distribution of thermodynamic equilibrium.

Light that passes through such a laser medium is amplified by induced transitions from upper to lower energy

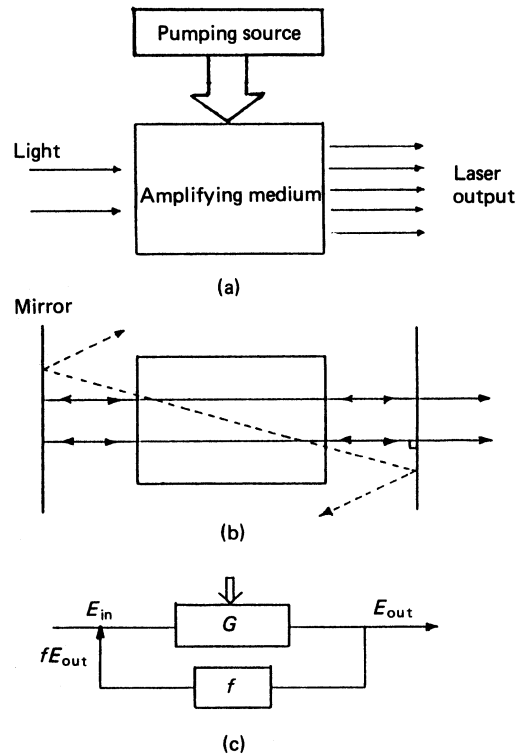

Figure 9.39 Principles of lasers. (a) Light amplification; (b) Optical cavity; (c) Oscillation by positive feedback

levels. Light that is confined in an optical cavity increases its intensity by multiple reflection between two mirrors and multipassage through the laser medium.

The laser medium may be solid, liquid, or gaseous in the form of a plasma (Section 9.10). Depending on the energy levels of the laser transition, the wavelength of laser light may be in the range from X-rays to millimetre waves.

The properties of laser light, compared with ordinary thermal radiation, can be summarised as follows.

- (1) Laser light is an electromagnetic wave which has a high spatial and temporal coherence.
- (2) Laser light has a high spectral purity which is determined by the resonant curve of the optical cavity and the energy level of the laser transition.
- (3) A beam of laser light has a low divergence, the lower limit of which is determined by diffraction as the divergence angle of λ/D , where λ is wavelength and D is the beam diameter.
- (4) The high focusability of laser light gives a small focal spot of the order of a wavelength. This gives a high energy or power concentration in space.
- (5) A very short light pulse can be generated by a laser. The pulse width can be compressed to the order of femtoseconds.
- (6) Well-defined polarised light can be generated by introducing a polariser into the cavity.

These characteristic features of lasers have wide application in modern science and industry.³ Various kinds of lasers are listed in *Figure 9.40* along with their specific wavelengths and performance properties.

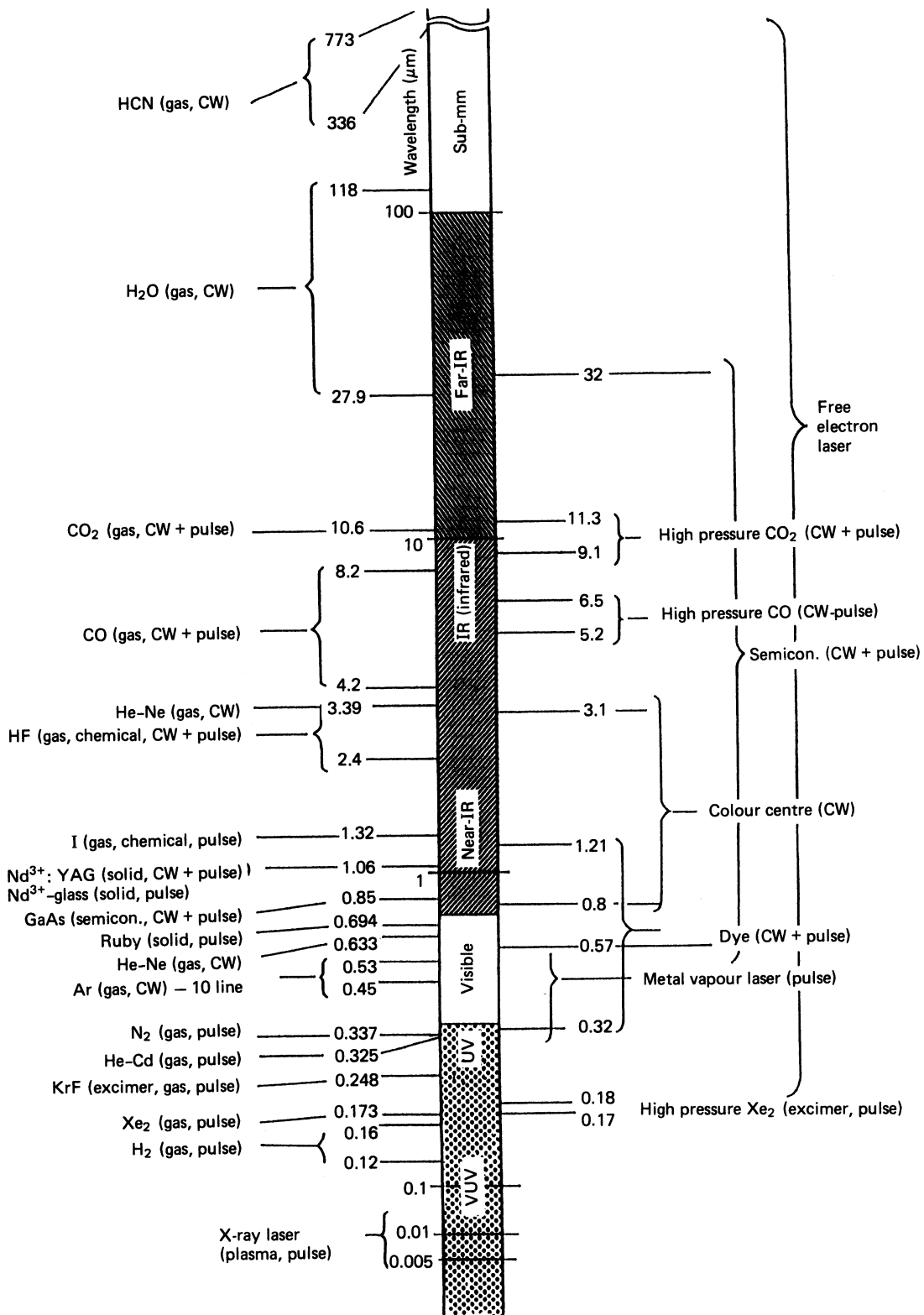
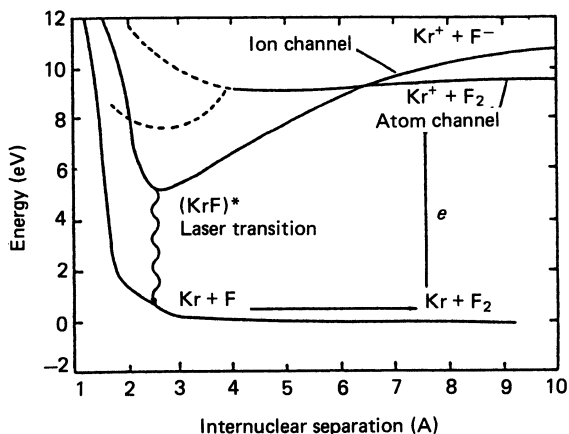

Figure 9.40 Typical lasers and wavelengths. CW, continuous wave; IR, infra-red

Table 9.12 Features and applications of excimer lasers

Excimer	Wavelength (nm)	Output	Efficiency (%)	Application
ArF	193	5–25 ns pulse 1–1000 Hz, ~500 mJ	≤1	Spectroscopy, photochemistry
KrF	248	2–50 ns pulse 1–500 Hz, ~1 J	≤2	Medical, lithography, dye laser pumping
XeCl	308	1–80 ns pulse 1–500 Hz, ~1.5 J	≤2.5	
XeF	351	1–30 ns pulse 1–500 Hz, ~500 mJ	≤2	

**Figure 9.41** Energy-level diagram for the KrF excimer laser

9.11.2 Gas lasers

9.11.2.1 Excimer lasers

Typical excimer lasers that are commercially available are shown in *Table 9.12* along with their wavelengths and performance characteristics. An excimer is an excited molecule $(AB)^*$ which is stable only in its excited state. When the electronic state of A or B is excited or ionised in a mixture of both, they combine to form the excimer $(AB)^*$. A population inversion between $(AB)^*$ and (AB) can be formed because the ground state (AB) is not stable and dissociates to A and B as shown in *Figure 9.41* with the potential curve of $(AB)^*$ and (AB) , as in the example of KrF.

Due to the short life-time of the upper state, excimer lasers operate in a pulsed mode with short-pulse duration. The wide bandwidth gain also enables pulse widths of pico- and femto-seconds to be generated, which is a useful feature for the investigation of high time-resolution phenomena. Repetitive operation of up to 1000 Hz provides a high average power of the order of 100 W.

The high photon energy of the short-wavelength light from an excimer laser, along with its high power capability, provides new application possibilities for photochemical material processing, medicine and as a light source for lithography of large scale integrated circuits.

The KrF laser has the potential for use in nuclear fusion,⁴ which requires an output energy of megajoules per pulse and megawatts average power with high efficiency of 5–10%. A 10 kJ KrF laser has been constructed in the USA and a 100 kJ KrF laser is being planned and designed in

Europe for application to fundamental science and industrial technology.

9.11.2.2 CO₂ lasers

A discharge of CO₂, N₂ and He excites a specific vibrational level of the CO₂ molecule and produces population inversion for laser action. The wavelength of the CO₂ laser extends from 9 to 11 μm, corresponding to the different vibrational-rotational levels. The efficiency of the CO₂ laser is typically 5–15%. The CO₂ laser is the laser with the capability of delivering the highest output power in continuous wave (CW) operation at the present state of technology and a 100 kW laser is commercially available with a high gas flow circulating system in conjunction with a stabilised discharge.

The CO₂ laser is one of the most widely used industrial lasers. The fields of application are material processing, such as cutting, welding, hardening and surface treatment, medical processing, diagnostics and heating of plasmas, and as a pumping source for various infra-red lasers.

9.11.2.3 Other gas lasers

The He–Ne laser is one of the most popular lasers and has been used extensively for diagnostics, data processing and alignment. The ion laser operates at short wavelengths (350–800 nm), and relatively high power (CW 20 W). This laser is used for spectroscopy, dye laser pumping for tunable-laser applications, and laser colour displays. The N₂ laser can generate short pulses of 0.3–10 ns duration at 337.1 nm wavelength (ultraviolet radiation) and with high peak powers of a few tens of megawatts. This laser is used for non-linear spectroscopy and dye laser pumping.

Metal-vapour lasers, especially copper vapour lasers, are under development as pumping sources for dye lasers used for laser isotope separation. Output powers of 100 W to 1 kW at 510 and 578 nm (green light) have been achieved. The He–Cd laser is a three-colour laser emitting at 441.6, 537.8 and 636.0 nm, with a relatively high CW power of 100 mW.

9.11.3 Solid-state lasers

9.11.3.1 Neodymium (Nd): YAG lasers

A single crystal of Nd doped yttrium–aluminium–garnet (YAG) produces laser radiation at a wavelength of 1.064 μm. A xenon flashlamp is used for pumping. The efficiency is relatively high at a few per cent. High average

power of CW or repetitive pulse operation of 100 W to 12 kW has been obtained.

Frequency conversion of the fundamental output at $1.064\mu\text{m}$ has been obtained to give third (355 nm blue light) and fourth (266 nm UV light) harmonics using non-linear optical crystals with high efficiency. This feature of multicolour output leads to applications ranging from thermal to photochemical processing. The technology of crystal growth for manufacturing large laser elements is progressing rapidly and a single crystal of about 10 cm diameter without a central core is already being successfully manufactured. Laser diode (LD) pumping techniques are also under development and an LD pumped YAG laser with high efficiency of 30–40% has been demonstrated.

9.11.3.2 Neodymium:glass lasers

Neodymium doped glass emits radiation at 1.053 or $1.062\mu\text{m}$ when *phosphate* glass or *silicate* glass is used, respectively, as a host material. The thermal conductivity of glass is low, and the cooling rate to remove the residual heat should not be too high. Therefore, the repetitive operation of a glass laser is limited. On the other hand, large laser elements with high optical uniformity can easily be manufactured.

Glass lasers are therefore used for laser fusion experiments where high peak power (terawatt) with short pulse (nanoseconds) is required even without repetitive operation and high efficiency. The largest glass laser amplifier is 45 cm in diameter with segmented elements or 35 cm in diameter with a monolithic element. The largest laser system is the NOVA glass laser at Lawrence Livermore National Laboratory, USA, which can deliver 120 kJ/ns at $1.053\mu\text{m}$ fundamental wavelength and 70 kJ in third harmonics of blue light. The GEKKO XII glass laser at the Institute

of Laser Engineering, Osaka University, which is used for international collaborative research, has output powers of 20 kJ/ns at $1.053\mu\text{m}$, 15 kJ as green and 12 kJ as blue light.

Glass lasers of higher power are planned and are being designed to generate 100 kJ to megajoules output energy as blue light for thermonuclear fusion ignition experiments and also for basic high-energy-physics research.

9.11.3.3 Laser diode and laser-diode-pumped solid-state lasers⁵

Semiconductor diode lasers have progressed in terms of performance and application achievements. One of the most important fields of application is in optical communication with fibre transmission. A wide tunable range with narrow spectral width is required for applications in coherent optical communications with frequency division multiplexing. Laser disks and laser scanners also provide a demand for LDs. High power and long life are the basic requirements for commercial use.

Typical LD performance specifications that have been individually achieved include:

- (1) long life (>10 years),
- (2) high power (>1 W (CW, one junction), >115 W (CW, 1 cm array), >200 W (pulse, 1 cm array)),
- (3) efficiency (>50%),
- (4) spectral purity (<1 MHz (20 mW)), and
- (5) tunability ($\Delta\lambda \approx 2\text{--}6\text{ nm}$).

One of the most important energy applications of LDs is as a pumping source for solid-state lasers. *Figure 9.42* shows the energy levels and absorption spectrum of an Nd laser compared with the emission spectra of a laser diode and an Xe flash lamp. The output emission of the LD can be tuned to the most efficient absorption line for population inversion. Thus the LD laser pump has the potential for high

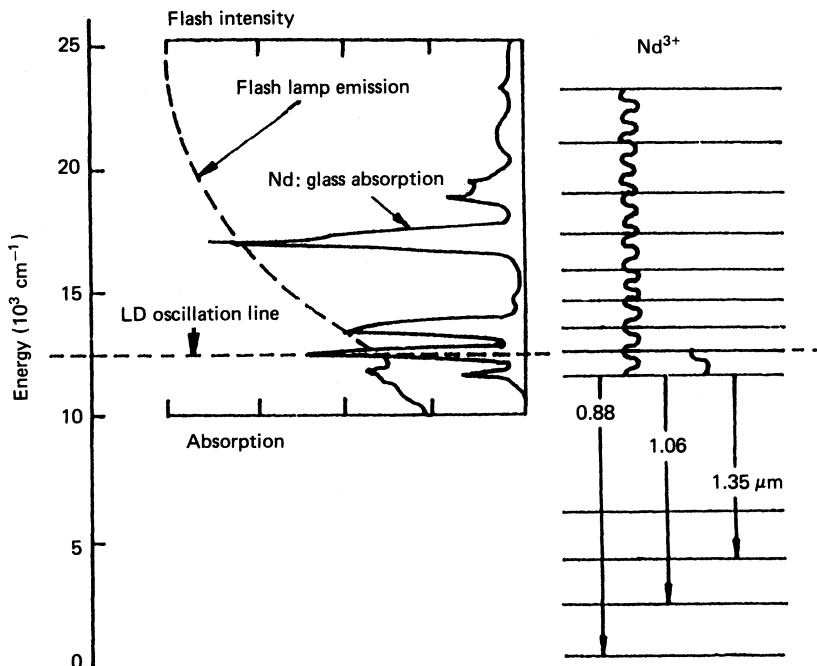

Figure 9.42 Spectrum of Neodymium: glass absorption, flash lamp emission and LD oscillation line. The transition and energy state of the neodymium laser is shown

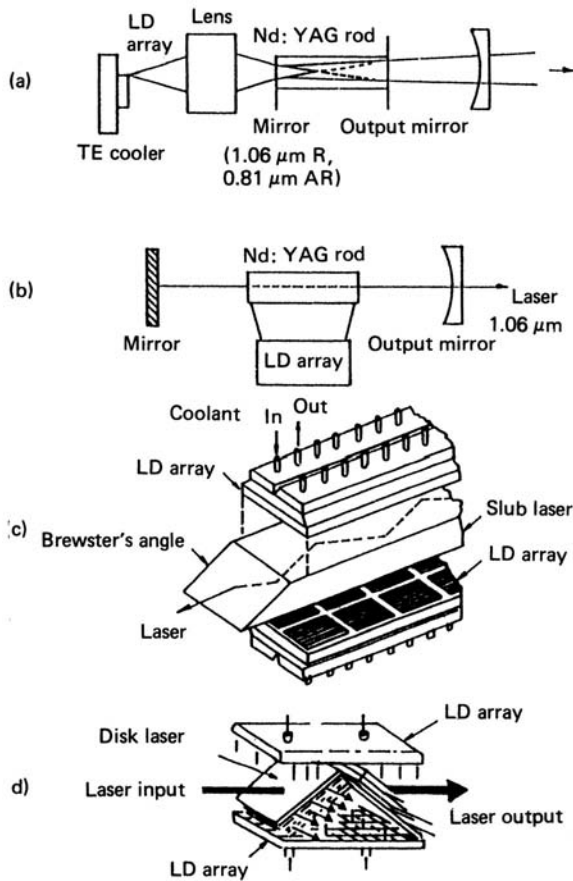

Figure 9.43 LD-pumped solid-state lasers and various layouts. (a) End pump; (b–d) Side pump

efficiency, low residual heat and solarisation for high repetition operation and long life. Solid-state lasers can be assembled as compact and easily manipulated devices by using LD pumping. *Figure 9.43* shows a schematic of an LD pumped solid-state laser. An end-on pumping scheme is suitable for micro-tip lasers with single-mode operation. A side-on pumping scheme is more flexible for assembly with high power lasers. The record for output power is 3.8 W CW with 10.9 W CW pumping or 4.9 W CW with 14 W CW pumping, with end-on pumping and 5 kW with side-on pumping.

Research trends for high-efficiency frequency-conversion technology (to green (2ω), blue (3ω) and UV (4ω) light) and for the development of new solid-state laser materials which have tunability or long fluorescence life-times are opening new fields of laser technology. Together with LD pumping techniques and in conjunction with gas, liquid or solid-state lasers, such trends are leading to new applications of laser technology in science, industry and medicine.

9.11.3.4 Tunable solid-state laser and new materials

The development of new solid-state laser materials is now proceeding rapidly, with the aim of achieving tunability and higher performance characteristics. Many materials capable

of emitting at wavelengths between 680 and 2500 nm are under investigation. These are neodymium or chromium doped garnet–scandium–garnet (GSGG), neodymium, erbium or holmium doped yttrium–lithium–fluoride (YLF), neodymium doped YVO_4 , etc. One of the well developed solid-state tunable lasers is the Ti : Sapphire laser which has a wide tunable range of 660–1180 nm with a high power output.

9.11.4 Application of high-power lasers

9.11.4.1 Laser processing and machining

Laser interaction with matter The interaction of laser beams with matter may be divided into three categories with regard to both physical processes and applications: thermal processes, photochemical processes, and plasma processes.

When a material is irradiated by laser light it absorbs the photon energy at the surface. The efficiency depends on the reflectivity of the surface and hence on such material properties as electrical conductivity or the existence of an appropriate absorption band. The heat on the surface then transfers to the substrate. This process can be calculated from thermal models when the thermal conductivity and heat capacity are known. At higher intensities, melting and evaporation occur. Laser-induced thermal effects provide a wide variety of laser machining technologies.

Another characteristic laser-induced process is the laser photochemical effect or laser-induced chemical reaction. The photochemical effect may be divided into three fundamental physical processes, excitation of molecular vibrational/rotational and electronic states, dissociation of molecules, and photoionisation. These processes may induce subsequent chemical reactions if appropriate reaction materials are introduced. Because laser light has a high degree of monochromaticity, a specific energy state can be selectively excited. This effect provides the means of controlling the chemical reaction by using a tunable laser. The correspondence of photon energy and wavelength produced by a number of typical excimer lasers with the chemical bonding energy of some organic radicals is shown in *Figure 9.44*. By using a short-wavelength laser, direct dissociation can be initiated.

At ultra-high laser emission intensities, plasma effects become dominant. In this region of interaction, temperatures of millions of degrees can be realised. Strong UV and X-ray radiation and the formation of multiply ionised atoms are observed.

*Laser machining*⁶ Laser machining is dominantly based on the thermal processes induced by the interaction of the laser beam with matter. The characteristic features of laser machining are non-contact, rapid scan, fine spot and high energy density. Laser machining is one of the most widely distributed technologies currently used in industry. Its uses include drilling, cutting, joining or welding, material removal for trimming, marking and scribing, surface modification by transformation hardening, shock hardening, cladding and alloying. By controlling the heating and cooling rate, the crystalline structure of a surface can be manipulated to be amorphous, polycrystalline or non-equilibrium alloy.

Neodymium: YAG lasers or CO_2 gas lasers are widely used for these applications with CW operation or repetitive pulse operation to give a high average power.

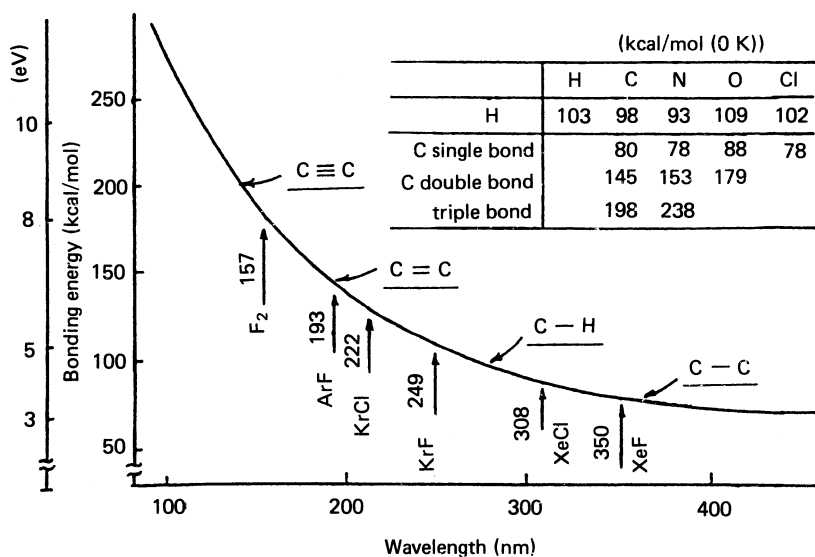

Figure 9.44 Chemical bonding energy and related wavelengths of excimer lasers

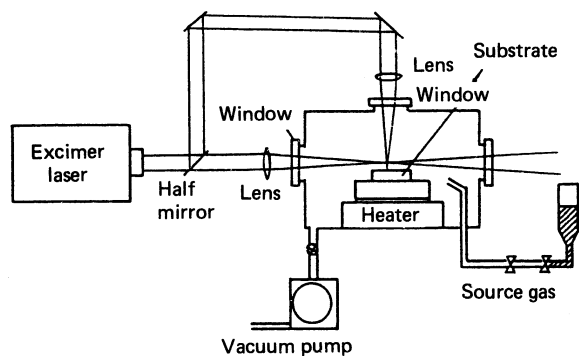

Figure 9.45 Laser CVD

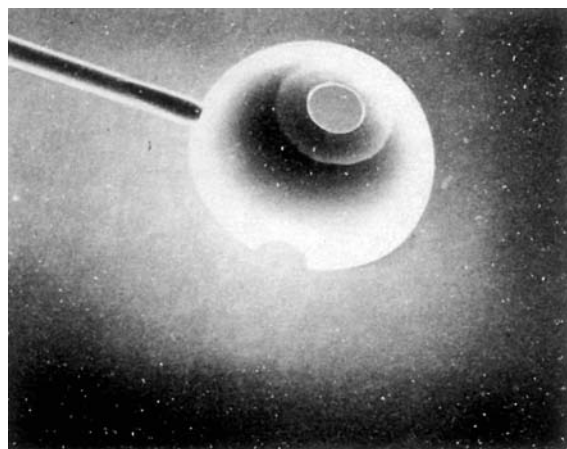

Figure 9.46 Excimer laser etching on a hemisphere of thin polyimide film

Laser photochemical processing Excimer lasers are now being used because of their short wavelengths for the initiation of photochemical processes, relying on their wavelengths being coincident with the bonding of the chemical compounds involved (Figure 9.44).

Laser chemical vapour deposition (CVD): a schematic diagram of a laser CVD system is shown in Figure 9.45. The source gas (for example Si_2H_6) is dissociated by a parallel laser beam (ArF excimer laser) and silicon is deposited on the surface of the substrate. In the case of Figure 9.45, the perpendicular beam is used to write some patterns on the substrate by the selective evaporation of the deposited thin layer.

Thin metal and dielectric layers as well as oxide may be formed by laser CVD through a combination of various source gases and laser wavelengths.

Thus laser CVD provides a means for a wide variety of processing techniques with low intrinsic damage to the substrate, and with the capability of maskless patterning.

Laser etching: laser-induced photochemical etching can be categorised into two different schemes, reactive photoetching and direct dissociative etching. Semiconductors or metals can be etched by irradiation with a laser in an atmosphere of reactive gas.

Plastics can be etched by direct dissociative etching without thermal effect by using short-wavelength lasers, the photon energy of which is higher than the bonding energy of the molecules.

Laser etching can be a low intrinsic damage process and maskless patterning is possible. Figure 9.46 shows an example of patterning by direct dissociative etching of plastics.

Lithography: the process of microlithography provides a means of microprocessing integrated circuits. Shorter wavelengths are desirable and excimer lasers are being developed as the light sources. X-ray lithography is also under development. Plasmas produced by lasers are expected to be feasible as intense X-ray sources because of a high conversion efficiency from laser to X-ray (more than

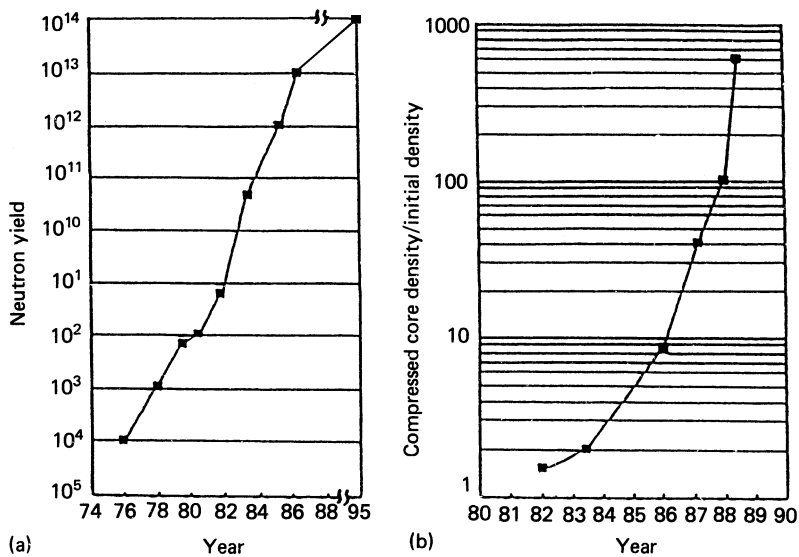

Figure 9.47 Progress towards laser fusion. (a) Neutron yield; (b) Compressed density

50%), a small point source of the order of the focal spot of the laser light, a bright source of 10^{12} – 10^{13} W/cm² steradian, soft X-rays which are suitable for lithography, and a short X-ray pulse of the order of the laser pulse width.

These features of laser produced plasma X-ray sources can also be useful for X-ray microscopy and X-ray microanalysis.

9.11.4.2 Laser fusion^{4,7}

Laser fusion is one of the most interesting applications of power lasers, where the many properties of a laser are fully utilised. The extreme concentration of energy in time and space which produces a high-density compression of fusion fuel has only become possible via laser implosion.

Focused laser beams are irradiated uniformly onto the surface of a fuel pellet and produce high-temperature plasma on the surface. The outward expansion of the plasma generates inward dynamic pressures which compress the hydrogen isotope fusion fuel. Adiabatic compression increases the density and also the temperature of the fuel and initiates the nuclear fusion. The progress which has been made towards realising laser fusion is illustrated in Figure 9.47 via the enormous increases in compressed core density and neutron yield which have been achieved. The temperature and density which have been realised are 10^8 K and 1000 times the solid hydrogen density, respectively.

Glass lasers are widely used for present laser fusion experiments.

Table 9.13 Glass laser systems world-wide

Country	Laboratory	Facility	Beam No.	Wavelength (μm)	Output (kJ)	Booster amplifier diameter (cm)	Final beam diameter (cm)
USA	LLNL	NIF (FY2008-)	192	1.05/0.35	2000/1800	Disk 40×40	38 (square)
		Nova(1986–1999)	10	1.05/0.53/0.35	125/80/55	Disk 46	74
	LLE.Rochester	Omega up-grade	60	1.05/0.35	60/30	Disk 20	20
Russia	RFNC, IEP Lebedev	Iskra-6 (proporsal)	128	1.05/0.35	500/300	Disk 20×20	20 (square)
		Delfin (-1996)	108	1.05	10	Rod 5	5
Japan	ILE.Osaka	Gekko XII	12	1.05/0.53/0.35	20/15/12	Disk 20	35
		Gekko PW (FY2000-)	1	1.05	1 (1PW)	Disk 35	35
		Gekko MII	2	1.05/0.53/0.35	2/1.5/1	Disk 20	20
France	CEA CELV Ecole Polytech.	LMJ (FY2008-)	240	1.05/0.53/0.35	2700/2000	Disk 40×40	38 (square)
		Phebus	2	1.05/0.53/0.35	20/10	Disk 46	74
		LULLI	6	1.05/0.53/0.25	0.3	Rod 8	8
UK	AWE Rutherford	Helen (proporsal)	32	1.05/0.35	200/150	Disk 40×40	38 (square)
		Vulcan	8	1.05/0.53	2.5	Disk 10	10
China	SIOFM, Shanghai Chengdu	Shen-Gang II	8	1.05/0.53	8	Disk 20	20
		Xingguang II	2	1.05/0.53/0.35	0.3/0.2	Disk 15	20
		Xingguang III (proporsal)	64	1.05/0.35	90/60	Disk 30×30	25 (square)
Italy	Frascati	ABC	1	1.05/0.53	0.1	Rod 8	10

Laser systems which are now becoming operational are listed in *Table 9.13* along with several parameters of each system.

The next stage in the research and development of laser fusion is a demonstration of ignition and energy gain. The required laser energy is estimated to be 100 kJ to megajoules of green or blue laser light with a pulse width of the order of nanoseconds.

For energy production in a commercial laser fusion reactor, repetitive operation of 1–10 Hz with a megajoule pulse energy and with 5–10% laser efficiency is required. This corresponds to the need for a megawatt short-wavelength laser with high efficiency and high focusability, which would also have a wide range of industrial applications other than laser fusion.

9.11.4.3 Other applications of high-power lasers

The fields of diagnosis and measurement are where lasers have been primarily used since the early days of their evolution. Measurements of physical quantities such as position, velocity, acceleration, direction, surface configuration, and three-dimensional configuration, utilise the coherence and directionality of laser light. Scattering measurements of Thomson (electron), Rayleigh (atom or molecule), Mie (microparticle), Raman and Brillouin provide a wide variety of methods for diagnosing physical and chemical parameters of gases, liquids, solids and plasma. Monochromaticity of laser light is widely used in these applications.

Medical applications use the thermal effect of focused laser beams. Photochemical effects are being developed for medical treatment with the progress that is being made in realising short-wavelength high-power lasers.

9.11.5 Laser pumping methods and electric power supplies

The methods of pumping a laser with their associated power supplies depend on the type of laser. They may be classified as follows.

D.c. discharge through low pressure laser gas for HeNe, HeCd, low-pressure CO₂, and ion lasers. The characteristics of the power source depend on the type and design of laser through parameters such as gas pressure, length and bore radius of the discharge tube, mixing ratio of the laser gases and the buffer or energy transfer gases. The output required from the power source may vary from milli-amperes to kiloamperes, and a few volts to kilovolts.

Pulse discharge with pre-ionisations for excimer lasers, TEA CO₂ lasers (transversely excited atmospheric pressure). To obtain a uniform discharge through the high-pressure laser gas, pre-ionisation by ultraviolet irradiation, or by surface corona discharge on the cathode is used. For the fast discharge needed for the pre-ionisation, a fast circuit with small capacitor and low stray inductance is needed in close proximity to the laser chamber. The main circuit for pumping discharge is composed of a fast capacitor bank (for the CO₂ laser), pulse forming network (PFN) with lumped capacitors and inductors or pulse forming line (PFL) with distributed transmission line. To obtain a faster rise of source power, a magnetic switch with a saturable core is used. A newly developed circuit for powering high-power excimer lasers is shown in *Figure 9.48*; this has spiker and sustainer circuits. A high repetition frequency of 1 kHz and an average output power of 2 kW can be obtained.

Electron-beam-controlled discharge for high-pressure, high-power CO₂ lasers. One of the most advanced electrical discharge concepts is electron-beam-controlled discharge. A uniform discharge through a high pressure gas up to a few tens of atmospheres and with an optimised E/p ratio for laser pumping can be achieved, where E is the electric-field strength and p is pressure. A uniform electron beam is introduced into the discharge region through a thin foil that separates the high-pressure region from a vacuum region where the electron beam gun is situated. Rectangular high voltage pulses of a few microseconds duration and a few hundred kilovolts amplitude are generated by a PFN with the capacitor elements of a Marx type generator.

Optical pumping of solid-state lasers with d.c. or pulse operation. For d.c. laser operations, a krypton arc lamp is widely used. The specifications for the power source depend

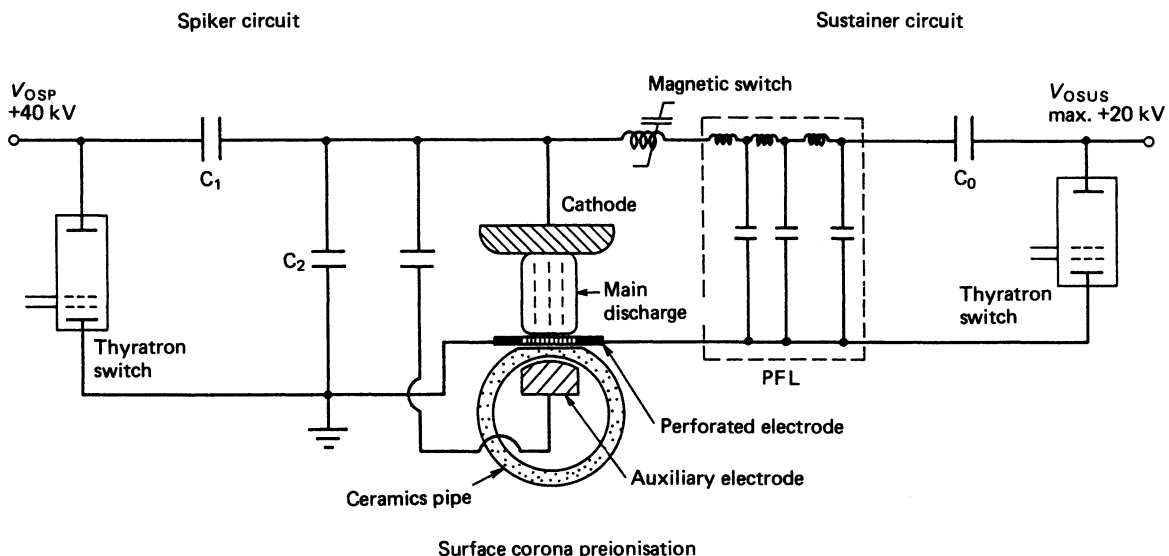

Figure 9.48 Combination of a surface corona pre-ionised discharge electrode with a spiker-sustainer pulse circuit (repetitive operation)

on the current density, bore radius, arc length, and gas pressure of the lamp. Typical discharge parameters are 100–200 V, 10–40 A, for a krypton arc lamp of 6 mm inner diameter, 150 mm arc length, with 4 atm gas pressure. A constant-current d.c. power supply with feedback stabilisation and a few kilovolts trigger circuit is used.

For pulse operations, a xenon flash lamp is widely used. The power source is usually PFN with the lamp elements, the length of current pulse is designed to match the fluorescent life-time of the laser material which is between 100 μ s and 1 ms.

Recently, LD pumping has become a feasible technology for high-efficiency, d.c. or high repetitive-pulse operation of solid-state lasers. The most important feature of LD pumping is the matching of the LD emission spectrum to the absorption of the laser materials. The specification of the power source for an LD is 2–3 V and a few amperes for one element. LDs with an output of 1–150 W (quasi-CW) are commercially available and 420 kW with 10 Hz, 100–400 μ s pulsewidth with arrayed LD has been reported. LD-pumped solid-state lasers, together with frequency conversion, will become one of the key technologies of high-power laser systems of the future.

Acknowledgements

Peter Jones would like to thank his former colleagues M. Copsey, A. Dexter, J. Driscoll, J. Griffith, I. Harvey,

P. Hayes, J. Hutchison, M. Lees, R. Perkin, D. Simpson, L. Smith and R. Townend for their contributions. Section 9.6 was based on an article originally published in *Power Engineering Journal* and subsequently in *Cast Metal Journal*.

References

- 1 *Laser Handbook*, The Laser Society of Japan (1982) (in Japanese)
- 2 BROMBERG, J. K., *Phys. Today*, **26** (October 1988)
- 3 NAKAI, S. ed. 'Power Laser Technology', Ohmsha (1999) (in Japanese)
- 4 'Energy from Inertial Fusion', International Atomic Energy Agency (IAEA), Vienna (1995)
- 5 CLEO (Conference on Lasers and Electro-Optics), is held every year and provides wide and up to date information on lasers
- 6 *Proceedings of International Conference on Laser Advanced Materials Processing—Science and Applications*, 21–23 May 1987, High Temperature Society of Japan, Osaka (1987)
- 7 NAKAI, S., 'Inertial confinement', *Nuclear Fusion*, **30**(9), 1779, 1963 (1990)